

**Epple**®

**Maschinen**

www.epple.com GERMANY

ENGLISH



Machines for Craftsmen and Industry

## Main Catalogue 2021

### Metalworking

Drilling - Milling - Turning - Sawing - Grinding - Accessories



Your reliable partner since 45 years

### Sheet Metal Forming

Bending - Folding - Cutting - Water/Plasma/Laser





## 45 years of Epple Maschinen®

Now in the second generation, with more than 35 years of experience abroad

**Epple Maschinen®** high quality metal and sheet metal working machines in an extraordinary good price-performance provides oder offers.

Since its foundation in 1976, the extensive product range consists of in-house developments and contract manufacturing by well-chosen manufacturers and joint venture companies. The high quality standards can be achieved through relationships of many years. This makes it possible to manufacture products within a price-performance ratio in a quality that our customers have trusted for over 45 years.

## Decades of experience support the continuous development

The knowledge gained from decades of experience is used to continuously develop and optimize our products. A constant exchange from the planning phase to the finished product by our technically highly qualified team is very important for us. Already during the production processes the products are inspected by our quality management. As a result, **Epple Maschinen®** offers you high quality machines at an extraordinarily good price-performance ratio.

## Development and construction

During planning and development of new **Epple Maschinen®** we proceed customer-oriented as well as innovative.

This is how we have been holding our high position on the constantly changing, developing machine tool and sheet metal working machine market for years.

In order to guarantee the product **Epple Maschinen®** application-technical tests are taken satisfaction of all products.

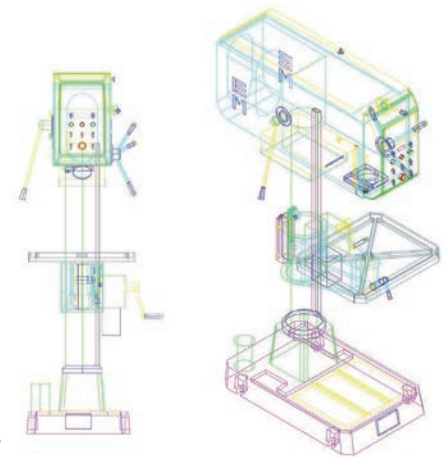

**Serial production** - view into the production hall



## Production

**Epple Maschinen**<sup>®</sup> are manufactured according to our special specifications under high quality requirements with direct influence on the production.

The quality of **Epple Maschinen**<sup>®</sup> is ensured by constant controls during production and outgoing goods, as well as continuous influence on improvement ideas and processes. We consider this an important part of quality assurance for the satisfaction of our customers.

## Quality

Due to the quality standard and the very good price-performance ratio, **Epple Maschinen**<sup>®</sup> are demanded on the market in many branches.



## Certification and technical documentation

**Epple Maschinen**<sup>®</sup> are manufactured according to the relevant standards and have a meaningful and up-to-date operating manual.



## Consulting, sales department and delivery

Consulting, sales and delivery of **Epple Maschinen**<sup>®</sup> is carried out in Germany and abroad through well-assorted retailers and regional partners.

We will be pleased to name the closest specialist retail partner for you. Our sales representatives are available for consultation to all interested clients.



## Retailers

Through our specialist dealer distribution network, you have a contact person close to you, who guarantees advice and after-sales service. Our service team is at your disposal - of course without expensive hotline numbers.

## Partners abroad

**Epple Maschinen**<sup>®</sup> has high recognition on the German and European market thanks to competence, many years of experience and the good price-performance ratio. We also work with expert partners outside Europe.

## Delivery capability

**Epple Maschinen**<sup>®</sup> has a large warehouse at the company headquarters in Wiesensteig, which enables a high delivery capacity. Orders are processed in the shortest possible time, and machines which are not produced according to special, order-related customer requirements can be delivered within a few days. An extensive spare parts warehouse ensures that products from **Epple Maschinen**<sup>®</sup> can be used for years and in some cases decades.

## Briefings and training

**Epple Maschinen**<sup>®</sup> are designed for easy handling. Nevertheless, training is recommended for some models. Therefore, you can order instruction or training on the machine functions through specialist dealers on site or at our company headquarters.

## 45 Jahre Epple Maschinen<sup>®</sup>

Since its foundation in 1976, the company culture of **Epple Maschinen<sup>®</sup>** has included offering products for different requirements at the best possible price-performance ratio. To make it easier for you to find the right machines for your application, we have divided our **Epple Maschinen<sup>®</sup>** brand into three product ranges and price categories: Standard, PREMIUM-Line and HIGHLINE.

**Epple Maschinen<sup>®</sup>** have been manufactured according to our special specifications for years under high quality requirements and direct intervention in production. There are similar products on the market which do not reach the quality standards of **Epple Maschinen<sup>®</sup>**. Many machines from the standard **Epple Maschinen<sup>®</sup>** range have therefore been copied for years. Choose the originals from **Epple Maschinen<sup>®</sup>**.

### Product line Standard\*

Machines from China/Taiwan for the price-conscious, professional craftsman and industrial operation (\* see p. 320).

### Product line PREMIUM-Line for the demanding user.

All machines of the PREMIUM-Line series are manufactured by renowned western industrial manufacturers with decades of experience for the **Epple Maschinen<sup>®</sup>** brand. The machines are characterised by a high degree of stability, user-friendliness and functionality. Features that contribute decisively to professional work results.

NEW

in the catalogue (excerpt, not complete)



GEARED BENCH DRILLING MACHINE, P. 22



RADIAL DRILLING MACHINE, P. 32



TOOL MILLING MACHINE, P. 45



BED-TYPE MILLING MACHINE, P. 56



METAL BAND SAW, P. 82



CIRCULAR SAW WITH AUTOMATIC, P. 130



CIRCULAR SAW WITH VERTICAL GUIDANCE, P. 132



FULLY AUTOMATIC CIRCLE SAW, P. 133

**NEW**

**in the catalogue (excerpt, not complete)**



BELT GRINDING MACHINE, P. 144



BELT GRINDING MACHINE, P. 144



FLAT- AND SURFACE GRINDING MACHINE, P. 149



TUBE BENDING MACHINE, P. 155



MANUAL BENDING MACHINE ROLLER SHEARS, P. 175



3-ROLLER-ROUND BENDING MACHINE, P. 188



HYDRAULIC 3-ROLLER-BENDING MACHINE, P. 191



MOTORIZED 4-ROLLER ROUND BENDING MACHINE, P. 198



HYDRAULIC PROFILE ROLLER MACHINE, P. 215



MANUAL NOTCHING MACHINE, P. 231



MOTORIC GUILLOTINE SHEARS, P. 241



PRECISION PLASMA CUTTING MACHINES, P. 248



HYDRAULIC HORIZONTAL PRESS, P. 266



VERTICAL HYDRAULIC PRESSES, P. 267



UNIVERSAL HYDRAULIC PRESS, P. 277



PRESS BRAKES, P. 280



WELDING POSITIONER, P. 286



EDGE MILLING MACHINE, P. 288



## Main catalogue

This main catalogue 2021 contains the essential data of the products of **Epple Maschinen®**. The main catalogue is also available online in several languages.

## Homepage

You can find our internet presentation at

[www.epple.com](http://www.epple.com)



## Trade fairs and exhibitions

**Epple Maschinen®** have been exhibitors at important trade fairs in Germany for many years. Outside Germany, you will find **Epple Maschinen®** at sales partners and at a number of trade fairs.

Our global presence is constantly being expanded through a network of importers, specialist dealers, trading partners and service companies.

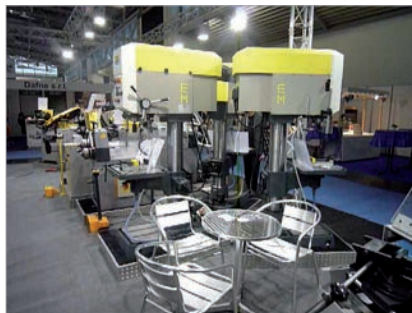

## Advertising material

*Our own advertising department, equipped with state-of-the-art equipment, offers professionally designed flyers, posters, wall calendars and advertising material etc..*



## Special sale

At our headquarters in Wiesensteig, we offer a special sale of tested, fully functional machines at reduced prices, e.g. 2nd choice machines, machines with transport damage, discontinued models, sample machines and occasionally used machines.

You can find these special sale machines at [www.epple.com/sonderverkauf.html](http://www.epple.com/sonderverkauf.html)



<b>DRILLING</b>	<b>15 - 32</b>
TB 23-230 V / TB 23-400 V	16
SBS 23 / SBS 32	17
TBH 24 / TBH 24 VARIO	18 - 19
SBH 28 / SBH 28 VARIO	18 - 19
SBH 36 / SBH 36 VARIO	19
SBH 36 NC VARIO	19
SB 55 SV / SB 55 GSV	20 - 21
TGBS 25 / TGBS 25 G	22
SBH 32 GSV	23
GB 32 / GB 33	24 - 25
GB 40 NC / GB 50 NC VARIO	26
GBH 45 / GBH 45 V	27
GB 50 V	28 - 29
GSA-P 900-12 / GSA-P 900-12 HV	30
GSA-E - MODELS	31
RB 40	32
<b>MILLING</b>	<b>33 - 56</b>
BFM 16 VARIO / BFM 20 VARIO	34 - 35
BFM 20 L VARIO / BFM 28 VARIO / BFM 35 VARIO	34 - 35
BFM 30 PG / BFM 45 PG	36 - 37
BFM 45 PG VARIO / BFM 45 PGV	36 - 37
BFM 45 PGDV DIGI	36 - 37
BFM 50 PG	38
BFM 60 DIGI	39
FM 50 S / FM 50 S DIGI	40 - 41
UFM 80 DIGI / UFM 80 L DIGI	42 - 43
WFM 80 DIGI	44
DF 2 DIGI / DF 4 DIGI	45
VFM 95 / VFM 95 DIGI	46

**MILLING**

VHFM 95 / VHFM 95 DIGI

UFM 100 DIGI

UFM 200 DIGI

UFM 260 DIGI / UFM 260 L DIGI

VFM 240 / VFM 240 DIGI

VFM 2150 SERVO

HFM 1560 / HFM 2060

HFM 2580 / HFM 3080

**TURNING**

TD 1803 VARIO / TD 2004 VARIO

TD 2406 / TD 2406 VARIO

TD 2506 / TD 2506 VARIO

TD 2807 / TD 2807 VARIO

TD 3018 / TD 3018 VARIO

TD 3209 VARIO / TD 3209 VARIO DIGI

MD 300-910 / MD 300-910 DIGI

MD 360-1.000 / MD 360-1.000 DIGI

MD 360-1.000 S DIGI

TD 4210 / TD 4210 DIGI

TD 4610 / TD 4610 DIGI

TD 4615 / TD 4615 DIGI

TD 5615 DIGI / TD 5620 DIGI / TD 5630 DIGI

TD 6615 DIGI / TD 6620 DIGI / TD 6630 DIGI

TD 8020 / TD 8030 / TD 8040

**SAWING**

BS 125 GS

BS 128 DG

BS 151 GS

BS 180 / BS 180 G

BS 210 G / GF

BS 230 V / VG

36 - 56

47

48 - 49

50 - 51

52 - 53

54

55

56

56

57 - 74

58

59

59

60

61

62

63

64 - 65

64 - 65

66 - 67

68 - 69

68 - 69

70 - 71

72 - 73

74

75 - 138

76

77

78

79

80

81





**SÄGEN**

75 - 138

	BSP 200	82
	BS 262 DG	83
	BS 275 G / GS / GF	84
	BS 280 DGS / DGF	85
	BS 300 DGH / DGHF	86
	BS 350 DG / DGH / DGHF	87
	BS 360 DGH / DGHF	88
	E-BS 230 DG / DGH / V PREMIUM-LINE	89
	E-BS 270 DG / DGH PREMIUM-LINE	90
	E-BS 320 H / V / DGH PREMIUM-LINE	91
	E-BS 320 HL / VL PREMIUM-LINE	92
	E-BS 320 GV / GVL PREMIUM-LINE	93
	E-BSP 325 GH / GV PREMIUM-LINE	94 - 95
	E-BSP 330 NC PREMIUM-LINE	96
	E-BSPC 330 NC PREMIUM-LINE	97
	E-BS 350 V PREMIUM-LINE	98
	E-BS 360 DGH ECO PREMIUM-LINE	99
	E-BS 360 DGH / E-BS 440 DGH PREMIUM-LINE	100 - 101
	E-BSP 360 GV / E-BSP 440 GV PREMIUM-LINE	102 - 103
	E-BSP 360 DGH / E-BSP 440 DGH /	104 - 105
	E-BSP 440 DG-NC PREMIUM-LINE	104 - 105
	E-BS 440 V / E-BS 460 V PREMIUM-LINE	106 - 107
	E-BSP 540 GH PREMIUM-LINE	108 - 109
	E-BSP 560 DGH PREMIUM-LINE	110 - 111
	E-BSP 570 CNC PREMIUM-LINE	112 - 113
	E-BSP 650 DGH-NC / 750 DGH-NC PREMIUM-LINE	114 - 115
	E-BSP 810 GH PREMIUM-LINE	116
	E-BSP 820 H / V PREMIUM-LINE	117
	E-BSP 1.020 H PREMIUM-LINE	118 - 119
	E-BSP 1.110 H / HL PREMIUM-LINE	120 - 121
	E-BSP 1.313 H / E-BSP 1.515 H PREMIUM-LINE	122 - 123

**SAWING**

E-BSP 2.020 H PREMIUM-LINE

**SELECTION GUIDE FOR BAND SAW BLADES**

KKS 315 L / KKS 315 SA

E-MKS 315 / E-MKS 315 P / E-MKS 315 SA NC

E-KKS-MZ 315 NC PREMIUM-LINE

E-KKS-MZ 350 V PREMIUM-LINE

E-VKKS 350 / E-VKKS 400 PREMIUM-LINE

E-KKS 350-80 V / 360-100 V PREMIUM-LINE

AKS 400

E-UAKS 400 / E-UAKS 450 / E-UAKS 550

E-AKS 2L-420 / E-AKS 2L-450 / E-AKS 2L-500

TM 350 / TM 350 PROFI

VBS 300 / VBS 400 / VBS 500 / VBS 585

**GRINDING**

DS 150 / DS 175 / DS 200-400V

ISM 250 / ISM 250 F

TBSM 100-2

BSM 75 / BSM 75-2 / BSM 75 A

BSM 150 / BSM 150-2

BSM 150 A / BSM 220

E-BTSM 50 / E-VBSM 60 / E-HBSM 75

KRBS 100

E-KRBS 100-90 / E-KRBS 100-170

E-RSM 76 / E-RSM 114 PREMIUM-LINE

E-VFSM 150

HFSM 4020 / HFSM 5025

HFSM 6030 / HFSM 8040

E-ZB BSM 2.100 PREMIUM-LINE

**METAL FORMING**

UB 40 / WB 100 / UBM

RB 10 T / RBE 10 T

75 - 138

122 - 123

124 - 127

128

129

130

131

132

133

134

135

136

137

138

139 - 150

140

141

142

142

143

143

144

145

146

147

148

149

149

150

151 - 170

152

153



**METAL FORMING 151 - 170**



HCP 30 / HCP 40 / HCP 50 NC 154

E-MRB 42/ E-MRB 60 PREMIUM-LINE 155

E-TBM 60 NC / E-TBM 76 NC PREMIUM-LINE 156



E-RDBM 32 M / H / HD PREMIUM-LINE 157

E-RDBM NC - MODELS PREMIUM-LINE 158 - 159

E-RDBM CNC - MODELS PREMIUM-LINE 160 - 161

SM 08 162

E-SM 12 PREMIUM-LINE 163



E-SM 12 MP PREMIUM-LINE 164

E-SM 25 MP PREMIUM-LINE 165

E-SM 40 MP PREMIUM-LINE 166



**ROLLER SETS FOR CRIMPING MACHINES 167**

E-FFM 12-4,0 / E-FFM 12-4,1 PREMIUM-LINE 168

E-PFM 13 PREMIUM-LINE 169

E-BKS 6 / E-BKS 8 PREMIUM-LINE 170



**FOLDING 171 - 180**

AKB 1.020-2,5 / AKB 1.270-2,0 172

AKB 1.020-2,5 G 173



AKB 2.020-2,0 174

E-AKB-S 1.220-0,8 / E-AKB-S 2.040-0,8 PREMIUM-LINE 175

E-AKB-S 2.540-0,8 / E-AKB-S 3.040-0,8 PREMIUM-LINE 175



AKB 2.020-1,5 E / AKB 2.020-1,5 ES 176 - 177

AKB 2.520-1,0 E / AKB 2.520-1,0 ES 176 - 177

AKB 3.020-1,0 E / AKB 3.020-1,0 ES 176 - 177

E-AKB-H 1.260-2,0 PREMIUM-LINE 178



E-AKB 1.020-4,5 HS / E-AKB 1.520-3,5 HS / 179

E-AKB 2.520-2,5 HS PREMIUM-LINE 179

MAKB 1.250-1,6 / MAKB 2.500-1,6 180

MAKB 3.200-1,2 180



**ROUND BENDING MACHINES**

RM 1.020-1,5 / RME 1.020-1,5

RME 1.300-1,5

E-RB 1.050-2,0 / E-RB 1.270-1,5 PREMIUM-LINE

E-RB 1.550-1,2 / E-RB 2.050-1,0 PREMIUM-LINE

E-RME 1.050-2,0 / E-RME 1.270-1,5 PREMIUM-LINE

E-RME 1.550-1,2 / E-RME 2.050-1,0 PREMIUM-LINE

E-RBE 1.050-3,0 / E-RBE 1.270-2,5 PREMIUM-LINE

E-RBE 1.550-2,0 / E-RBE 2.050-1,5 PREMIUM-LINE

E-RBE-H 1.270-2,5 / E-RBE-H 1.550-2,0 PREMIUM-LINE

E-RBE-H 2.050-1,5 PREMIUM-LINE

E-RWE 1.270-3,0 / E-RWE 1.550-2,5 PREMIUM-LINE

E-RWE 2.050-1,8 / E-RWE 2.550-1,0 PREMIUM-LINE

E-RBM 1.270-4,0 / E-RBM 1.550-4,0 PREMIUM-LINE

E-RBM 2.050-3,0 PREMIUM-LINE

E-RBM-S PRO - MODELS PREMIUM-LINE

E-3RBM PRO UHS - MODELS PREMIUM-LINE

E-RBM-H PRO - MODELS PREMIUM-LINE

E-3RBM PRO HS - MODELS PREMIUM-LINE

E-3RBM PRO HSS - MODELS PREMIUM-LINE

E-4RBM HS LINEAR - MODELS PREMIUM-LINE

E-4RBM 1.050-5,0 / E-4RBM 1.550-4,0 PREMIUM-LINE

E-4RBM 2.050-3,0 PREMIUM-LINE

E-4RBM-H NC - MODELS PREMIUM-LINE

E-4RBM PRO HMS - MODELS PREMIUM-LINE

E-4RBM PRO HS - MODELS PREMIUM-LINE

E-4KRB-H 1.050-3,0 / E-4KRB-H 1.050-4,0

E-4RBM PRO HSS - MODELS PREMIUM-LINE

PW 10 M / PW 30 / PW 30 HV

PW 40 HV / PW 50

ROLLER SETS PW 10 / 30 / 30 HV / 40 HV / 50

181 - 228

182

183

184

184

185

185

186

186

187

187

188

188

189

189

190

191

192 - 193

194 - 195

196 - 197

198 - 199

200

200

201

202 - 205

206

207

208 - 209

210

211

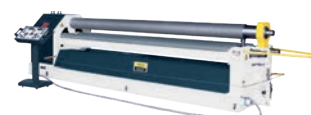

212 - 213







<b>ROUND BENDING MACHINES</b>	<b>181 - 228</b>
E-PW 31 F / E-PW 35 F	214
E-PW 40 H / E-PW 50 H / E-PW 60 H	215
E-PW 70 H	216
E-PW 65 H / E-PW 80 H	217
E-PW 100 H / E-PW 120 H	218
E-PW 160 H / E-PW 180 H	219
E-PW 200 H	220
E-PW 240 H / E-PW 360 H	221
<b>ROLLER SETS FOR E-PW - MODELS</b>	<b>222 - 225</b>
E-4PW 70 H	226
E-4PW 90 H / E-4PW 110 H	227
<b>ROLLER SETS FOR E-4PW - MODELS</b>	<b>228</b>
<b>CUTTING</b>	<b>229 - 262</b>
EK 1 / EK 2 / EK 3 / EK 8-E	230
AM 4T / AM 4T-3,0 / AM 4PT / HAM-P 3,0	231
E-HAM 4 F / E-HAM 6 VP	232
E-KS 1,8 M PREMIUM-LINE	233
E-KS 3,5 / E-KS 5 M PREMIUM-LINE	234
HS 125 / HS 150 / HS 300	235
TFS 1.050-1,0	236
E-TFS 1.050-1,5 / E-TFS 1.350-1,5 PREMIUM-LINE	237
<b>E-MTSK - MODELS PREMIUM-LINE</b>	<b>238 - 239</b>
<b>E-MTBS - MODELS PREMIUM-LINE</b>	<b>240 - 241</b>
<b>E-HTBS - MODELS PREMIUM-LINE</b>	<b>242</b>
<b>E-HSTS - MODELS PREMIUM-LINE</b>	<b>243</b>
<b>E-HTS CNC - MODELS PREMIUM-LINE</b>	<b>244 - 245</b>
<b>E-WSA - MODELS PREMIUM-LINE</b>	<b>246 - 247</b>
<b>E-PPSM - MODELS PREMIUM-LINE</b>	<b>248 - 249</b>
<b>E-IPSM - MODELS PREMIUM-LINE</b>	<b>250 - 251</b>
<b>E-LSA - MODELS PREMIUM-LINE</b>	<b>252 - 253</b>





**SCHNEIDEN**

E-HPS 40 PREMIUM-LINE	229 - 262	
E-HPS 45 / E-HPS 60 PREMIUM-LINE	254	
E-HPS 55 / E-HPS 65 PREMIUM-LINE	255	
E-HPS 65 V PREMIUM-LINE	256	
E-HPS 85 / E-HPS 115 / E-HPS 175 PREMIUM-LINE	257	

Technical Data E-HPS - MODELS	258	
-------------------------------	-----	--

E-HLS 30 / E- HLS 65 / E-HLS 85 PREMIUM-LINE	259	
E-HLS 115 / E-HLS 175 PREMIUM-LINE	260	
E-HLS DP - MODELS PREMIUM-LINE	260	
DDP 2 / DDP 3 / DDP 5	261	

**PRESS BRAKES HORIZONATAL AND VERTICAL** 263 - 284

E-HBP 10 PREMIUM-LINE	264	
E-HBP 22 / E-HBP 40 PREMIUM-LINE	265	
E-HBP 80 / E-HBP 100 PREMIUM-LINE	266	
HWP 16 / HWP-E 25	267	
HWP 30 T / HWP E 30 T PREMIUM-LINE	268	

E-HWP - MODELS PREMIUM-LINE	269 - 271	
-----------------------------	-----------	--

E-WP - MODELS PREMIUM-LINE	272 - 273	
----------------------------	-----------	--

E-WPK - MODELS PREMIUM-LINE	274	
-----------------------------	-----	--

E-WPR - MODELS PREMIUM-LINE	275	
-----------------------------	-----	---------------------------------------------------------------------------------------

E-UWP - MODELS PREMIUM-LINE	276	
-----------------------------	-----	--

E-VP - MODELS PREMIUM-LINE	277	
----------------------------	-----	---------------------------------------------------------------------------------------

HAKP 24 / HAKP 48	278	
-------------------	-----	--

E-AP - MODELS PREMIUM-LINE	279	
----------------------------	-----	--

E-GSP - MODELS	280	
----------------	-----	---------------------------------------------------------------------------------------

E-GBP-MODELS PREMIUM-LINE	281	
---------------------------	-----	--

E-GBP - MODELS	282 - 284	
----------------	-----------	--

**MOBILE AND STATIONARY DEVICES** 285 - 288

TO FACILITATE WELDING WORK

<b>ACCESSORIES</b>	289 - 315	
--------------------	-----------	---------------------------------------------------------------------------------------





# Drilling

## TB 23-230 V / TB 23-400 V

BENCH DRILL MT 2 UP TO 23 MM



PIC: TB 23-400 V

### TB 23-230 V / TB 23-400 V / SBS 23-230 V / SBS 23-400 V / SBS 32







- » solid construction suitable for craftsmen users
- » precision of concentricity < 0,02 mm measured in the spindle sleeve
- » belt housing in steel, locked cover with safety shutdown
- » powerful, smooth running electric motor, aluminum body with cooling fins
- » 400 V model with forward and reverse run
- » safety switch with low-voltage release and emergency stop
- » rotating, tilting and inclinable massive working table with T-slots for 16 mm sliding blocks
- » comfortable mechanical height adjustment of drilling table by toothed rack
- » solid, large dimensioned base plate with T-slots, precise surface finishing
- » LED working light
- » quick-action drill chuck supplied 1-16 mm
- » drill chuck guard
- » drill depth stop

- geared bench drills on page 22
- more bench drills on page 18

Description	TB 23
drilling performance	23 mm
sleeve travel	80 mm
spindle taper	MT 2
spindle speed	120 - 2.580 min <sup>-1</sup>
no. of speeds	12
automatic drilling feed	no
working range	180 mm
table size	290 x 290 mm
T-slot size (table)	16 mm
T-slot number (table)	2 (diagonal)
drilling table swivel	±45°
column diameter	80 mm
motor power	0,55 kW
dimensions (W x D x H)	300 x 500 x 980 mm
weight	56 kg
<b>Type</b>	<b>230 V</b>
<b>EAN</b>	<b>4260364290011</b>
<b>Item no.</b>	<b>210 0023</b>

<b>Type</b>	<b>400 V</b>
<b>EAN</b>	<b>4260364290028</b>
<b>Item no.</b>	<b>210 0123</b>

### Optional Accessories

Description	Item no.
 Quick Action Drill Chuck 1-16 mm	510 0016
 Morse Taper	-
 Reducing Sleeves	-
 HSS Drill Bit Set	510 9013
 MSE 75	121 0075
 Stand Universal	535 1035

You can find detailed accessories on page 289.

# SBS 23-230 V / SBS 23-400 V SBS 32

COLUMN DRILLING MACHINES MT 2 UP TO 23 MM



PIC: SBS 23-230 V



PIC: SBS 32

Description	SBS 23	SBS 23	SBS 32
drilling performance	23 mm	23 mm	32 mm
sleeve travel	80 mm	80 mm	120 mm
spindle taper	MT 2	MT 2	MT 4
spindle speed	120 - 2.580 min <sup>-1</sup>	120 - 2.580 min <sup>-1</sup>	150 - 2.700 min <sup>-1</sup>
no. of speeds	12	12	12
automatic drilling feed	no	no	no
working range	180 mm	180 mm	255 mm
table size	290 x 290 mm	290 x 290 mm	475 x 425 mm
T-slot size (table)	16 mm	16 mm	18 mm
T-slot number (table)	2 (diagonal)	2 (diagonal)	3
drilling table swivel	±45°	±45°	±45°
column diameter	80 mm	80 mm	90 mm
motor power	0,55 kW	0,55 kW	1,1 kW
dimensions (W x D x H)	310 x 550 x 1.480 mm	310 x 550 x 1.480 mm	500 x 700 x 1.750 mm
weight	65 kg	65 kg	137 kg
	<b>230 V</b>	<b>400 V</b>	<b>400 V</b>
<b>EAN</b>	<b>4260364290059</b>	<b>4260364290066</b>	<b>4260364290073</b>
<b>Item no.</b>	<b>215 0023</b>	<b>215 0123</b>	<b>210 0132</b>

TBH 24 / TBH 24 VARIO / SBH 28  
SBH 28 VARIO / SBH 36 / SBH 36 VARIO  
SBH 36 NC VARIO

BENCH AND COLUMN DRILLING MACHINES



PIC: TBH 24 VARIO



PIC: SBH 28



PIC: SBH 36 VARIO

Technical Data SBH 28 Vario / SBH 36 / SBH 36 Vario / SBH 36 NC Vario on page 19.

Description	TBH 24	TBH 24 Vario	SBH 28
drilling cap in steel	24 mm	24 mm	28 mm
sleeve travel	85 mm	85 mm	105 mm
spindle taper	MT 2	MT 2	MT 3
spindle speeds	360 - 4.200 min <sup>-1</sup>	100 - 4.400 min <sup>-1</sup>	120 - 4.250 min <sup>-1</sup>
no. of speeds (over wedge straps)	7	4	16
automatic drilling feed	no	no	no
working range	165 mm	165 mm	200 mm
table size	280 x 300 mm	280 x 300 mm	340 x 360 mm
T-slot size (table)	14 mm	14 mm	14 mm
T-slot number (table)	2 (diagonal)	2 (diagonal)	2 (diagonal)
column diameter	80 mm	80 mm	92 mm
distance spindle to table max.	515 mm	495 mm	858 mm
distance spindle to foot max.	681 mm	681 mm	1.270 mm
motor power	400 V / 50 Hz / 0,75 kW	230 V / 50 Hz / 1,5 kW	400 V / 50 Hz / 0,85 kW
dimensions (W x D x H)	515 x 740 x 1.170 mm	515 x 740 x 1.170 mm	575 x 840 x 1.750 mm
weight	150 kg	120 kg	200 kg
	<b>TBH 24</b>	<b>TBH 24 Vario</b>	<b>SBH 28</b>
<b>EAN</b>	<b>4260364290035</b>	<b>4260364290042</b>	<b>4260364290080</b>
<b>Item No.</b>	<b>210 6024</b>	<b>210 6124</b>	<b>215 6028</b>

**TBH 24 / TBH 24 VARIO**  
**SBH 28 / SBH 28 VARIO**  
**SBH 36 / SBH 36 VARIO**  
**SBH 36 NC VARIO**  
BENCH AND COLUMN DRILLING MACHINES

- » Bench drill and drill press in raised execution for handcraft and industrial use
- » running accuracy measured < 0,02 mm in the drilling barrel
- » belt cover out of metal with safety shutdown
- » high-grade two step aluminium electric motor with cooling fins aluminium electric motor with cooling fins - model Vario with continuously rotation speed control via frequency converter
- » digital LED-rotation speed display (model Vario)
- » high turning movement
- » switch for clockwise/anticlockwise rotation
- » SBH 36 Vario with operating type reaming/auto
- » precise surface processing, massive and stable work table, pivotable, slewable, inclinable with T-slots with 14 mm sliding blocks
- » comfortable mechanical height adjustment for the table via rack
- » large and massive base plate with T-slots, precise surface processing
- » integrated establishment for coolant with coolant tank  
(only model SBH 28 Vario and SBH 36 Vario)
- » LED working light
- » **model TBH 24 and TBH 24 Vario:** with quick-release chuck supplied as standard 1-16 mm
- » **model SBH 28 and 36:** with quick-release chuck supplied 1-16 mm as standard
- » digital drilling depth display (only model SBH 36)



PIC: DISPLAY COVER

**TOUCH-SCREEN-BEDIENUNG**  
**ENGINEERED AND DESIGNED**  
**BY EPPLE MASCHINEN®**

Description	SBH 28 Vario	SBH 36	SBH 36 Vario	SBH 36 NC Vario
drilling cap in steel	28 mm	34 mm	34 mm	34 mm
sleeve travel	105 mm	160 mm	160 mm	160 mm
spindle taper	MT 3	MT 4	MT 4	MT 4
spindle speeds	35 - 6.100 min <sup>-1</sup>	130 - 4.940 min <sup>-1</sup>	40 - 6.500 min <sup>-1</sup>	40 - 6.500 min <sup>-1</sup>
no. of speeds (via V-belts adjust)	12	9	9	9
speed via potentiometer	stepless	no	stepless	stepless
automatic drilling feed	no	no	no	no
working range	200 mm	285 mm	285 mm	285 mm
table size	340 x 360 mm	420 x 400 mm	400 x 500 mm	400 x 500 mm
T-slot size (table)	14 mm	14 mm	14 mm	14 mm
T-slot number (table)	2 (diagonal)	2 (diagonal)	2 (diagonal)	2 (diagonal)
column diameter	92 mm	115 mm	115 mm	115 mm
distance spindle to table	max. 765 mm	max. 790 mm	max. 790 mm	max. 790 mm
distance spindle to foot max.	1.200 mm	1.270 mm	1.270 mm	1.270 mm
motor power	230 V / 50 Hz / 1,5 kW	400 V / 1,5 kW 2,2 kW	230 V / 2,2 kW	230 V / 2,2 kW
dimensions (W x D x H)	575 x 840 x 1.750 mm	560 x 910 x 1.935 mm	560 x 910 x 1.935 mm	560 x 910 x 1.935 mm
weight	200 kg	360 kg	360 kg	360 kg
	<b>SBH 28 Vario</b>	<b>SBH 36</b>	<b>SBH 36 Vario</b>	<b>SBH 36 NC Vario</b>
<b>EAN</b>	<b>4260364290097</b>	<b>4260364290103</b>	<b>4260364290110</b>	<b>4260364295689</b>
<b>Item No.</b>	<b>215 6128</b>	<b>215 6036</b>	<b>215 6136</b>	<b>215 6236</b>



PIC: SBH 36 NC VARIO WITH DISPLAY

DRILLING

MILLING

TURNING

SAWING

GRINDING

BENDING

CUTTING / PRESSING

OTHER MACHINES

ACCESSORIES



**SB 55 SV / SB 55 GSV**  
COLUMN DRILLING MACHINE



PIC: SB 55 SV



**SB 55 GSV**  
» with thread cutting device

Description	SB 55 SV
drilling cap in steel	50 mm
sleeve travel	160 mm
spindle taper	MT 4
spindle speeds	85 - 1.900 min <sup>-1</sup>
speeds	stepless
automatic drilling feed	0,10-0,20-0,30 mm/rev
working range	320 mm
table size	500 x 425 mm
T-slot size (table)	14 mm
T-slot number (table)	2 (diagonal)
drilling table swivel	±45°
column diameter	110 mm
distance spindle to table max.	590 mm
distance spindle to foot max.	1.140 mm
motor power	400 V / 1,0 kW / 1,7 kW
dimensions (W x D x H)	515 x 965 x 1.920 mm
weight	450 kg
	<b>SB 55 SV</b>
<b>EAN</b>	<b>4260364290158</b>
<b>Item No.</b>	<b>210 2055</b>

	SB 55 GSV
<b>EAN</b>	<b>4260364294187</b>
<b>Item No.</b>	<b>210 2155</b>



# TGBS 25 / TGBS 25 G

## GEARED BENCH DRILLING MACHINES

**NEW**



PIC: TGBS 25

### TGBS 25 / TGBS 25 G

- » sturdy geared bench drilling machine
- » stable, rotating and swivelling worktable
- » automatic gear lubrication
- » thread cutting device (only TGBS 25 G)
- » adjustable drilling depth stop with millimetre scale
- » height-adjustable protective screen with microswitch
- » strong base plate, precisely surface machined
- » LED working light
- » quick-action drill chuck as standard 1-16 mm

**The TGBS 25 and TGBS 25 G are suitable for flow drilling - flow drilling see at page 299**

Description	TGBS 25	TGBS 25 G
drilling performance	25 mm	25 mm
sleeve travel	130 mm	130 mm
spindle taper	MT 3	MT 3
spindle speed	75 - 3.200 min <sup>-1</sup>	75 - 3.200 min <sup>-1</sup>
no. of speeds	12	12
automatic drilling feed	-	-
working range	250 mm	250 mm
table size	380 x 380 mm	380 x 380 mm
T-slot size (table)	14 mm	14 mm
T-slot number (table)	2	2
column diameter	100 mm	100 mm
distance spindle to table	360 mm	360 mm
distance spindle to foot	620 mm	620 mm
motor power	0,85 kW / 1,1 kW	0,85 kW / 1,1 kW
dimensions (W x D x H)	660 x 400 x 1.300 mm	660 x 400 x 1.300 mm
weight	220 kg	220 kg
	<b>TGBS 25</b>	<b>TGBS 25 G</b>
<b>EAN</b>	<b>4260657650201</b>	<b>4260657650232</b>
<b>Item no.</b>	<b>215 1125</b>	<b>215 1225</b>

# SBH 32 GSV

## GEARED HEAD DRILLING MACHINES

NEW

Machine available in summer 2021.









### SBH 32 GSV

- » heavy, solid cast iron design
- » frequency converter
- » digital speed display
- » thread cutting device
- » high concentricity due to hardened and ground main spindle
- » low maintenance gear with grease lubrication
- » gear with PA6 gears
- » wide speed range
- » adjustable drilling depth stop with millimeter scale
- » height-adjustable protective disk with microswitch against flying chips for maximum protection
- » user-friendly foil keyboard
- » right-/left-handed rotation
- » integrated ejector for easy tool change
- » precisely machined drilling table with diagonally running T-slots and circulating cooling water trough
- » thick-walled cast column for high force absorption and stability
- » LED working light
- » solid base plate, large dimensioned and heavily ribbed on the back

The SBH 32 GSV is suitable for flow drilling - Flow drilling see on page 299

Description	SBH 32 GSV
drilling performance	30 mm
sleeve travel	125 mm
spindle taper	MT 4
spindle speed	50 - 3.000 min <sup>-1</sup>
no. of speeds	4
automatic drilling feed	0,05 / 0,1 mm/rev
working range	285 mm
table size	400 x 420 mm
T-slot size (table)	14 mm
T-slot number (table)	2
column diameter	115 mm
distance spindle to table	820 mm
distance spindle to foot	1.270 mm
motor power	400 V / 2,2 kW
dimensions (W x D x H)	450 x 760 x 2.230 mm
weight	335 kg
	<b>GB 30</b>
<b>EAN</b>	<b>4260657650737</b>
<b>Item no.</b>	<b>215 1130</b>

### Optional Accessories

Description	Item no.
 Morse Taper	-
 Extension Sleeves	-
 HSS Drill Bit Set	510 9013
 Morse Taper Drill Case 1	510 1423
 Morse Taper Drill Case 2	510 1430
 Flow punch drilling Starter set M10	511 0001
 Coolant emulsion 5 litres	580 1030
 Transmission oil AR 150	580 1150
Foot switch for switching between clockwise and counterclockwise rotation and for thread cutting	

You can find detailed accessories on page 289.

DRILLING

MILLING

TURNING

SAWING

GRINDING

BENDING

CUTTING / PRESSING

OTHER MACHINES

ACCESSORIES

## GB 32 / GB 33

### GEARED HEAD DRILLING MACHINES



PIC: GB 32  
automatic mechanical feed



PIC: GB 33  
electrical feed



















Description	GB 32	GB 33
drilling cap in steel	35 mm	35 mm
sleeve travel	180 mm	180 mm
spindle taper	MT 4	MT 4
spindle speeds	50 - 1.450 min <sup>-1</sup>	50 - 1.450 min <sup>-1</sup>
no. of speeds	18	18
automatic drilling feed	0,10 and 0,20 mm/rev	0,10 and 0,20 mm/rev
working range	350 mm	350 mm
table size	550 x 550 mm	550 x 550 mm
T-slot size (table)	16 mm	16 mm
T-slot number (table)	2 (diagonal)	2 (diagonal)
column diameter	150 mm	150 mm
distance spindle to table max.	700 mm	700 mm
distance spindle to foot max.	1.200 mm	1.200 mm
motor power	400 V / 0,85 kW / 1,5 kW	400 V / 0,85 kW / 1,5 kW
dimensions (W x D x H)	650 x 900 x 2.250 mm	650 x 900 x 2.250 mm
weight	450 kg	470 kg
	<b>GB 32</b>	<b>GB 33</b>
<b>EAN</b>	4260364290196	4260364290202
<b>Item No.</b>	215 1132	215 1133



### GB 32 / GB 33

- » heavy construction
- » lockable main switch and motor protection switch
- » 18 speeds shiftable by gear levers and 2-step driving motor
- » mechanical spindle feed with 2 speeds
- » automatic gear wheel lubrication
- » spindle locking with integrated drill ejection for easy tool change
- » height adjustable protective screen with micro switch providing for best protection
- » high concentricity precision due to hardened and ground main spindle
- » large dimensioned, thick walled cast column for smooth running
- » large working range
- » massive tilting, rotating and inclinable work table (GB 33) with T-slots for 16 mm sliding blocks, precise surface finishing
- » large and massive base plate with T-slots, precise surface finishing
- » integrated coolant system and coolant tank
- » adjustable drill depth stop with millimeter scale on the front panel
- » LED working light
- » quick-action drill chuck as standard 1 - 16 mm
- » **thread cutting device (up to M32)**

## Optional Accessories

Description	Item-No.	Description	Item-No.
 Quick Action Drill Chuck RÖHM 1-13 mm	510 3013	 MS 125	120 0125
 Quick Action Drill Chuck RÖHM 3-16 mm	510 3016	 UPS 100	520 4010
 HSS Drill Bit Set	510 9013	 Morse Taper Drill Case 1	510 1423
 MSE 75	121 0075	 Morse Taper Drill Case 2	510 1430
 MSE 100	121 0100	 Morse Taper	-
 MSE 125	121 0125	 Reducing Sleeves	-
 MSE 150	121 0150	 Extension Sleeves	-
 MSI 100	121 2100		
 MSI 140	121 2140		
 MSI 200	121 2200		
 MS 100	120 0100		

You can find detailed accessories on page 289.

## GB 40 NC / GB 50 NC VARIO

### GEARED HEAD DRILLING MACHINES

**NEW**



PIC: GB 50 NC VARIO

PIC: GB 40 NC

#### GB 40 NC / GB 50 NC Vario

- » sturdy geared head drilling machines with large dimensioned, thick-walled column
- » hardened and ground main spindle
- » automatic gear lubrication
- » thread cutting device
- » automatic feed by electromagnetic clutch
- » adjustable drill depth stop with millimeter scale on the front panel
- » height-adjustable protective screen with microswitch
- » precise surface-treated, massive and stable work table, rotatable and pivotable
- » large and massive base plate, precise surface finishing
- » integrated coolant system and coolant tank
- » LED working light
- » quick-action drill chuck as standard 1 - 16 mm

Description	GB 40 NC	GB 50 NC Vario
drilling performance	40 mm	50 mm
sleeve travel	200 mm	200 mm
spindle taper	MT 4	MT 4
spindle speed	52 - 1.400 min <sup>-1</sup>	50 - 2.200 min <sup>-1</sup>
no. of speeds	12	stepless
automatic drilling feed	0,1 - 0,4 mm/rev	0,08 - 0,5 mm/rev
working range	360 mm	360 mm
table size	580 x 460 mm	580 x 460 mm
T-slot size (table)	14 mm	14 mm
T-slot number (table)	2 (diagonal)	2 (diagonal)
column diameter	160 mm	180 mm
distance spindle to table	415 mm (manual 590 mm)	550 mm (manual 565 mm)
distance spindle to foot	1.175 mm	1.165 mm
motor power	2,2 kW	3,0 kW
dimensions (W x D x H)	680 x 940 x 2.405 mm	680 x 970 x 2.340 mm
weight	650 kg	642 kg
	<b>GB 40 NC</b>	<b>GB 50 NC Vario</b>
<b>EAN</b>	<b>4260657650171</b>	<b>4260657650317</b>
<b>Item no.</b>	<b>215 2240</b>	<b>215 2250</b>

# GBH 45 / GBH 45 V

## GEARED HEAD DRILLING MACHINES

**NEW**

**Machine available in  
summer 2021**

### GBH 45 / GBH 45 V

Heavy gear head drilling machine for lasting performance.

- » heavy-duty design with stable, thick-walled column of machined cast iron
- » lockable main switch and motor protection switch
- » 18 speeds shiftable by gear levers and 2-step driving motor
- » thread cutting device
- » 3-step spindle sleeve feed, mechanically switchable (GBH 45)
- » 3-step spindle sleeve feed, switchable at turnstile (GBH 45 V)
- » automatic gear lubrication
- » spindle locking with integrated drill ejection for easy tool change
- » height adjustable protective screen with micro switch providing for best protection
- » high concentricity precision due to hardened and ground main spindle
- » large dimensioned, thick walled cast column
- » large overhang
- » massive tilting, rotating and inclinable work table  
motor-driven height adjustable, can be tilted 90° to the side,  
with T-slots for 16 mm sliding blocks, heavily ribbed underside
- » large and massive base plate with T-slots, precise surface finishing
- » integrated coolant system and coolant tank
- » adjustable drill depth stop with millimeter scale on the front panel
- » LED working light
- » quick-action drill chuck as standard 1 - 16 mm

Description	GBH 45	GBH 45 V
drilling performance	40 mm	40 mm
sleeve travel	170 mm	170 mm
spindle taper	MK 4	MK 4
spindle speed	90 - 1.520 min <sup>-1</sup>	90 - 1.520 min <sup>-1</sup>
no. of speeds	8	8
automatic drilling feed	3 steps: 0,1 / 0,15 / 0,2 mm/rev	3 steps: 0,1 / 0,15 / 0,2 mm/rev
working range	350 mm	350 mm
table size	530 x 530 mm	530 x 530 mm
T-slot size (table)	18 mm	18 mm
T-slot number (table)	2	2
column diameter	150 mm	150 mm
distance spindle to table	725 mm	725 mm
distance spindle to foot	130 mm	130 mm
motor power	2,2 kW	2,2 kW
dimensions (W x D x H)	595 x 920 x 2.380 mm	595 x 920 x 2.380 mm
weight	630 kg	630 kg
	<b>GBH 45</b>	<b>GBH 45 V</b>
<b>EAN</b>	<b>4260657650744</b>	<b>4260657650751</b>
<b>Item no.</b>	<b>215 1140</b>	<b>215 1240</b>

### OPTIONAL ACCESSORIES

Foot switch for switching between  
right and left rotation  
and for thread cutting

DRILLING

MILLING

TURNING

SAWING

GRINDING

BENDING

CUTTING /  
PRESSING

OTHER  
MACHINES

ACCESSORIES

## GB 50 V

### GEARED HEAD DRILLING MACHINE





















Description	GB 50 V
drilling cap in steel	50 mm
thread cutting performance	M42
sleeve travel	240 mm
spindle taper	MT 4
spindle speeds	40 - 2.100 min <sup>-1</sup>
no. of speeds	12
automatic drilling feed	0,10 - 0,40 mm/rev
working range	370 mm
table size	600 x 500 mm
T-slot size (table)	14 mm
T-slot number (table)	2 (diagonal)
column diameter	200 mm
distance spindle to table max.	100 - 560 mm
distance spindle to foot max.	1.180 mm
motor power	400 V / 2,2 kW / 2,8 kW
dimension (W x D x H)	680 x 950 x 2.400 mm
weight	890 kg
	<b>GB 50 V</b>
<b>EAN</b>	<b>4260364290219</b>
<b>Item No.</b>	<b>215 1250</b>

## GB 50 V

- » heavy construction
- » lockable main switch and motor protection switch
- » 12 speeds shiftable by gear levers
- » **threading attachment**
- » automatic gear wheel lubrication
- » spindle locking with integrated drill ejection for easy tool change
- » **automatic feed by electromagnetic coupling with 4 feed speeds**
- » height adjustable safety screen with micro switch providing best protection
- » high concentricity precision due to hardened and ground main spindle
- » large dimensioned, thick walled cast column for smooth running
- » large working range
- » massive tilting, rotating and inclinable work table with T-slots for 16 mm sliding blocks, precise surface finishing
- » large and massive base plate with T-slots, precise surface finishing
- » integrated coolant system and coolant tank
- » adjustable drill depth stop with millimeter scale on the front panel
- » LED working light
- » quick-action drill chuck supplied as standard 1-16 mm

The GB 50 V is suitable for flow drilling - flow drilling see on page 299

## Optional Accessories

Description	Item-No.	Description	Item-No.
 Quick Action Drill Chuck RÖHM 1-13 mm	510 3013	 MS 125	120 0125
 Quick Action Drill Chuck RÖHM 3-16 mm	510 3016	 UPS 100	520 4010
 HSS Drill Bit Set	510 9013	 Morse Taper Drill Case 1	510 1423
 MSE 75	121 0075	 Morse Taper Drill Case 2	510 1430
 MSE 100	121 0100	 Morse Taper	-
 MSE 125	121 0125	 Reducing Sleeves	-
 MSE 150	121 0150	 Extension Sleeves	-
 MSI 100	121 2100	You can find detailed accessories on page 289.	
 MSI 140	121 2140		
 MSI 200	121 2200		
 MS 100	120 0100		



## GSA-P 900-12 / GSA-P 900-12 HV THREADING MACHINES



PIC: GSA-P 900-12  
WITH OPTIONAL  
CLAMPING TABLE

### GSA-P 900-12 / GSA-P 900-12 HV

Pneumatically driven thread cutting machine for internal threads for thread cutting in through or blind holes from M3 to M12.

The Threads are cut quickly and precisely by the movable articulated arm. They are always exactly vertically and parallel to each other.

For HV versions, the cutting head can be brought into a horizontal position by 90°.

The advantages are low weight, flexibility, speed and the favourable purchase price.

The speed depends on the existing air pressure.

Scope of delivery:

- » flexible articulated arm
- » mounting flange for table or workbench
- » air pressure motor
- » quick change chuck

Description	clamping table small	clamping table large
clamping area	800 x 500 mm	900 x 600 mm
for	GSA-P 900-12 GSA-P 900-12 HV GSA-E 1.000-16 GSA-E 1.000-16 HV	GSA-E 1.200-24 GSA-E 1.200-24 HV
	clamping table small	clamping table large
<b>EAN</b>	<b>4260364297867</b>	<b>4260364297874</b>
<b>Item no.</b>	<b>520 8050</b>	<b>520 9060</b>

Description	GSA-P 900-12	GSA-P 900-12 HV
cutting capacity	M3 - M12	M3 - M12
cutting direction	vertical	vertical and horizontal
speeds	max. 400 min <sup>-1</sup>	max. 400 min <sup>-1</sup>
boom radius	max. 900 mm	max. 900 mm
drive	pneumatic	pneumatic
weight	20 kg	21 kg
	<b>GSA-P 900-12</b>	<b>GSA-P 900-12 HV</b>
<b>EAN</b>	<b>4260364297713</b>	<b>4260364297737</b>
<b>Item no.</b>	<b>215 0012</b>	<b>215 0112</b>

# GSA-E 1.000-16 / GSA-E 1.000-16 HV GSA-E 1.200-24 / GSA-E 1.200-24 HV THREADING MACHINES



PIC: GSA-E 1.200-24  
WITH OPTIONAL  
CLAMPING TABLE AND  
DIGITAL DISPLAY

## GSA-E 1.000-16 / GSA-E 1.000-16 HV / GSA-E 1.200-24 / GSA-E 1.200-24 HV

Electrically driven threading machines for thread cutting in through or blind holes from M16 to M24.

The Threads are cut quickly and precisely by the movable articulated arm. They are always exactly vertically and parallel to each other.

For HV versions, the cutting head can be brought into a horizontal position by 90°.

Our electric thread cutting machines are able to cut threads semi-automatically.

The digital display can be used to differentiate between automatic and manual mode: Thread depth and speed are adjustable.

The electric actuator requires no maintenance, has low operating costs, and is quieter than a pneumatic actuator.

Scope of delivery:

- » flexible articulated arm
- » mounting flange for table or workbench
- » electric motor
- » quick-change chuck and thread tap holders (8 pieces)

### OPTIONAL ACCESSORIES

- » clamping table

Mounting bracket set for DIN / ISO on request.

Description	GSA-E 1.000-16	GSA-E 1.000-16 HV	GSA-E 1.200-24	GSA-E 1.200-24 HV
cutting capacity	M3 - M16	M3 - M16	M6 - M24	M6 - M24
cutting direction	vertical	vertical and horizontal	vertical	vertical and horizontal
speeds	max. 300 min <sup>-1</sup>	max. 300 min <sup>-1</sup>	max. 200 min <sup>-1</sup>	max. 200 min <sup>-1</sup>
boom radius	max. 1.000 mm	max. 1.000 mm	max. 1.200 mm	max. 1.200 mm
drive	electric	electric	electric	electric
weight	25 kg	26 kg	50 kg	52 kg
	<b>GSA-E 1.000-16</b>	<b>GSA-E 1.000-16 HV</b>	<b>GSA-E 1.200-24</b>	<b>GSA-E 1.200-24 HV</b>
<b>EAN</b>	<b>4260364297744</b>	<b>4260364297751</b>	<b>4260364297720</b>	<b>4260364297768</b>
<b>Item no.</b>	<b>215 1016</b>	<b>215 1116</b>	<b>215 1024</b>	<b>215 1124</b>

# RB 40

## RADIAL DRILLING MACHINE

**NEW**



Radial Drilling Machine

Description	RB 40
drilling cap in steel	40 mm
sleeve travel	280 mm
spindle taper	MT 4
spindle speeds	32 - 2.500 min <sup>-1</sup>
speeds	16
automatic drilling feed	0,10 - 1,25 mm/rev
working range	300 - 1.300 mm
table size dice table	600 x 450 x 450 mm
T-slot size (table)	18 mm
T-slot number (table)	5
T-slot size (baseplate)	22 mm
T-slot number (baseplate)	3
column diameter	280 mm
distance spindle nose - table	300 - 1.120 mm
motor power	400 V / 2,2 kW / 3 kW
dimension (W x D x H)	2.100 x 900 x 2.490 mm
weight	2.500 kg
	<b>RB 40</b>
<b>EAN</b>	4260364298192
<b>Item No.</b>	215 0040

### RB 40

Very stable radial drilling machine with powerful drive, ergonomically designed for easy operation.

- » grounded and strong column
- » heavily ribbed boom
- » dice table machined on both sides with t-slots
- » control panel with function keys
- » LED-working light
- » thread cutting device

**Other sizes of the machine on request, our sales engineers will be happy to advise you.**

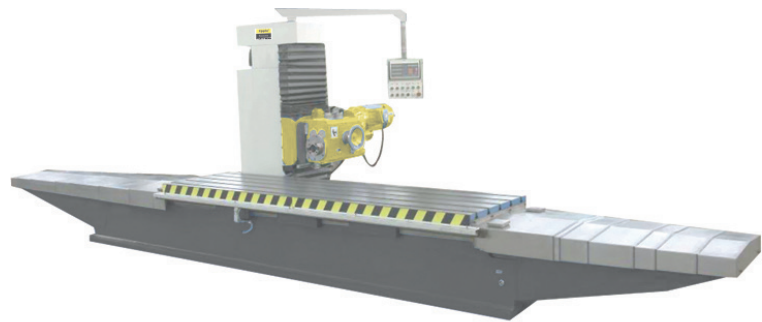
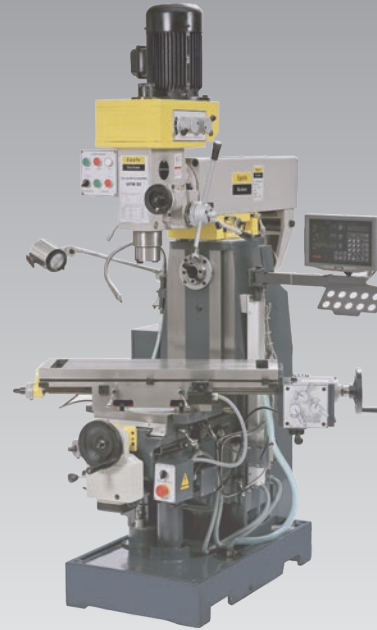

# Milling Machines

# BFM 16 VARIO / BFM 20 VARIO BFM 20 L VARIO / BFM 28 VARIO

## DRILLING-MILLING MACHINES

# Drilling- Milling Machines



PIC: BFM 16 VARIO



PIC: BFM 20 VARIO  
WITH OPTIONAL STAND



PIC: BFM 28 VARIO

Description	BFM 16 Vario	BFM 20 Vario	BFM 20 L Vario	BFM 28 Vario
drilling cap in steel	max. 16 mm	max. 16 mm	max. 16 mm	max. 28 mm
milling cap cutter head	max. 52 mm	max. 52 mm	max. 52 mm	max. 52 mm
milling cap end mill cutter	max. 16 mm	max. 20 mm	max. 20 mm	max. 20 mm
working range	175 mm	185 mm	185 mm	200 mm
head rotation	+45° / -90°	+45° / -90°	+45° / -90°	+45° / -90°
spindle taper	MT 2	MT 2	MT 2	MT 3
motor	variable speed	variable speed	variable speed	variable speed
spindle speeds	50 - 2.250 min <sup>-1</sup>	50 - 2.250 min <sup>-1</sup>	50 - 2.250 min <sup>-1</sup>	100 - 3.000 min <sup>-1</sup>
sleeve travel	50 mm	50 mm	50 mm	50 mm
table size	400 x 140 mm	500 x 180 mm	700 x 180 mm	700 x 180 mm
right / left rotation	no	no	no	yes
X-axis travel	220 mm	280 mm	480 mm	490 mm
Y-axis travel	160 mm	175 mm	175 mm	155 mm
Z-axis travel	210 mm	280 mm	280 mm	280 mm
T-slot size (table)	10 mm	12 mm	12 mm	12 mm
T-slot number (table)	3	3	2	3
motor power	230 V / 50 Hz / 0,6 kW	230 V / 50 Hz / 0,75 kW	230 V / 50 Hz / 0,75 kW	230 V / 50 Hz / 1,0 kW
dimensions (L x D x H)	550 x 530 x 760 mm	670 x 550 x 860 mm	770 x 550 x 860 mm	870 x 570 x 860 mm
weight	68 kg	103 kg	115 kg	140 kg
	<b>BFM 16 Vario</b>	<b>BFM 20 Vario</b>	<b>BFM 20 L Vario</b>	<b>BFM 28 Vario</b>
<b>EAN</b>	<b>4260364290226</b>	<b>4260364290233</b>	<b>4260364290240</b>	<b>4260657650294</b>
<b>Item No.</b>	<b>235 1116</b>	<b>235 1120</b>	<b>235 1125</b>	<b>235 1128</b>



# BFM 35 VARIO

## DRILLING-MILLING MACHINES



PIC: BFM 35 VARIO  
WITH OPTIONAL STAND

Description	BFM 35 Vario
drilling cap in steel	max. 32 mm
milling cap cutter head	max. 80 mm
milling cap end mill cutter	max. 20 mm
working range	220 mm
head rotation	+45° / -90°
spindle taper	MT 3
motor	variable speed
spindle speeds	50 - 2.250 min <sup>-1</sup>
sleeve travel	75 mm
table size	700 x 210 mm
X-axis travel	425 mm
Y-axis travel	220 mm
Z-axis travel	370 mm
T-slot size (table)	14 mm
T-slot number (table)	2
motor power	230 V / 1,1 kW
dimensions (L x D x H)	1.120 x 1.100 x 1.100 mm
weight	260 kg

	BFM 35 Vario
<b>EAN</b>	4260364290257
<b>Item No.</b>	235 1135

### BFM - Models

- » spindle sleeve feed for milling via handwheel
- » stepless electronically controlled drive
- » wide speed range
- » digital LED speed display
- » Safety device with emergency stop switch
- » mechanical sleeve entry for drilling
- » hollow spindle with M 10 drawbar for tool holder (M12 for BFM 35 Vario)
- » massive and precisely finished cross table, large dimensioned
- » X-axis: infinitely variable feed (only BFM 35 Vario)
- » **table feed with fast gear** (only BFM 35 Vario)
- » travel is readable on scales
- » adjustable wedges
- » versatile use of the machine
- » drilling/milling head rotating to the right 45°, to the left 90° (scale division up to 55°) (from BFM 45)
- » mechanical adjustable limit stops
- » solid dovetail slideway, ensures highest stability and highest possible precision
- » guiding protection by bellows (except model BFM 16 Vario)
- » right / left rotation (only model BFM 35 Vario)

### OPTIONAL EQUIPMENT

- » stand
- » HSS-end mill cutter kit
- » coolant system
- » collet chuck: MT 2 / MT 3
- » clamp kit: SPW 10 (BFM 20, BFM 20 L)  
SPW 12 (BFM 35, BFM 45)
- » milling vices
- » hand wheels with digital display

	Description	Item-No.
	Quick Action Drill Chuck RÖHM 1-13 mm	510 3013
	Quick Action Drill Chuck RÖHM 3-16 mm	510 3016
	HSS Drill Bit Set	510 9013
	MSE 75	121 0075
	MSE 100	121 0100
	MSE 125	121 0125
	MSE 150	121 0150

	BFM 20 Vario / BFM 20 L Vario stand	BFM 35 Vario stand
<b>EAN</b>	4260364293104	4260364293111
<b>Item No.</b>	535 0020	535 0035

## BFM 30 PG / BFM 45 PG / BFM 45 PG VARIO / BFM 45 PGV GEARED DRILLING-MILLING MACHINES



PIC: BFM 30 PG



PIC: BFM 45 PG VARIO



PIC: BFM 45 PG  
OPTIONAL WITH  
STAND

**NEW**

Description	BFM 30 PG	BFM 45 PG	BFM 45 PG Vario	BFM 45 PGV
drilling cap in cast iron	32 mm	50 mm	50 mm	50 mm
drilling cap in steel	28 mm	45 mm	45 mm	45 mm
end mill cap	16 mm	max. 32 mm	max. 32 mm	max. 32 mm
threading in steel max.	M 10	M 12	M 12	M 12
working range	320 mm	265 mm	265 mm	265 mm
distance spindle to table max.	410 mm	460 mm	460 mm	460 mm
head movement	+45° / -90°	+45° / -90°	+45° / -90°	+45° / -90°
spindle taper	MT 3	MT 4	MT 4	MT 4
motor	2-steps	2-steps	1-step	2-steps
no. of speeds	12	12	stepless	12
mechanic automatic drilling feed	no	no	no	yes
spindle speeds	95 - 2.840 min <sup>-1</sup>	95 - 3.200 min <sup>-1</sup>	75 - 3.200 min <sup>-1</sup>	95 - 3.200 min <sup>-1</sup>
sleeve travel	70 mm	130 mm	130 mm	130 mm
height adjustable mill head	310 mm	410 mm	410 mm	410 mm
table size	700 x 190 mm	800 x 240 mm	800 x 240 mm	800 x 240 mm
cross table movement (X, Y)	360 x 190 mm	560 x 200 mm	560 x 200 mm	560 x 200 mm
T-slot size (table)	12 mm	14 mm	14 mm	14 mm
T-slot number (table)	2	4	3	4
motor power	400 V / 0,6 kW / 0,75 kW	400 V / 1,3 kW / 1,8 kW	400 V / 1,5 kW	400 V / 1,3 kW / 1,8 kW
dimensions (L x D x H)	740 x 720 x 1.080 mm	1.100 x 850 x 1.430 mm	1.160 x 980 x 1.520 mm	1.100 x 850 x 1.430 mm
weight	210 kg	330 kg	330 kg	350 kg
	<b>BFM 30 PG</b>	<b>BFM 45 PG</b>	<b>BFM 45 PG Vario</b>	<b>BFM 45 PGV</b>
<b>EAN</b>	4260657650300	4260364290264	4260364294293	4260364290271
<b>Item No.</b>	235 1130	235 1145	235 1245	235 2145

# BFM 45 PGDV DIGI

## GEARED DRILLING-MILLING MACHINES

### BFM 45 - MODELS

UNIVERSAL PRECISE-MILLING / DRILLING MACHINE

- » gearbox running in oil bath (not at vario machines)
- » heavy cast iron construction
- » height of head adjustable via spindle
- » sleeve feed via hand lever, fine adjustment via hand wheel
- » large speed range
- » variable speed control (**BFM 45 PG Vario**)
- » 2-step motor
- » 12 speeds (BFM 45 PG, BFM 45 PGDV DIGI)
- » clockwise / anticlockwise rotation
- » safety device with emergency stop switch
- » high accurate spindle running due to taper roller bearings
- » mechanical feed of spindle sleeve for drilling via sleeve lever
- » thread cutting device
- » 3-stage vertical feed model: BFM 45 PGV und PGDV DIGI
- » drill depth stop
- » adjustable wedges
- » gear head rotation 90° to the right, 45° to the left
- » electrical head and table feed (**only for BFM 45 PGDV DIGI**)
- » coolant system (**only for BFM 45 PGDV DIGI**)
- » LED-working light (**only for BFM 45 PGDV DIGI**)
- » machine stand (**only for BFM 45 PGDV DIGI**)



PIC: BFM 45 PGDV DIGI

Description	BFM 45 PGDV DIGI
drilling cap in cast iron	45 mm
drilling cap in steel	32 mm
end mill cap	max. 32 mm
threading in steel max.	M 12
working range	265 mm
distance spindle to table max.	460 mm
head movement	+45° / -90°
spindle taper	MT 4
motor	2-steps
no. of speeds	12
mechanic automatic drilling feed	yes
spindle speeds	75 - 3.200 min <sup>-1</sup>
sleeve travel	120 mm
height adjustable mill head	410 mm
table size	800 x 240 mm
cross table movement	560 x 190 mm
T-slot size (table)	14 mm
T-slot number (table)	3
motor power	400 V / 0,85 kW / 1,1 kW
dimensions (L x D x H)	1.220 x 930 x 2.110 mm
weight	480 kg
	<b>BFM 45 PGDV DIGI</b>
<b>EAN</b>	<b>426036424316</b>
<b>Item No.</b>	<b>235 3245</b>

**BFM 45 PG** : manual feed  
**BFM 45 PG Vario** : manual feed  
**BFM 45 PGV** : automatic feed

### OPTIONAL ACCESSORIES

- » LED working light
- » HSS end mill cutter kit
- » coolant system
- » collet chuck MT 2
- » clamp kit SPW 12
- » milling vices
- » universal stand

# BFM 50 PG

## GEARED DRILLING-MILLING MACHINE



### BFM 50 PG

UNIVERSAL MILLING / DRILLING MACHINE WITH TABLE FEED, COOLANT SYSTEM, LED WORKING LIGHT AND STAND.

Geared head with solid dovetail slideway. Dovetail slideway in all 3 axes, hand-scraped, providing highest stability and precision. Universal precision drilling-milling machine - solid cast iron design.

- » quenched gearwheels immersed running in oil
- » hollow spindle to clamp tools via M 16 drawbar
- » sleeve feed for milling via handwheel
- » large speed range
- » 8 speeds (4 speeds over gear shift and 2-speed motor)
- » clockwise / anticlockwise rotation
- » safety device with emergency stop switch
- » high accurate spindle running due to taper roller bearings
- » mechanical spindle feed for drilling via cross lever
- » coupling for changeover of manual coarse feed in hand-fine feed
- » drill depth stop
- » massive exact cross table, large dimensioned with precise surface finishing with adjustable wedges and rotatable by 45° to the left and right
- » standard with mechanical feed for the X-axis with 8 speeds
- » coolant device
- » LED working light
- » gear head rotation +/-90°

Description	BFM 50 PG
drilling cap in cast iron	50 mm
drilling cap in steel	35 mm
milling cap cutter head	max. 100 mm
end mill cap	max. 32 mm
threading in steel max.	up to M 16
working range	320 mm
distance spindle to table max.	275 mm
head rotation	90°
spindle taper	ISO 40
motor	2-steps
no. of speeds	8 speeds (4 speeds via transmission circuit and 2- speed motor)
spindle speeds rpm	115/230/290/360/580/720/875/1.750 min <sup>-1</sup>
sleeve travel	120 mm
height adjustable mill head	350 mm
table feed speeds	24/60/65/100/185/285/470/720 mm/min + additional overdrive
table size	800 x 240 mm
cross table movement	400 x 230 mm
T-slot size (table)	14 mm
T-slot number (table)	4
motor power	400 V / 0,85 kW / 1,5 kW
dimensions (L x D x H)	1.175 x 870 x 2.100 mm
weight	560 kg
	<b>BFM 50 PG</b>
<b>EAN</b>	<b>4260364290288</b>
<b>Item No.</b>	<b>235 1150</b>



Automatic feed for the X-axis as standard (8 speeds)

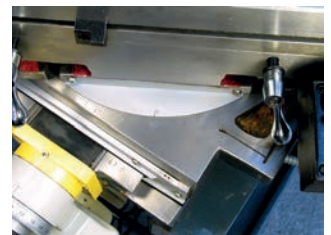

Cross Table rotatable by 45° to the left and right

### OPTIONAL ACCESSORIES

- » HSS end mill cutter kit
- » collet chuck ISO 40
- » clamp kit
- » milling vices
- » rotary tables

You can find detailed accessories on page 289.



# BFM 60 DIGI

## GEARED DRILLING-MILLING MACHINE



**NEW**

**BFM 60 DIGI**  
PROFESSIONAL MILLING AND DRILLING MACHINE WITH TABLE FEED, COOLANT SYSTEM AND LED WORKING LIGHT.

Universal precision drilling-milling machines, solid cast iron construction. Geared head with solid dovetail slideway, dovetail slideway in all 3 axes, hand-scraped, providing highest stability and precision. A total of 4 dovetail guides.

- » quenched gearwheels immersed running in oil
- » hollow spindle for tool clamping via M 16 drawbar
- » sleeve feed vertical via hand lever (e.g. for drilling)
- » large speed range
- » 8 speeds (2-step motor, thus 2x4 gear steps)
- » high accurate spindle running due to taper roller bearings
- » mechanical spindle feed for drilling via cross lever
- » drive coupling for shifting between rough and fine feed
- » drill depth stop
- » easy operating safety switch with low-voltage release and emergency stop
- » massive exact cross table, large dimensioned with precise surface finishing
- » cross table 45° to left and the right pivotable
- » forward and reverse for threading
- » automatic feed for the X-axis as standard (8 speeds)
- » cooling liquid facility
- » LED working light
- » gear head rotation +/-90°
- » standard mounted, clear and user-friendly digital LED display for exact display and measurement of travel distances.

Description	BFM 60 DIGI
drilling cap in cast iron	40 mm
drilling cap in steel	30 mm
milling cap cutter head	max.80 mm
end mill cap	max. 25 mm
threading in steel max.	up to M 14
working range	260 bis 650 mm
distance spindle to table max.	370 mm
spindle head rotation	90°
spindle taper	ISO 40
motor	2-steps
no. of speeds	5
spindle speeds rpm	115 - 1.750 min <sup>-1</sup>
sleeve travel	120 mm
height adjustment cross table	300 mm
table feed speeds	5 + overdrive
longitudinal table feed	24 - 720 mm/min
table size	800 x 240 mm
cross table movement	lengthwise (X): 380 mm, crosswise (Y): 220 mm, vertical (Z): 255 mm
T-slot size (table)	14 mm
T-slot number (table)	5
motor power	400 V / 0,85 kW / 1,5 kW
dimensions (L x D x H)	1.150 x 1.140 x 2.300 mm
weight	800 kg

	BFM 60 DIGI
<b>EAN</b>	<b>4260657650720</b>
<b>Item No.</b>	<b>235 3340</b>



Precision grinding hardened table swivel from -45° to +45°

### OPTIONAL ACCESSORIES

- » HSS end mill cutter kit
- » collet chuck ISO 40
- » clamp kit SPW 12
- » milling vices
- » rotary tables

You can find detailed accessories on page 289.



## FM 50 S / FM 50 S DIGI GEARED DRILLING-MILLING MACHINE



PIC: FM 50 S DIGI

### OPTIONAL EQUIPMENT

- » HSS end mill cutter kit
- » collet chuck ISO 40
- » clamp kit SPW 12
- » milling vices
- » rotary tables

**Machine is available on request with longer table and larger longitudinal path.**

Description	FM 50 S	FM 50 S DIGI
drilling cap in cast iron	50 mm	50 mm
drilling cap in steel	35 mm	35 mm
milling cap cutter head	max. 100 mm	max. 100 mm
end mill cap	max. 32 mm	max. 32 mm
threading in steel max.	up to M 16	up to M 16
working range	170 bis 690 mm	170 bis 690 mm
distance spindle to table max.	340 mm	340 mm
spindle head rotation	90°	90°
spindle taper	ISO 40	ISO 40
motor	2-steps	2-steps
no. of speeds	8	8
spindle speeds rpm	115 - 1.750 min <sup>-1</sup>	115 - 1.750 min <sup>-1</sup>
sleeve travel	120 mm	120 mm
height adjustment cross table	350 mm	350 mm
table feed speeds	8 + overdrive	8 + overdrive
longitudinal table feed	24 - 720 mm/min	24 - 720 mm/min
table size	800 x 240 mm	800 x 240 mm
cross table movement	lengthwise (X): 360 mm, crosswise (Y): 200 mm, vertical (Z): 345 mm	lengthwise (X): 360 mm, crosswise (Y): 200 mm, vertical (Z): 340 mm
T-slot size (table)	14 mm	14 mm
T-slot number (table)	5	5
motor power	400 V / 0,85 kW / 1,5 kW	400 V / 0,85 kW / 1,5 kW
dimensions (L x D x H)	1.200 x 1.120 x 2.060 mm	1.200 x 1.120 x 2.060 mm
weight	770 kg	780 kg
	<b>FM 50 S</b>	<b>FM 50 S DIGI</b>
<b>EAN</b>	<b>4260364290295</b>	<b>4260364290301</b>
<b>Item No.</b>	<b>235 2350</b>	<b>235 3350</b>

**FM 50 S / FM 50 S DIGI**  
PROFESSIONAL MILLING AND DRILLING MACHINE WITH TABLE FEED, COOLANT SYSTEM AND LED WORKING LIGHT.

Universal precision drilling-milling machines, solid cast iron construction. Geared head with solid dovetail slideway, dovetail slideway in all 3 axes, hand-scraped, providing highest stability and precision. A total of 4 dovetail guides.

- » quenched gearwheels immersed running in oil
- » hollow spindle for tool clamping via M 16 drawbar
- » sleeve feed vertical via hand lever (e.g. for drilling)
- » large speed range
- » 8 speeds (2-step motor, thus 2x4 gear steps)
- » high accurate spindle running due to taper roller bearings
- » mechanical spindle feed for drilling via cross lever
- » drive coupling for shifting between rough and fine feed

- » drill depth stop
- » easy operating safety switch with low-voltage release and emergency stop
- » massive exact cross table, large dimensioned with precise surface finishing
- » cross table 45° to left and the right pivotable
- » forward and reverse for threading
- » automatic feed for the X-axis as standard (8 speeds)
- » cooling liquid facility
- » LED working light
- » gear head rotation +/-90°
- » FM 50 S Digi: Standard mounted, clear and user-friendly digital LED display for exact display and measurement of travel distances.















cross table rotatable 45° to the left and 45° to the right.



DIGI model with easy to operate LED display for precise position readout and measurement of travel distances. DIGI-Machines exclusive.

You can find detailed accessories at page 289.

Description	Item-No.	Description	Item-No.
 Shank Cutter Cartridge	535 1020	 Precision parallels	535 0028
 Milling vice FMS	-	 Mounting Set	-
 Milling vice FMSN	-	 Collet Chucks and Collets	-
 Milling vice FS 16-200	520 3070	 Morse Taper	-
 Morse Taper Drill Case 1	510 1423	 Reducing Sleeves	-
 Morse Taper Drill Case 2	510 1430	 Extensions Sleeves	-

## UFM 80 DIGI / UFM 80 L DIGI UNIVERSAL DRILLING-MILLING MACHINE



### OPTIONAL ACCESSORIES

- » HSS end mill cutter kit
- » collet chuck ISO 40
- » clamp kit SPW 12
- » milling vices
- » rotary tables

**NEW**

Description	UFM 80 DIGI	UFM 80 L DIGI
drilling cap in cast iron	50 mm	50 mm
drilling cap in steel	35 mm	35 mm
sleeve travel	120 mm	120 mm
working range	170 - 690 mm	170 - 690 mm
distance spindle to table max.	360 mm	360 mm
spindle head rotation	90°	90°
spindle taper	ISO 40	ISO 40
no. of speeds	8 speeds	8 speeds
spindle speeds rpm	115 - 1.750 min <sup>-1</sup>	115 - 1.750 min <sup>-1</sup>
speed range horizontal spindle	60 - 1.350 min <sup>-1</sup>	60 - 1.350 min <sup>-1</sup>
height adjustment cross table	350 mm	350 mm
table feed speeds X-axis	8 gear steps + fast gear (24 - 720 mm/min.)	8 gear steps + fast gear (24 - 720 mm/min.)
table feed speeds Y-axis	el. feed - infinitely variable + fast speed	el. feed - infinitely variable + fast speed
table size	800 x 240 mm	1.120 x 280 mm
cross table movement X x Y x Z	365 x 185 x 360 mm	600 x 230 x 360 mm
T-slot size (table)	14 mm	14 mm
T-slot number (table)	5	5
motor power	400 V / 0,85 kW / 1,5 kW	400 V / 1,5 kW / 2,2 kW
dimensions (L x D x H)	1.200 x 1.120 x 2.060 mm	1.600 x 1.400 x 2.222 mm
weight	970 kg	1.120 kg
	<b>UFM 80 DIGI</b>	<b>UFM 80 L DIGI</b>
<b>EAN</b>	<b>4260364290318</b>	<b>4260657650324</b>
<b>Item No.</b>	<b>235 3380</b>	<b>235 3480</b>

**UFM 80 DIGI / UFM 80 L DIGI**  
INDUSTRIAL MACHINE FOR SINGLE AND SMALL BATCH PRODUCTION

Professional drilling and milling machine with horizontal and vertical spindle, longitudinal (X) and cross (Y) table feed, 3-axes digital readout system, coolant system and halogen working light. Geared head with solid dovetail slideway. Dovetail slideway in all 3 axes, hand-scraped, providing highest stability and precision.

- » quenched gearwheels immersed running in oil
- » hollow spindle for tool clamping by M 16 drawbar
- » fine spindle crossfeed sleeve when milling
- » large speed range
- » 8 speeds (2-step motor, thus 2x4 gear steps)
- » mechanical spindle feed for drilling via cross lever

- » drive coupling for shifting between rough and fine feed
- » safety device with emergency stop switch
- » cross table height adjustable by crank
- » massive exact cross table, large dimensioned with precise surface finishing with adjustable wedges
- » cross table 45° to left and the right pivotable
- » standard table feeds: X-axis with 8 speeds, Y-axis stepless adjustable + rapid speed
- » cooling liquid facility
- » LED working light
- » gear head rotation +/-90°



DIGI model with easy to operate LED display for precise position readout and measurement of travel distances. DIGI-Machines exclusive.















Y-axis with stepless feed control



cross table rotation 45° to the left and right

You can find detailed accessories on page 289.

Description	Item No.	Description	Item No.
 Shank Cutter Cartridge	535 1020	 Precision parallels	535 0028
 Milling vice FMS	-	 Mounting Set	-
 Milling vice FMSN	-	 Collet Chucks and Collets	-
 Milling vice FS 16-200	520 3070	 Morse Taper	-
 Morse Taper Drill Case 1	510 1423	 Reducing Sleeves	-
 Morse Taper Drill Case 2	510 1430	 Extensions Sleeves	-

# WFM 80 DIGI

## TOOL MILLING MACHINE



PIC: WFM 80 DIGI

### WFM 80 DIGI TOOL MILLING MACHINE

Professional milling machine with vertical and horizontal spindle, table feed in X- and y-axis, as well as 3-axis digital device, coolant device and LED working light. Solid dovetail guide on the cross arm otherwise rectangular guides.

- » vertical milling head with spindle taper ISO 40 / DIN 2080, 60 mm quill stroke 90° rotatable on both sides.
- » hardened and grounded worktable 800 x 400 mm with T-slots 14 mm; Table load max 300 kg.
- » worktable, vertical milling head and boom are made of stress-free annealed quality cast iron, some with multiple ribs for better stability
- » mechanical safety handwheels with scale ring in all axes
- » ball screw in all 3 axes
- » automatic central lubrication

#### OPTIONAL ACCESSORIES

- » swivel table
- » table covering

Description	WFM 80 DIGI
table size	800 x 400 mm
travel	lengthwise (X): 500 mm crosswise (Y): 400 mm vertical (Z): 400 mm
table load	max. 300 kg
max. distance spindle- table	405 mm
spindle head swivel range	90°
spindle taper	ISO 40
no. of speeds	18 speeds
speeds of vertical spindle	40 - 2.000 min <sup>-1</sup>
speeds of horizontal spindle	40 - 2.000 min <sup>-1</sup>
sleeve stroke	60 mm
table height adjustment	400 mm
feed speed X-axis	(18) 10 - 1.000 mm/min
feed speed Y-axis	(18) 10 - 1.000 mm/min
feed speed Z-axis	(18) 10 - 1.000 mm/min
rapid traverse (X / Y / Z)	1.200 mm/min
T-slot size (table)	14 mm
T-slot number (table)	8
motor power	400 V / 50 Hz / 3,7 kW
dimensions (L x W x H)	1.650 x 1.770 x 1.880 mm
weight	1.550 kg

	WFM 80 DIGI
EAN	4260364295702
Item No.	245 3480

You can find detailed accessories on page 289.



# DF 2 DIGI / DF 4 DIGI TOOL MILLING MACHINE



PIC: DF 4 DIGI  
WITH OPTIONAL TABLE COVERING

## DF 2 DIGI / DF 4 DIGI TOOL MILLING MACHINE

High quality and stable universal milling & drilling machine, with high precision, durability and maximum operating comfort.

- » vertical milling head with spindle taper ISO 40 / DIN 2080, 60 mm quill stroke 90° tiltable on both sides.
- » hardened guideways, ground, adjustable.
- » surface worktable ground with T-slots
- » mechanical safety handwheels with scale ring in all axes.
- » ball screw in all 3 axes.
- » manual central lubrication (DF 2 Digi)
- » automatic central lubrication (DF 4 Digi)

### STANDARD ACCESSORIES

- » 3-axis-digital readout system
- » cooling device
- » LED working light

### OPTIONAL ACCESSORIES

- » swivel table
- » table covering

Description	DF 2 DIGI	DF 4 DIGI
table size	750 x 320 mm	900 x 500 mm
travel	lengthwise (X): 400 mm crosswise (Y): 200 mm vertical (Z): 360 mm	lengthwise (X): 600 mm crosswise (Y): 480 mm vertical (Z): 360 mm
table load	max. 285 kg	max. 360 kg
max. distance spindle - table	450 mm	460 mm
spindle head swivel range	90°	90°
spindle taper	ISO 40	ISO 40
no. of speeds	12 speeds	18 speeds
speeds of vertical spindle	50 - 2.000 min <sup>-1</sup>	40 - 2.000 min <sup>-1</sup>
speeds of horizontal spindle	50 - 2.000 min <sup>-1</sup>	40 - 2.000 min <sup>-1</sup>
sleeve stroke	120 mm	120 mm
table height adjustment	360 mm	360 mm
feed speed X-axis	(18) 10 - 650 mm/min	(18) 10 - 450 mm/min
feed speed Y-axis	(18) 10 - 650 mm/min	(18) 10 - 450 mm/min
feed speed Z-axis	(18) 10 - 650 mm/min	(18) 10 - 450 mm/min
rapid traverse (X / Y / Z)	1.200 mm/min	800 / 800 / 680 mm/min
T-slot size (table)	14 mm	14 mm
T-slot number (table)	5	7
motor power	400 V / 50 Hz / 2,2 kW	400 V / 50 Hz / 3,7 kW
dimensions (L x W x H)	1.180 x 1.450 x 1.800 mm	1.400 x 1.780 x 1.820 mm
weight	1.350 kg	1.770 kg

	DF 2 DIGI	DF 4 DIGI
EAN	4260364297881	4260364297898
Item No.	245 3475	245 3490

You can find detailed accessories on page 289.

# VFM 95 / VFM 95 DIGI

## VERTICAL MILLING MACHINES

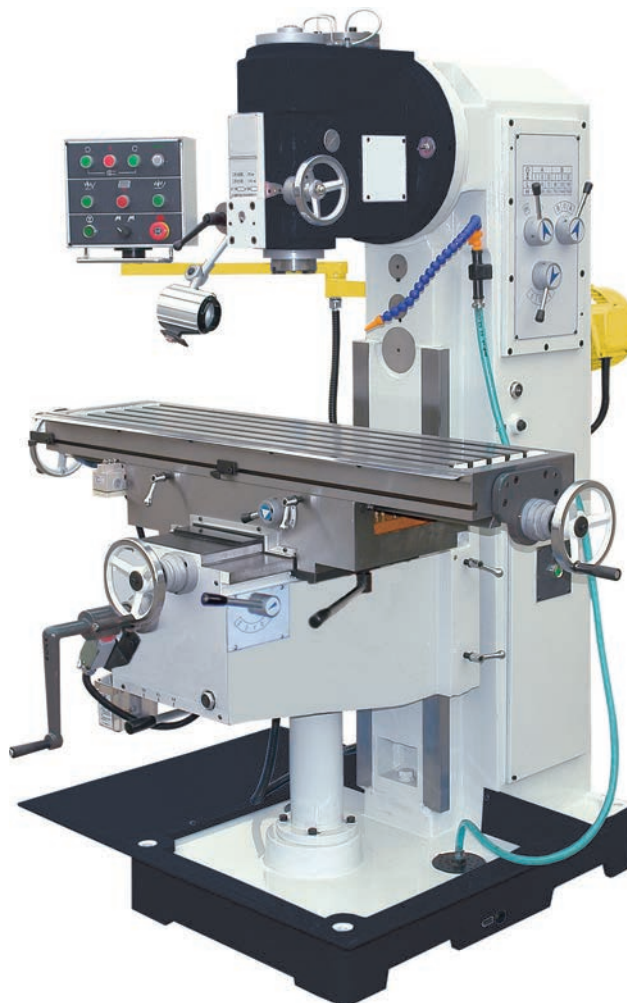

PIC: VFM 95  
WITHOUT DRO

Vertical Milling Machines

### VFM 95 / VFM 95 DIGI VERTICAL MILLING MACHINE

- » powerful vertical milling machine with gearbox
- » gear wheels hardened and ground
- » machine frame with particularly stable wide guides in all axes
- » +/- 30° swiveling, extremely stable milling head
- » manual spindle sleeve feed with fine adjustment
- » stepless variable feeds and rapid traverse at the table and console, standard with LED working light, coolant device and chip tray
- » digital display with 3-axis (only model VFM 95 DIGI)

Description	VFM 95	VFM 95 DIGI
working range	450 mm	450 mm
spindle taper	ISO 40	ISO 40
spindle speeds	12	12
speeds of vertical spindle	35 - 1.500 rev/min	35 - 1.500 rev/min
table feed speed	X,Y: 30 - 830 mm/min Z: 23 - 625 mm/min	X,Y: 30 - 830 mm/min Z: 23 - 625 mm/min
table overdrive	1.335/1.335/1.000 mm/min	1.335/1.335/1.000 mm/min
table size	1.270 x 300 mm	1.270 x 300 mm
travel	lengthwise 720 mm crosswise 300 mm vertical 400 mm	lengthwise 720 mm crosswise 280 mm vertical 400 mm
T-slot size (table)	14	14
T-slot number (table)	3	3
dimensions (L x D x H)	1.720 x 1.680 x 1.810 mm	1.720 x 1.680 x 1.810 mm
weight	1.500 kg	1.510 kg
	<b>VFM 95</b>	<b>VFM 95 DIGI</b>
<b>EAN</b>	<b>4260364295719</b>	<b>4260364295726</b>
<b>Item No.</b>	<b>235 2495</b>	<b>235 3495</b>

# VHFM 95 / VHFM 95 DIGI

## VERTICAL MILLING MACHINES



PIC: VHFM 95  
WITHOUT DRO

### VHFM 95 / VHFM 95 DIGI VERTICAL MILLING MACHINE

- » vertical milling machine with horizontal spindle and vertical milling head
- » gear with hardened and ground gear wheels
- » machine frame with stable guides in all axes
- » table and consoles with stepless adjustable feeds and rapid traverse, standard with LED working light, coolant device and chip tray
- » digital display with 3-axis (only model VHFM 95 DIGI)

Description	VHFM 95	VHFM 95 DIGI
working range	285 mm	285 mm
spindle taper	ISO 40	ISO 40
spindle speeds	12	12
speeds of vertical spindle	35 - 1.500 rev/min	35 - 1.500 rev/min
table feed speed	X,Y: 30 - 830 mm/min Z: 23 - 625 mm/min	X,Y: 30 - 830 mm/min Z: 23 - 625 mm/min
table overdrive	1.335/1.335/1.000 mm/min	1.335/1.335/1.000 mm/min
table size	1.270 x 300 mm	1.270 x 300 mm
travel	lengthwise 900 mm crosswise 380 mm vertical 400 mm	lengthwise 900 mm crosswise 360 mm vertical 400 mm
T-slot size (table)	14	14
T-slot number (table)	3	3
dimensions (L x D x H)	1.720 x 1.680 x 1.730 mm	1.720 x 1.680 x 1.730 mm
weight	1.600 kg	1.610 kg
	<b>VHFM 95</b>	<b>VHFM 95 DIGI</b>
<b>EAN</b>	<b>4260364295733</b>	<b>4260364295740</b>
<b>Item No.</b>	<b>235 2595</b>	<b>235 3595</b>

# UFM 100 DIGI

## UNIVERSAL MILLING MACHINE



### OPTIONAL ACCESSORIES

- » HSS end mill cutter kit
- » collet chuck ISO 40
- » clamp kit SPW 12
- » milling vices
- » rotary tables

For technical data check page 49.

### UFM 100 DIGI

Professional milling machine with universal horizontal and vertical gear head spindle, longitudinal (X) and cross (Y) table feeds, 3-axes digital readout system, coolant system, LED working light. Solid, heavy cast iron body for vibrationless operations; with accurate, large and precise ground surface cross table. Geared head with solid dovetail slideway. Dovetail slideway in every 3 axes, hand-scraped, providing highest stability and precision.

Multifunctional universal milling machine for production factories, toolmakers or work-shops. Precision universal milling machine for professional use at an economical price.

- » massive cast iron construction
- » milling head pivotable in any angle
- » stable in value and low priced
- » quenched gearwheels immersed running in oil
- » toolclamping system with M16 screw
- » right / left rotation
- » safety device with emergency stop switch
- » 11 speeds
- » large, precise cross table to use for longer and heavier work pieces

- » cross table electrically and mechanically adjustable
- » cross table with precise surface finishing with adjustable wedges
- » large dimensioned handwheels for fine scale adjustment
- » 2 table feeds as standard
- » X- and Y-axis with 9 speeds with mechanical feeds
- » cooling liquid facility
- » LED working light
- » central lubrication
- » steady fixture for horizontal milling
- » standard mounted, clearly arranged and user-friendly digital LED display for exact display and measurement of the traverse paths
- » large chip tray
- » universal milling head 360° rotatable and manually in 2 levels can be swivelled in space

You can find detailed accessories on page 289.





control panel for 11 spindle speeds



X- and Y-axes with 9 table speeds



DIGI model with easy to operate LED display for precise position readout and measurement of traverse.

DIGI-Machines exclusive.

small figures to the right:

- 1.) control unit with digital device on swivelling ironing arm for ergonomic operation
- 2.) turnable and inclinable milling head, delivery without chip protection shield
- 3.) central lubrication
- 4.) control panel swivels to the left and right of the machine

You can find detailed accessories on page 289.

Description	UFM 100 DIGI
horizontal mill cap	125 mm
vertical mill cap	28 mm
face mill cap	85 mm
end mill cap	16 mm
working range	570 mm
distance spindle to table	120 - 460 mm
distance spindle to table max.	0 - 440 mm
swivel of milling head	360°
spindle taper	ISO 40
no. of speeds	11
vertical spindle speeds	40 / 75 / 105 / 180 / 200 / 320 / 370 / 475 / 650 / 820 / 1.600 min <sup>-1</sup>
horizontal spindle speeds	40 / 75 / 105 / 180 / 200 / 320 / 370 / 475 / 650 / 820 / 1.600 min <sup>-1</sup>
longitudinal table feed (x)	24 / 42 / 55 / 74 / 98 / 132 / 170 / 230 / 402 mm/min
cross table feed (y)	24 / 42 / 55 / 74 / 98 / 132 / 170 / 230 / 402 mm/min
table size	1.120 x 260 mm
cross table movement	lengthwise (X): 620 mm, crosswise (Y): 250 mm vertical (Z): 440 mm
T-slot size (table)	14
T-slot number (table)	3
motor power	400 V / 2,2 kW (H: 750 W) (V: 500 W) (P: 100 W)
dimensions (L x D x H)	1.650 x 1.325 x 1.655 mm
weight	1.660 kg
	<b>UFM 100 DIGI</b>
<b>EAN</b>	<b>4260364290325</b>
<b>Item No.</b>	<b>235 3310</b>

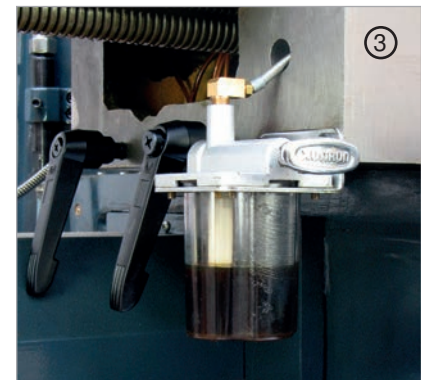



# UFM 200 DIGI

## UNIVERSAL MILLING MACHINE



For technical data check page 51.

### UFM 200 DIGI

Professional milling machine with universal horizontal and vertical gear head spindle, longitudinal (X) and cross (Y) table feeds, 3-axes digital readout system, coolant system, LED working light. Solid, heavy cast iron body for vibrationless operations; with accurate, large and precise ground surface cross table. Geared head with solid dovetail slideway. The UFM 200 has a total of 4 dovetail guides. Multifunctional milling machine for production companies, toolmakers or contractors.

A precision milling machine for professional use at a very good price-performance ratio. Simple operation due to an ergonomic design.

- » massive basic structure in heavy construction
- » milling head can be rotated to any spatial angle
- » stable in value and inexpensive
- » gear drive running in oil bath
- » hollow spindle around tool via M16 tightening rod to be clamped
- » right / left rotation
- » safety device with emergency stop switch
- » 11 speeds
- » large, precise cross table to use for longer and heavier work pieces

- » cross table electrically and mechanically adjustable
- » cross table with precise surface finishing with adjustable wedges
- » large dimensioned handwheels for fine scale adjustment
- » 3 table feeds as standard
- » X- and Y-axis with 9 speeds with mechanical feeds
- » cooling liquid facility
- » LED working light
- » central lubrication
- » steady fixture for horizontal milling
- » standard mounted, clearly arranged and user-friendly digital LED display for exact display and measurement of the traverse paths
- » large chip tray
- » universal milling head 360° rotatable and manually in 2 levels can be swivelled in space

### OPTIONAL EQUIPMENT

- » servo drive for all 3 axes

You can find detailed accessories on page 289.



control panel for 12 spindle speeds

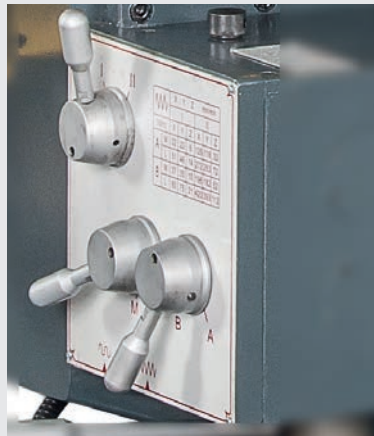

X-, Y- and Z-axes with 8 table speeds



DIGI model with easy to operate LED display for precise position readout and measurement of traverse.

DIGI-Machines exclusive.

small figures to the right:

- 1.) control unit with digital device on swivelling ironing arm for ergonomic operation
- 2.) turnable and inclinable milling head, delivery without chip protection shield
- 3.) central lubrication
- 4.) control panel swivels to the left and right of the machine

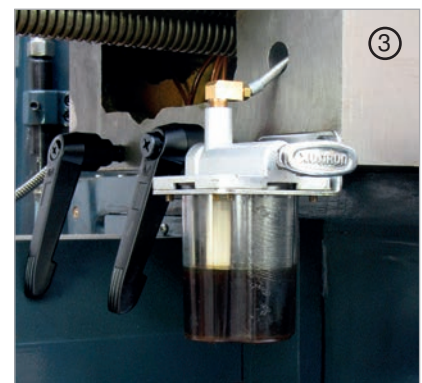

Description	UFM 200 DIGI
horizontal mill cap	130 mm
vertical mill cap	100 mm
face mill cap	20 mm
working range	820 mm
distance spindle to table	560 mm
distance spindle to table max.	0 - 400 mm
swivel of milling head	360°
spindle taper	ISO 50
no. of speeds	12
vertical spindle speeds	60 / 80 / 113 / 154 / 206 / 292 / 358 / 478 / 679 / 925 / 1.230 / 1.750
horizontal spindle speeds	58 / 78 / 108 / 148 / 208 / 288 / 388 / 535 / 720 / 980 / 1.325 / 1.800
longitudinal table feed (X)	22 / 37 / 51 / 80 / 126 / 196 / 272 / 420
cross table feed (Y)	22 / 35 / 48 / 75 / 118 / 182 / 253 / 393
table feed speed (Z)	10 / 15 / 20 / 30 / 50 / 78 / 108 / 168
table size	1.330 x 370 mm
cross table movement	lengthwise (X): 1.000 mm crosswise (Y): 280 mm vertical (Z): 400 mm
T-slot size (table)	14 mm
T-slot number (table)	3
motor power	400 V / 4,0 kW
dimensions (L x D x H)	1.720 x 1.900 x 1.950 mm
weight	2.200 kg
	<b>UFM 200 DIGI</b>
<b>EAN</b>	<b>4260364290332</b>
<b>Item No.</b>	<b>235 3320</b>

**UFM 260 DIGI / UFM 260-L DIGI**  
UNIVERSAL MILLING MACHINE

**NEW**



PIC: UFM 260 DIGI



PIC: central lubrication



PIC: gear shifting



PIC: control panel









**UFM 260 DIGI / UFM 260 L DIGI**

Particularly solid universal milling machine with large working area and large work table suitable for machining heavy workpieces.

- » universal swivel head, can be set at any spatial angle
- » gear wheels hardened and ground
- » large dovetail guides in the X-axis
- » solid rectangular guides in Y- and Z-axis
- » swivelling control panel
- » infinitely variable feed speeds in all 3 axes
- » 3-axis position display
- » automatic central lubrication
- » coolant system
- » operating tool
- » operating Instructions

You can find detailed accessories on page 289.

Description	UFM 260 DIGI	UFM 260-L DIGI
table size	1.600 x 500 mm	2.000 x 500 mm
table load max.	1.000 kg	1.800 kg
T-slot number (table)	5	5
T-slot size (table)	18 mm	18 mm
T-slots spacing	80 mm	80 mm
traverse path table X-axis	1.200 mm	1.400 mm
traverse path table Y-axis	700 mm	700 mm
traverse path table Z-axis	500 mm	500 mm
table feed X-axis	10 - 1.000 mm/min	10 - 1.000 mm/min
table feed Y-axis	10 - 1.000 mm/min	10 - 1.000 mm/min
table feed Z-axis	5 - 500 mm/min	5 - 500 mm/min
rapid traverse table X-axis	2.200 mm/min	2.200 mm/min
rapid traverse table Y-axis	2.200 mm/min	2.200 mm/min
rapid traverse table Z-axis	1.100 mm/min	1.100 mm/min
servo feed motor X- and Y-axis	15 Nm	15 Nm
servo feed motor Z-axis	18 Nm	18 Nm
distance table and spindle nose	50 - 550 mm	50 - 550 mm
universal milling head swivel range	360° (in 2 levels)	360° (in 2 levels)
spindle mount	ISO 50	ISO 50
spindle speeds	30 - 2.050 rev/min	30 - 2.050 rev/min
number of speeds	30	30
distance spindle center to column	45 - 745 mm	45 - 745 mm
motor power	400 V / 7,5 kW	400 V / 7,5 kW
dimensions (L x D x H)	2.460 x 2.625 x 2.080 mm	2.860 x 2.625 x 2.080 mm
weight	5.000 kg	5.500 kg
	<b>UFM 260 DIGI</b>	<b>UFM 260-L DIGI</b>
<b>EAN</b>	<b>4260657650331</b>	<b>4260657650348</b>
<b>Item no.</b>	<b>235 3260</b>	<b>235 4260</b>

Description	Item No.	Description	Item No.
 Shank Cutter Cartridge	535 1020	 Clamp Kit	-
 Milling Vices FMSN	-	 Collet Chucks and Collets	-
 Milling Vice FS 16-100	520 3050	 Transmission oil AR 150	580 1150
 Milling Vice FS 16-160	520 3060	 Coolant emulsion 5 litres	580 1030



# VFM 240 / VFM 240 DIGI

## VERTICAL MILLING MACHINE



PIC: VFM 240  
WITHOUT DRO

### VFM 240 / VFM 240 DIGI VERTICAL MILLING MACHINE WITH FIXED BED UNDER THE CROSS TABLE

Very stable bed milling machine for large workpieces and heavy chipping. Generous sized heavy cast frame and pillar with extremely wide flat guides. Stability and lower vibrations lead to more precision with high table load capacity. Hardened and grounded guides in all axis guides guarantee long-term accuracy.

- » milling head can be swiveled +/- 90° sideways
- » additionally with extendable sleeve, ISO 50 spindle taper
- » gear drive with 12 speeds
- » handwheels for exact adjustment with fine scaling
- » feed in X-, Y- and Z-axis and rapid traverse standard
- » coolant device
- » LED working light

VFM 240 DIGI with user-friendly digital position measuring system for exact display of the travel including possibilities of the coordinate specification, hole circle pattern calculation, storage for 10 tools and conversion mm / inch.

Description	VFM 240	VFM 240 DIGI
working range	105 mm	105 mm
distance spindle to table max.	600 mm	600 mm
swivel of milling head	±30°	±30°
spindle taper	ISO 50	ISO 50
motor	7,5 kW	7,5 kW
no. of speeds	12	12
vertical spindle speeds	66 - 1.440 rev/min	66 - 1.440 rev/min
quill stroke	105 mm	105 mm
table speeds	20 - 2.000 mm/min	20 - 2.000 mm/min
table overdrive	3.100 mm/min	3.100 mm/min
table size	2.000 x 400 mm	2.000 x 400 mm
max. table load	max. 2.000 kg	max. 2.000 kg
travel	lengthwise 1.500 mm crosswise 620 mm vertical (milling head) 550 mm	lengthwise 1.500 mm crosswise 620 mm vertical (milling head) 550 mm
T-slot size (table)	18	18
T-slot number (table)	5	5
dimensions (L x D x H)	2.420 x 2.340 x 3.000 mm	2.420 x 2.340 x 3.000 mm
weight	4.500 kg	4.500 kg
	<b>VFM 240</b>	<b>VFM 240 DIGI</b>
<b>EAN</b>	<b>4260364295757</b>	<b>4260364295764</b>
<b>Item No.</b>	<b>235 2424</b>	<b>235 3424</b>



# VFM 2150 SERVO

## BED-TYPE MILLING MACHINE

**NEW**



PIC: VFM 2150 SERVO

### VFM 2150 SERVO BED-TYPE MILLING MACHINE

Very stable bed-type milling machine for large workpieces and heavy chip removal. Generously dimensioned heavy cast frame and column with extremely wide flat guides. Stability and lower vibrations lead to more precision with high table load capacity. Hardened and ground guides in all axis guides guarantee many years of accuracy.

- » additionally with extendable quill, ISO 50 receptacle
- » ball screw drive on all axles
- » universal swivel head swivels easily into a horizontal position
- » electronic handwheels in all axes enable precise adjustment with fine scaling
- » servo motors in all axes, stepless feed, rapid traverse and speed control
- » coolant device
- » LED working light

Description	VFM 2150 Servo
table dimensions	2.100 x 500 mm
number of T-slots	4
dimension of the T-slots	20 mm / 100 mm
max. Table load	1.800 kg
travel	lengthwise 1.500 mm crosswise 650 mm vertical (milling head) 600 mm
spindle	ISO 50
rotation speed	2 stepped 6-300, 30-1500 U/min
vertical head angle adjustment	± 360
distance spindle - column surface	610 mm
distance spindle - worktable	0 - 650 mm
longitudinal - cross feed	2.5 - 3.000 mm/min
horizontal feed	2.5 - 2.500 mm/min
fast longitudinal cross feed	6.000 mm/min
fast horizontal feed	3.000 min/min
motor	11 kW
coolant pump motor	0,55 kW
dimensions (L x D x H)	3.300 x 2.420 x 2.800 mm
weight	7.300 kg
	<b>VFM 2150 Servo</b>
<b>EAN</b>	<b>4260657652120</b>
<b>Item No.</b>	<b>235 2150</b>

DRILLING  
MILLING  
TURNING  
SAWING  
GRINDING  
BENDING  
CUTTING / PRESSING  
OTHER MACHINES  
ACCESSORIES

# HFM 1560 / HFM 2060 HFM 2580 / HFM 3080 BED-TYPE MILLING MACHINES

**NEW**



PIC: HFM 3080

## HFM 1560 / HFM 2060 / HFM 2580 / HFM 3080 BED-TYPE MILLING MACHINE

Milling machine with mechanical gear, horizontal milling spindle and large work table for machining heavy workpieces. Machine bed, table and column made of high-quality cast iron. Large rectangular guides with telescopic covers.

### OPTIONAL ACCESSORIES

- » digital readout system
- » machine vice
- » coolant device
- » clamping device

Description	HFM 1560	HFM 2060	HFM 2580	HFM 3080
max distance spindle table	750 mm	750 mm	1.000 mm	1.000 mm
spindle taper	ISO 50	ISO 50	ISO 50	ISO 50
motor	7,5 kW	7,5 kW	7,5 kW	7,5 kW
no. of speeds	6	6	6	6
speeds	82 - 505 U/min	82 - 505 U/min	82 - 505 U/min	82 - 505 U/min
spindle swivelling	±35°	±35°	±35°	±35°
vertical feed	stepless	stepless	stepless	stepless
horizontal milling head travel	350 mm	350 mm	350 mm	350 mm
table speeds	stepless	stepless	stepless	stepless
rapid traverse	1.400 mm/min	1.400 mm/min	1.400 mm/min	1.400 mm/min
table drive	2,2 kW	2,2 kW	2,2 kW	2,2 kW
table size	1.500 x 630 mm	2.000 x 630 mm	2.500 x 800 mm	3.000 x 800 mm
max. table load	1.500 kg	1.500 kg	2.000 kg	2.000 kg
travel	1.500 mm	2.000 mm	2.500 mm	3.000 mm
T-slot size (table)	22 mm	22 mm	22 mm	22 mm
T-slot number (table)	5	5	5	5
dimensions (L x D x H)	4.600 x 2.200 x 2.300 mm	5.300 x 2.200 x 2.300 mm	6.000 x 2.200 x 2.600 mm	6.700 x 2.200 x 2.600 mm
weight	3.200 kg	3.800 kg	5.200 kg	6.600 kg
	<b>HFM 1560</b>	<b>HFM 2060</b>	<b>HFM 2580</b>	<b>HFM 3080</b>
<b>EAN</b>	<b>4260364298208</b>	<b>4260364298215</b>	<b>4260364298222</b>	<b>4260364298239</b>
<b>Item No.</b>	<b>235 1560</b>	<b>235 2060</b>	<b>235 2580</b>	<b>235 3080</b>



# Turning Machines

# TD 1803 VARIO / TD 2004 VARIO

## STEPLESS LATHE MACHINES

**THE ORIGINAL  
Epple Maschinen®**



PIC: TD 1803 VARIO WITH OPTIONAL STAND

### TD 1803 VARIO / TD 2004 VARIO

- » series in a modern design
- » stepless speed adjustment and digital speed display
- » hardened spindle nose
- » true running accuracy < 0,015 mm measured in the spindle nose
- » wide bed, inductively hardened
- » lead screw cover for a long lifespan
- » emergency stop with undervoltage release
- » standard with right/left rotation switch
- » handwheels with fine scaling

### INCLUDED

- » **3-jaw chuck 100 mm**
- » 2 solid tips
- » operating tool
- » chip tray
- » spray tank
- » 4-fold steel holder
- » change gear set
- » lathe chuck protection

Description	TD 1803 Vario	TD 2004 Vario
turning $\varnothing$ over machine bed	$\varnothing$ 180 mm	$\varnothing$ 210 mm
turning $\varnothing$ over compound sleds	$\varnothing$ 120 mm	$\varnothing$ 210 mm
centre width	300 mm	400 mm
centre height	90 mm	105 mm
spindle bore	$\varnothing$ 21 mm	$\varnothing$ 21 mm
spindle taper	MT 3	MT 3
3-jaw chuck	$\varnothing$ 100 mm	$\varnothing$ 100 mm
spindle speed	150 - 2.500 min <sup>-1</sup>	150 - 2.500 min <sup>-1</sup>
top slide - travel	40 mm	55 mm
compound slide - travel	55 mm	75 mm
pitch - metric	0,5 - 3,0 mm / rev	0,5 - 3,0 mm / rev
pitch - inch	10 - 44 Gg/1"	10 - 44 Gg/1"
speeds	stepless	stepless
tailstock sleeve travel	60 mm	60 mm
tailstock taper absorption	MT 2	MT 2
motor power	0,60 kW - 230 V / 50 Hz	0,60 kW - 230 V / 50 Hz
dimensions (L x D x H)	740 x 390 x 310 mm	840 x 390 x 370 mm
weight	44 kg	48 kg

	TD 1803 Vario	TD 2004 VARIO
<b>EAN</b>	4260364295795	4260364295801
<b>Item No.</b>	246 1813	246 2014

# TD 2406 / TD 2406 VARIO / TD 2506 / TD 2506 VARIO

## STEPLESS LATHE MACHINES

THE ORIGINAL  
Epple Maschinen®



PIC: TD 2406 VARIO WITH  
OPTIONAL STAND

### TD 2406 / TD 2406 VARIO / TD 2506 / TD 2506 VARIO

- » series in a modern design
- » stepless speed adjustment and digital speed display
- » hardened spindle nose
- » true running accuracy < 0,015 mm measured in the spindle nose
- » wide bed, inductively hardened
- » lead screw cover for a long lifespan
- » emergency stop with undervoltage release
- » standard with right/left rotation switch
- » handwheels with fine scaling

#### INCLUDED

- » **3-jaw chuck 125 mm**
- » 2 solid tips
- » operating tool
- » chip tray
- » splashback
- » 4-fold steel holder
- » change gear set
- » lathe chuck protection

Description	TD 2406	TD 2406 VARIO	TD 2506	TD 2506 VARIO
turning $\varnothing$ over machine bed	$\varnothing$ 250 mm	$\varnothing$ 250 mm	$\varnothing$ 250 mm	$\varnothing$ 250 mm
turning $\varnothing$ over compound sleds	$\varnothing$ 150 mm	$\varnothing$ 150 mm	$\varnothing$ 150 mm	$\varnothing$ 150 mm
centre width	550 mm	550 mm	550 mm	550 mm
centre height	125 mm	125 mm	125 mm	125 mm
spindle bore	$\varnothing$ 26 mm	$\varnothing$ 26 mm	$\varnothing$ 26 mm	$\varnothing$ 26 mm
spindle taper	MT 4	MT 4	MT 4	MT 4
3-jaw chuck	$\varnothing$ 125 mm	$\varnothing$ 125 mm	$\varnothing$ 125 mm	$\varnothing$ 125 mm
spindle speed	125 - 2.000 min <sup>-1</sup>	30 - 2.250 min <sup>-1</sup>	125 - 2.000 min <sup>-1</sup>	30 - 2.250 min <sup>-1</sup>
top slide - travel	75 mm	75 mm	70 mm	70 mm
compound slide - travel	120 mm	120 mm	110 mm	110 mm
pitch - metric	0,2 - 3,5 mm / rev	0,2 - 3,5 mm / rev	0,2 - 3,5 mm / rev	0,2 - 3,5 mm / rev
pitch - inch	8 - 56 Gg/1"	8 - 56 Gg/1"	8 - 56 Gg/1"	8 - 56 Gg/1"
speeds	-	stepless	-	stepless
tailstock sleeve travel	70 mm	70 mm	70 mm	70 mm
tailstock taper absorption	MT 2	MT 2	MT 2	MT 2
motor power	0,55 kW - 230 V / 50 Hz	0,85 kW - 230 V / 50 Hz	0,55 kW - 230 V / 50 Hz	0,85 kW - 230 V / 50 Hz
dimensions (L x D x H)	1.110 x 500 x 500 mm	1.110 x 500 x 500 mm	1.110 x 500 x 500 mm	1.110 x 500 x 500 mm
weight	140 kg	140 kg	140 kg	140 kg

	TD 2406	TD 2406 VARIO	TD 2506	TD 2506 VARIO
<b>EAN</b>	4260364295818	4260364295825	4260364295832	4260364295849
<b>Item No.</b>	246 2406	246 2416	246 2506	246 2516



## TD 2807 / TD 2807 VARIO STEPLESS LATHE MACHINES

**THE ORIGINAL  
Epple Maschinen®**



PIC: TD 2807 VARIO  
WITH OPTIONAL STAND

### TD 2807 / TD 2807 VARIO

- » series in a modern design
- » stepless speed adjustment and digital speed display
- » hardened spindle nose
- » true running accuracy < 0,015 mm measured in the spindle nose
- » wide bed, inductively hardened
- » longitudinal feed (TU 2807 (Vario))
- » lead screw cover for a long lifespan
- » emergency stop with undervoltage release
- » standard with right/left rotation switch
- » handwheels with fine scaling
- » speed depending on belt position

### INCLUDED

- » **3-jaw chuck 125 mm**
- » 2 solid tips
- » operating tool
- » chip tray
- » splashback
- » 4-fold steel holder
- » change gear set
- » lathe chuck protection

Description	TD 2807	TD 2807 VARIO
turning- Ø over machine bed	Ø 280 mm	Ø 290 mm
turning-Ø over compound sleds	Ø 170 mm	Ø 175 mm
centre width	700 mm	700 mm
centre height	140 mm	145 mm
spindle bore	Ø 26 mm	Ø 26 mm
spindle taper	MT 4	MT 4
3-jaw chuck	Ø 125 mm	Ø 125 mm
spindle speed	150 - 2.000 min <sup>-1</sup>	150 - 2.000 min <sup>-1</sup>
top slide - travel	60 mm	60 mm
compound slide - travel	160 mm	160 mm
pitch - metric	0,2 - 3,5 mm / rev	0,2 - 3,5 mm / rev
pitch - inch	8 - 56 Gg/1"	8 - 56 Gg/1"
pinole diameter	-	stepless
tailstock sleeve travel	105 mm	105 mm
tailstock taper absorption	MT 2	MT 2
motor power	0,85 kW - 230 V / 50 Hz	1,1 kW - 230 V / 50 Hz
dimensions (L x D x H)	1.220 x 660 x 560 mm	1.220 x 660 x 560 mm
weight	202 kg	210 kg

	TD 2807	TD 2807 VARIO
<b>EAN</b>	<b>4260364295832</b>	<b>4260364295849</b>
<b>Item No.</b>	<b>246 2506</b>	<b>246 2516</b>

# TD 3018 / TD 3018 VARIO

## STEPLESS LATHE MACHINES

THE ORIGINAL  
Epple Maschinen®



PIC: TD 3018 VARIO  
WITH OPTIONAL STAND

### TD 3018 / TD 3018 VARIO

- » stable construction of the machine body made of grey cast iron
- » hardened and ground bed guides
- » guides with adjustable wedge strips
- » automatic longitudinal / cross feeds
- » guide and feed spindle with plain bearings made of sintered metal
- » guide and feed spindle with chip protection coating
- » clockwise / anticlockwise rotation switchable
- » guaranteed true running accuracy less than 0.015 mm measured in the spindle nose
- » adjustable tailstock for taper turning
- » hand wheels with adjustable fine scaling incl. 4-fold tool holder for tools up to 18×18mm
- » speed dependent on belt position (TD 3018)

#### INCLUDED

- » **3-jaw chuck 160 mm**
- » 2 solid tips
- » operating tool
- » chip tray
- » splashback
- » 4-fold steel holder
- » change gear set

Description	TD 3018	TD 3018 VARIO
turning- Ø over machine bed	Ø 300 mm	Ø 300 mm
turning-Ø over compound sleds	Ø 180 mm	Ø 180 mm
centre width	720 mm	800 mm
centre height	158 mm	158 mm
spindle bore	Ø 36 mm	Ø 36 mm
spindle taper	MT 5	MT 5
3-jaw chuck	Ø 160 mm	Ø 160 mm
spindle speed	150 - 2.000 min <sup>-1</sup>	150 - 2.000 min <sup>-1</sup>
top slide - travel	65 mm	65 mm
compound slide - travel	180 mm	180 mm
pitch - metric	0,2 - 3,5 mm / rev	0,2 - 3,5 mm / rev
pitch - inch	8 - 56 Gg/1"	8 - 56 Gg/1"
pinole diameter	-	stepless
tailstock sleeve travel	70 mm	70 mm
tailstock taper absorption	MT 3	MT 3
motor power	400 V / 1,5 kW	400 V / 1,5 kW
dimensions (L x D x H)	1.420 x 705 x 575 mm	1.420 x 705 x 575 mm
weight	260 kg	260 kg

	TD 3018	TD 3018 VARIO
<b>EAN</b>	<b>4260364295870</b>	<b>4260364295887</b>
<b>Item No.</b>	<b>246 3008</b>	<b>246 3018</b>

DRILLING

MILLING

TURNING

SAWING

GRINDING

BENDING

CUTTING /  
PRESSING

OTHER  
MACHINES

ACCESSORIES

# TD 3209 VARIO / TD 3209 VARIO DIGI

## STEPLESS LATHE MACHINES

**NEW**



PIC: TD 3209 VARIO WITH OPTIONAL BASE

### TD 3209 VARIO / TD 3209 VARIO DIGI

- » stable construction of the machine body made of grey cast iron
- » precision lathe with variable speed speed through inverter drive
- » extremely quiet, vibration-free operation
- » large 38 mm spindle bore with D1-4 spindle nose
- » overload clutch to feed shaft, micro stop is available
- » dedicated feed shaft for longitudinal and transverse cross feed
- » H/L gearboxes allow maximum torque at lower speeds
- » hardened and ground bed guideways
- » right/left rotation switchable on the control panel
- » adjustable tailstock for turning tapers
- » handwheels with adjustable fine scaling

### INCLUDED

- » **3-jaw chuck, diameter 160 mm**
- » 2 centering points
- » splash protection wall at the back and bottom
- » chip tray
- » thread dial indicator
- » flexible LED machine light
- » 4-way indexing toolpost
- » operating tools
- » TD 3209 Vario Digi: clear and user-friendly digital LED display

### OPTIONAL EQUIPMENT

- » **quick change tool holder**
- » 4-jaw chuck, diameter 200 mm
- » levelling feet M12
- » coolant device
- » turning steel assortment 16 mm with inserts
- » base

Discription	TD 3209 Vario / TD 3209 Vario DIGI
circumferential Ø over machine bed	Ø 320 mm
swing Ø over support	Ø 200 mm
centre height	180 mm
centre width	880 mm
spindle nose	D 1-4
spindle hole	Ø 38 mm
spindle taper	MT 5
tailstock taper	MT 3
3-jaw chuck, diameter	Ø 160 mm
speeds	75 – 435 / 400 – 2250 min <sup>-1</sup>
top slide - travel	80 mm
compound slide - travel	165 mm
longitudinal feed	0,07 - 0,52 mm/U
cross feed	0,017 - 0,25 mm/U
metric - thread	0,2 - 3,5 mm/U
inch - thread	8-56 Gg/1"
quill - travel	80 mm
motor power	400 V / 1,5 kW
dimensions (L x D x H)	1.600 x 750 x 700 mm
weight	350 kg / 360 kg
	<b>TD 3209 Vario / TD 3209 Vario DIGI</b>
<b>EAN</b>	<b>4260657652083 / 4260657652090</b>
<b>Item No.</b>	<b>246 3209 / 246 3210</b>



Frequency motor drive Fast shifting gears



Safety cover of the upper support

You can find detailed accessories on page 289.

# MD 300-910 / MD 300-910 DIGI

## PRECISION GEARED LATHE MACHINE



PIC: MD 300-910

### MD 300-900 / MD 300-910 DIGI IDEAL FOR EVERY WORKSHOP AND CRAFTSMEN

- » hardened and precisely ground guideways
- » camlock spindle holder D 1-4"
- » precision gearbox lathe running in oil bath - gear drive feed shaft, lead shaft and stem
- » smooth running by hardened and precision-ground gear, running in precision bearings in oil bath
- » smooth-running gear shaft, running in oil bath
- » the running accuracy of the spindle nose < 0,015 mm
- » emergency stop and motor protection
- » cover for leading spindle
- » instep protector at the top slide
- » apron wheels running in oil bath
- » main spindle with D 1-4" absorption, spindle bore 38 mm, held by 2 adjustable with precision tapered roller bearings
- » smooth running main spindle gearwheels
- » slide guideways with adjustable V-ledges
- » stabile, heavy ripped prismatic bed, double prism guide, bed out of grey iron
- » neoprene strips to protect the guideways
- » right and left rotation shift able at the lathe slide by stem

### OPTIONAL ACCESSORIES

- » leveling feet M12
- » coolant emulsion
- » turning tool 12 mm
- » **quick change tool holder Multifix "A" (5-pcs.)**

Description	MD 300-910	MD 300-910 DIGI
centre width	900 mm	900 mm
centre height	165 mm	165 mm
max swing in gap	215 mm	215 mm
spindle hole	38 mm	38 mm
spindle taper	MT 5	MT 5
tailstock taper	MT 3	MT 3
speeds	18	18
speed	65 - 1.810 min <sup>-1</sup>	65 - 1.810 min <sup>-1</sup>
longitudinal feed	0,053 - 1,291 mm/rev	0,053 - 1,291 mm/rev
cross feed	0,011 - 0,276 mm/rev	0,011 - 0,276 mm/rev
metric - thread	0,4 - 7 mm	0,4 - 7 mm
inch - thread	4 - 60 Gg/1"	4 - 60 Gg/1"
top slide - travel	85 mm	85 mm
compound slide - travel	150 mm	150 mm
3-jaw chuck, diameter	160 mm	160 mm
4-jaw chuck, diameter	200 mm	200 mm
face plate, diameter	255 mm	255 mm
motor power	400 V / 1,5 kW	400 V / 1,5 kW
dimensions (L x D x H)	1.550 x 630 x 570 mm	1.550 x 630 x 800 mm
dimensions with stand (L x L x H)	1.550 x 630 x 1.270 mm	1.550 x 630 x 1.500 mm
weight	450 kg	460 kg
	<b>MD 300-910</b>	<b>MD 300-910 DIGI</b>
<b>EAN</b>	<b>4260364290394</b>	<b>4260364290400</b>
<b>Item No.</b>	<b>245 0300</b>	<b>245 1300</b>

### INCLUDED

- » digital readout model MD 300-910 DIGI
- » flexible LED machine light
- » coolant system
- » **3-jaw chuck, diameter 160 mm**
- » **4-jaw chuck, diameter 200 mm,** jaws individually adjustable
- » clamping disk (face plate)
- » fixed steady rest
- » travelling steady rest
- » thread dial indicator
- » 2 centering points
- » chip tray
- » splash protection wall at the back and bottom
- » rear splash guard
- » operating tools
- » foot brake
- » substructure
- » removable bridge
- » electrically pulse button
- » jaw chuck with security switch
- » 4-way indexing toolpost
- » changewheels

INCL. LED LIGHTNING,  
COOLANT SYSTEM

# MD 360-1.000 / MD 360-1.000 DIGI MD 360-1.000 S DIGI

## PRECISION LATHE MACHINES



PIC: MD 360-1.000 DIGI

Description	MD 360-1.000	MD 360-1.000 DIGI	MD 360-1.000 S DIGI
centre width	1.000 mm	1.000 mm	1.000 mm
centre height	180 mm	180 mm	180 mm
max swing in gap	280 mm	280 mm	280 mm
spindle hole	38 mm	38 mm	38 mm
spindle taper	MT 5	MT 5	MT 5
tailstock taper	MT 4	MT 4	MT 4
speeds	16	16	stepless
speed	45 - 1.800 min <sup>-1</sup>	45 - 1.800 min <sup>-1</sup>	40 - 400 min <sup>-1</sup> 220 - 1.800 min <sup>-1</sup>
longitudinal feed	0,043 - 0,653 mm/rev	0,043 - 0,653 mm/rev	0,043 - 0,653 mm/rev
cross feed	0,015 - 0,211 mm/rev	0,015 - 0,211 mm/rev	0,015 - 0,211 mm/rev
metric - thread	0,4 - 7 mm/rev	0,4 - 7 mm/rev	0,4 - 7 mm/rev
inch - thread	4 - 70 TPI	4 - 70 TPI	4 - 70 TPI
diametric threads	8 - 144 D.P.	8 - 144 D.P.	8 - 144 D.P.
module threads	0,25 - 3,5 mm	0,25 - 3,5 mm	0,25 - 3,5 mm
top slide - travel	95 mm	95 mm	95 mm
compound slide - travel	180 mm	180 mm	180 mm
3-jaw chuck, diameter	200 mm	200 mm	160 mm
4-jaw chuck, diameter	200 mm	200 mm	200 mm
face plate, diameter	250 mm	250 mm	250 mm
motor power	400 V / 1,5 kW / 2,4 kW	400 V / 1,5 kW / 2,4 kW	400 V / 4,5 kW
dimensions with stand (L x D x H)	1.920 x 750 x 1.500 mm	1.920 x 750 x 1.800 mm	1.920 x 750 x 1.800 mm
weight	700 kg	710 kg	730 kg
	<b>MD 360-1.000</b>	<b>MD 360-1.000 DIGI</b>	<b>MD 360-1.000 S DIGI</b>
<b>EAN</b>	<b>4260364290417</b>	<b>4260364290424</b>	<b>4260364290431</b>
<b>Item No.</b>	<b>245 0180</b>	<b>245 1180</b>	<b>245 2180</b>



**MD 360-1.000 / MD 360-1.000 DIGI /  
MD 360-1.000 S DIGI**

Ideally suited for production, workshops, repair shops, training and apprentice workshops. The machine MD 360-1.000 Digi has a 3-axis digital display. Modern, high quality precision gear lathe, with induction hardened bed.

- » hardened and precise ground guideways
- » camlock spindle socket D 1-5"



PIC: DIGITAL READOUT SYSTEM

- » smooth running by hardened and precision-ground gear, hardened and grounded gearwheels and shafts, running in precision bearings in oil bath
- » smooth-running gearshift, running in oil bath
- » spindle nose runout < 0,015 mm
- » changewheels in lock case running in oil bath
- » main spindle with camlock D 1-5", spindle bore 38 mm with 2 high precision adjustable precision tapered bearings
- » smooth running main spindle gear wheel
- » slide guideways with adjustable V-ledges
- » stabile, heavy ripped prismatic bed, double prism guide, bed out of grey iron, hardened and grounded
- » scrapers to protect the guideways
- » right and left rotation shift able at the lathe slide by stem
- » emergency stop, lockable main switch and motor protection
- » lead screw protection
- » halogen working light
- » mechanical foot brake
- » control report
- » **model: MD 360-1.000 S DIGI with variable speed adjustment**
- » manufactured according to DIN 8606

**OPTIONAL EQUIPMENT**

- » **quick change toolpost "type B" (5-pcs.)**
- » machine feet M12
- » coolant emulsion
- » turning tool assortment 16 mm with inserts

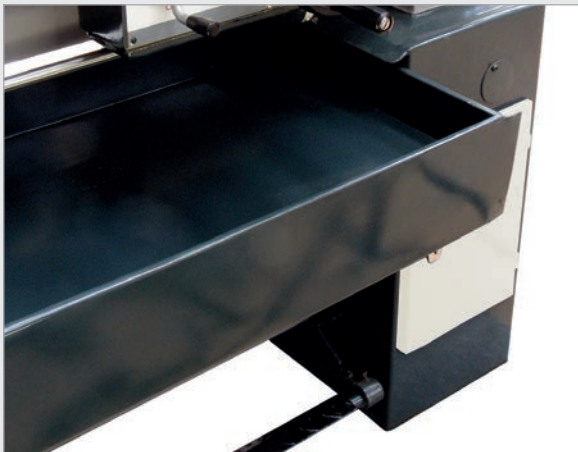

**INCLUDED**

- » digital readout (MD 360-1.000 Digi and MD 360-1.000 S Digi)
- » coolant system
- » halogen work light
- » installed machine base
- » installed splash guards
- » change gear set
- » removeable bridge
- » foot brake
- » jaw chuck shelter with safety switch
- » 3-jaw chuck 200 mm, central clamping
- » 4 jaw chuck 200 mm, individually adjustable jaws
- » face plate Ø 300 mm
- » fixed steady rest
- » travelling steady rest
- » threading gauge for multi blade thread
- » fixing center point MT 4, rotating center point MT 4, adapter sleeve MT 5 to MT 4
- » 4-fold steel holder
- » operating tool

You can find detailed accessories on page 289.

# TD 4210 / TD 4210 DIGI

## HEAVY DUTY CENTRE LATHE MACHINE

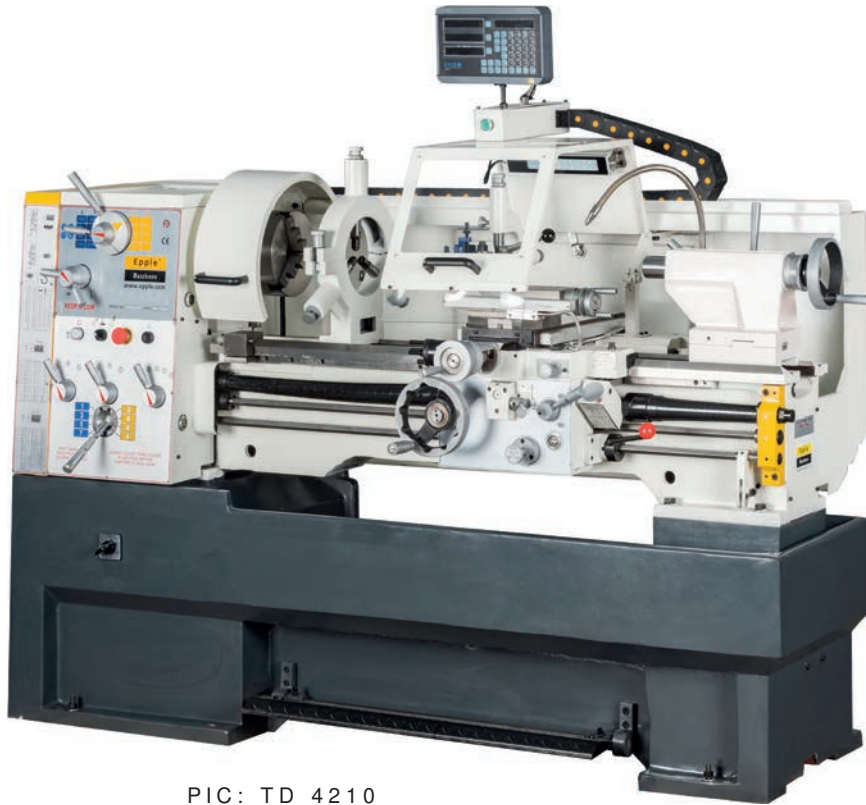

PIC: TD 4210

Heavy Duty Centre Lathe Machines

Description	TD 4210	TD 4210 DIGI
centre width	1.000 mm	1.000 mm
centre height	205 mm	205 mm
max swing in gap	580 mm	580 mm
spindle hole	52 mm	52 mm
spindle taper	MT 6	MT 6
tailstock taper	MT 4	MT 4
speeds	16	16
speed	45 - 1.800 min <sup>-1</sup>	45 - 1.800 min <sup>-1</sup>
longitudinal feed	0,05 - 1,7 mm/rev	0,05 - 1,7 mm/rev
cross feed	0,025 - 0,85 mm/rev	0,025 - 0,85 mm/rev
metric - thread	0,2 - 14 mm/rev	0,2 - 14 mm/rev
inch - thread	2 - 72 Gg/1"	2 - 72 Gg/1"
diametric thread	8 - 44 D.P.	8 - 44 D.P.
module thread	0,3 - 3,5 mm	0,3 - 3,5 mm
top slide - travel	140 mm	140 mm
compound slide - travel	210 mm	210 mm
3-jaw chuck, diameter	200 mm	200 mm
4-jaw chuck, diameter	300 mm	300 mm
face plate, diameter	300 mm	300 mm
motor power	400 V / 4,5 kW	400 V / 4,5 kW
dimensions with stand (L x D x H)	2.025 x 915 x 1.375 mm	2.025 x 915 x 1.375 mm
weight	1.300 kg	1.310 kg
	<b>TD 4210</b>	<b>TD 4210 DIGI</b>
<b>EAN</b>	<b>4260364295894</b>	<b>4260364295900</b>
<b>Item No.</b>	<b>245 0421</b>	<b>245 2420</b>

### INCLUDED

- » **3-jaw chuck 200 mm**
- » **quick-change toolpost "type B" mounted (5-pcs.)**
- » **4-jaw chuck 300 mm,**  
jaws individually adjustable
- » **faceplate 350 mm**
- » **reducing sleeve MT 6 / MT 4**
- » **2 fixing centres MT 4**
- » **steady and follow rest**
- » **spindle brake**
- » **coolant system with dosage**
- » **LED work light**
- » **machine base**
- » **splash guard**
- » **chuck guard with safety switch**
- » **thread clock**
- » **set of changewheels**
- » **operation tools**

**TD 4210 / TD 4210 DIGI**

- » strong and warp resistant construction of the stand and machine bed, made of one piece from cast iron, vibration-absorbing
- » 2-step-motor
- » hardened and ground bed slideways
- » large dimensioned machine bed
- » all guides are provided with adjustable wedge strips
- » central lubrication in bed slide
- » right / left rotation shiftable at bed slide
- » detachable bed insert for machining of large work pieces
- » adjustable tailstock for taper turning
- » accurate spindle runout < 0,015 mm at spindle nose
- » closed feed gear
- » gear wheels and shafts are hardened and ground
- » clearly arranged control panel with a strong selection levers for speed selection
- » changewheel gears in oil bath with hardened and ground toothed gear wheels
- » hand wheels with adjustable fine scale
- » main spindle hardened and ground, running on taper bearings in oil bath
- » mechanical spindle foot brake
- » lead screw cover
- » control report
- » manufactured according to standard "DIN 8606"









**Incl. Quick Change Tool Holder "type B" mounted (5-pcs.)**

**OPTIONAL ACCESSORIES**

- » machine feet M16 industrial version
- » coolant emulsion



PIC: DRO OF TU 4210 DIGI

Description	Item No.	Description	Item No.
 Turning Tool 10 mm	545 0210	 Turning Tool 16 mm	545 2216
 Turning Tool 12 mm	545 0212	 Transmission oil AR 150	580 1150
 Turning Tool 10 mm	545 1210	 Coolant emulsion 5 litres	580 1030
 Turning Tool 12 mm	545 1212	 Life Center	-
 Turning Tool 12 mm	545 2212		

DRILLING

MILLING

TURNING

SAWING

GRINDING

BENDING

CUTTING / PRESSING

OTHER MACHINES

ACCESSORIES

**TD 4610 / TD 4610 DIGI**  
**TD 4615 / TD 4615 DIGI**

**HEAVY DUTY CENTRE LATHE MACHINES**



PIC: TD 4615 DIGI

Description	TD 4610	TD 4610 DIGI	TD 4615	TD 4615 DIGI
centre width	1.000 mm	1.000 mm	1.500 mm	1.500 mm
centre height	230 mm	230 mm	230 mm	230 mm
max swing in gap	690 mm	690 mm	690 mm	690 mm
max swing over support	285 mm	285 mm	285 mm	285 mm
spindle hole	58 mm	58 mm	58 mm	58 mm
tailstock taper	MT 4	MT 4	MT 4	MT 4
spindle absorption (Camlock)	1 - 6"	1 - 6"	1 - 6"	1 - 6"
speeds	12	12	12	12
speed	25 - 2.000 min <sup>-1</sup>	25 - 2.000 min <sup>-1</sup>	25 - 2.000 min <sup>-1</sup>	25 - 2.000 min <sup>-1</sup>
longitudinal feed	0,031 - 1,7 mm/rev	0,031 - 1,7 mm/rev	0,031 - 1,7 mm/rev	0,031 - 1,7 mm/rev
cross feed	0,014 - 0,784 mm/rev	0,014 - 0,784 mm/rev	0,014 - 0,784 mm/rev	0,014 - 0,784 mm/rev
metric - thread	0,1 - 14 mm/rev	0,1 - 14 mm/rev	0,1 - 14 mm/rev	0,1 - 14 mm/rev
inch - thread	2 - 112 Gg/1"	2 - 112 Gg/1"	2 - 112 Gg/1"	2 - 112 Gg/1"
diametric threads	8 - 144 D.P.	8 - 144 D.P.	8 - 144 D.P.	8 - 144 D.P.
module threads	0,25 - 3,5 mm	0,25 - 3,5 mm	0,25 - 3,5 mm	0,25 - 3,5 mm
top slide - travel	128 mm	128 mm	128 mm	128 mm
compound slide - travel	285 mm	285 mm	285 mm	285 mm
3-jaw chuck, diameter	250 mm	250 mm	250 mm	250 mm
4-jaw chuck, diameter	300 mm with individually adjustable jaws	300 mm with individually adjustable jaws	300 mm with individually adjustable jaws	300 mm with individually adjustable jaws
motor power	400 V / 5,5 kW	400 V / 5,5 kW	400 V / 5,5 kW	400 V / 5,5 kW
dimensions with stand (L x D x H)	2.220 x 1.080 x 1.370 mm	2.220 x 1.080 x 1.600 mm	2.720 x 1.080 x 1.370 mm	2.720 x 1.080 x 1.600 mm
weight	1.670 kg	1.680 kg	2.070 kg	2.080 kg
	<b>TD 4610</b>	<b>TD 4610 DIGI</b>	<b>TD 4615</b>	<b>TD 4615 DIGI</b>
<b>EAN new design</b>	<b>4260364295917</b>	<b>4260364295924</b>	<b>4260364295931</b>	<b>4260364295948</b>
<b>Item No. new design</b>	<b>245 0462</b>	<b>245 2460</b>	<b>245 0463</b>	<b>245 2465</b>

**TD 4610 / TD 4610 DIGI**  
**TD 4615 / TD 4615 DIGI**

Center lathe in heavy-duty design with extensive standard accessories. Low vibration and smooth running. Including solid base and machine bed.

- » strong and warp resistant construction of the stand and machine bed, made of one-piece vibration free cast iron
- » hardened and ground bed slideway
- » large dimensioned machine bed
- » guideways have adjustable V-ledges
- » central lubrication in bed slide
- » right / left spindle rotation shiftable at bed slide
- » detachable bed insert for machining of large work piece diameters
- » adjustable tailstock for producing tapers
- » accurate spindle runout < 0,015 mm at spindle nose
- » enclosed gear feed, gear wheels and shafts hardened and grounded
- » clearly arranged control panel with a strong lever for speed selection
- » oil bath changewheel gears with hardened and ground toothed gear wheels
- » hand wheels with adjustable fine scale
- » main spindle hardened and ground, running on taper bearings in oil bath

- » longitudinal feed, disengageable by 4 adjustable cams
- » mechanical spindle foot brake
- » lead screw cover
- » acceptance report
- » manufactured according to standard "DIN 8606"









**INCLUDED EXTRAS**

- » 3-jaw chuck 250 mm
- » quick-change toolpost "type C" mounted (5-pcs.)
- » 4-jaw chuck 300 mm, jaws individually adjustable
- » face plate 350 mm
- » reducing sleeve MT 6 / MT 4
- » 2 fixing centres MT 4
- » fixed and rotating steady rest
- » spindle brake
- » coolant system
- » LED working light
- » machine stand
- » splash guard
- » chuck guard with safety switch
- » thread clock
- » set of changewheels
- » operation tools



Available with or without DRO.

**Optional Accessories**

Description	Item No.	Description	Item No.
 Quick Change Tool Holder Typ Multifix A	545 2201	 Turning Tool 16 mm	545 2216
 Quick Change Tool Holder Typ Multifix B	545 2202	 Mounting Set	545 1112
 Turning Tool 10 mm	545 0210		
 Turning Tool 12 mm	545 0212		
 Turning Tool 10 mm	545 1210		
 Turning Tool 12 mm	545 1212		
 Turning Tool 12 mm	545 2212		

You can find detailed accessories on page 289.



## TD 5615 DIGI TD 5620 DIGI / TD 5630 DIGI HEAVY DUTY CENTRE LATHE MACHINES



PIC: TD 5615  
NEW DESIGN AT PAGE 70

Description	TU 5615 DIGI	TU 5620 DIGI	TU 5630 DIGI
centre width	1.500 mm	2.000 mm	3.000 mm
centre height	280 mm	280 mm	280 mm
spindle hole	105 mm	105 mm	105 mm
max swing over support	326 mm	326 mm	326 mm
tailstock taper	MT 5	MT 5	MT 5
spindle absorption (Camlock)	1 - 7"	1 - 7"	1 - 7"
speeds	12	12	12
speed	25 - 1.600 min <sup>-1</sup>	25 - 1.600 min <sup>-1</sup>	25 - 1.600 min <sup>-1</sup>
longitudinal feed	0,059 - 1,646 mm/rev	0,059 - 1,646 mm/rev	0,059 - 1,646 mm/rev
cross feed	0,02 - 0,573 mm/rev	0,02 - 0,573 mm/rev	0,02 - 0,573 mm/rev
metric - threads	0,2 - 14 mm/rev	0,2 - 14 mm/rev	0,2 - 14 mm/rev
inch - threads	112 - 2 Gg/1"	112 - 2 Gg/1"	112 - 2 Gg/1"
diametric threads	-	-	-
module threads	-	-	-
top slide - travel	130 mm	130 mm	130 mm
compound slide - travel	325 mm	325 mm	325 mm
3-jaw chuck, diameter	315 mm	315 mm	315 mm
4-jaw chuck, diameter	400 mm with adjustable jaws	400 mm with adjustable jaws	400 mm with adjustable jaws
motor power	400 V / 7,5 kW	400 V / 7,5 kW	400 V / 7,5 kW
dimensions with stand (L x D x H)	2.750 x 1.080 x 1.370 mm	3.250 x 1.080 x 1.600 mm	3.250 x 1.080 x 1.600 mm
weight	2.150 kg	2.290 kg	2.680 kg
	<b>TU 5615 DIGI</b>	<b>TU 5620 DIGI</b>	<b>TU 5630 DIGI</b>
<b>EAN new design</b>	<b>4260364295955</b>	<b>4260364295962</b>	<b>4260364295979</b>
<b>Item No. new design</b>	<b>245 2560</b>	<b>245 2565</b>	<b>245 2562</b>

**TD 5615 DIGI**  
**TD 5620 DIGI / TD 5630 DIGI**

Center lathe in heavy-duty design with extensive standard accessories. Low vibration and smooth running. Including solid base and machine bed.

- » strong and warp resistant construction of the stand and machine bed, made of one-piece vibration free cast iron
- » hardened and ground bed slideway
- » large dimensioned machine bed
- » guideways with adjustable wedge strips
- » central lubrication in bed slide
- » right / left spindle rotation shiftable at bed slide
- » detachable bed insert for machining of large work piece diameters
- » adjustable tailstock for producing tapers
- » accurate spindle runout < 0,015 mm at spindle nose
- » enclosed gear feed, gear wheels and shafts hardened and grounded
- » clearly arranged control panel with a strong lever for speed selection
- » oil bath changewheel gears with hardened and ground toothed gear wheels
- » hand wheels with adjustable fine scale
- » main spindle hardened and ground, running on taper bearings in oil bath

- » longitudinal feed, disengageable by 4 adjustable cams
- » mechanical spindle foot brake
- » lead screw cover
- » acceptance report
- » manufactured according to standard "DIN 8606"

**INCLUDED EXTRAS**

- » 3-jaw chuck 315 mm
- » quick-change toolpost "type C" mounted (5-pcs.)
- » 4-jaw chuck 400 mm, jaws individually adjustable
- » reducing sleeve MT 5 / MT 4
- » 2 fixing centres MT 4
- » steady and follow rest
- » spindle brake
- » coolant system with stopcock
- » LED working light
- » machine stand
- » splash guard
- » chuck guard with safety switch
- » thread clock
- » set of changewheels
- » operation tools









**OPTIONAL ACCESSORIES**

- » lathe jaw chuck in different size
- » quick change tool holder Multifix type C/D



Available with or without DRO.

**Optional Accessories**

Description	Item No.	Description	Item No.
 Quick Change Tool Holder Typ Multifix C	545 2203	 Turning Tool 16 mm	545 2216
 Quick Change Tool Holder Typ Multifix D		 Mounting Set	545 1112
 Turning Tool 10 mm	545 0210		
 Turning Tool 12 mm	545 0212		
 Turning Tool 10 mm	545 1210		
 Turning Tool 12 mm	545 1212		
 Turning Tool 12 mm	545 2212		

You can find detailed accessories on page 289.

## TD 6615 DIGI / TD 6620 DIGI TD 6630 DIGI HEAVY DUTY CENTRE LATHE MACHINES



PIC: TD 6615 DIGI - DIGITAL DISPLAY NOT SHOWN  
DESIGN UPDATE SEE PAGE 70

Description	TU 6615 DIGI	TU 6620 DIGI	TU 6630 DIGI
centre width	1.500 mm	2.000 mm	3.000 mm
centre height	330 mm	330 mm	330 mm
spindle hole	105 mm	105 mm	105 mm
max swing over support	455 mm	455 mm	455 mm
tailstock taper	MT 5	MT 5	MT 5
spindle absorption (Camlock)	1 - 8"	1 - 8"	1 - 8"
speeds	16	16	16
speed	25 - 1.600 min <sup>-1</sup>	25 - 1.600 min <sup>-1</sup>	25 - 1.600 min <sup>-1</sup>
longitudinal feed	0,044 - 1,48 mm/rev	0,044 - 1,48 mm/rev	0,044 - 1,48 mm/rev
cross feed	0,022 - 0,74 mm/rev	0,022 - 0,74 mm/rev	0,022 - 0,74 mm/rev
metric - threads	0,45 - 120 mm/rev	0,1 - 14 mm	0,1 - 14 mm
inch - threads	80 - 7/16 Gg/1"	2 - 112 Gg/1"	2 - 112 Gg/1"
diametric threads	7/8 - 160 D.P.	7/8 - 160 D.P.	7/8 - 160 D.P.
module threads	0,25 - 60 M.P	0,25 - 60 M.P	0,25 - 60 M.P
top slide - travel	130 mm	130 mm	130 mm
compound slide - travel	355 mm	355 mm	355 mm
3-jaw chuck, diameter	315 mm	315 mm	315 mm
4-jaw chuck, diameter	400 mm	400 mm	400 mm
motor power	400 V / 7,5 kW	400 V / 7,5 kW	400 V / 7,5 kW
dimensions with stand (L x D x H)	3.050 x 1.230 x 1.595 mm	3.650 x 1.230 x 1.880 mm	4.650 x 1.230 x 1.880 mm
weight	2.920 kg	2.810 kg	3.650 kg
	<b>TU 6615 DIGI</b>	<b>TU 6620 DIGI</b>	<b>TU 6630 DIGI</b>
<b>EAN new design</b>	<b>4260364295986</b>	<b>4260364295993</b>	<b>4260364296006</b>
<b>Item No. new design</b>	<b>245 2661</b>	<b>245 2662</b>	<b>245 2663</b>

**TD 6615 DIGI / TD 6620 DIGI  
TD 6630 DIGI**

Center lathe in heavy-duty design with extensive standard accessories. Low vibration and smooth running. Including solid base and machine bed.

- » strong and warp resistant construction
- » substructure of vibration-absorbing cast iron
- » hardened and ground bed slideway
- » large dimensioned machine bed
- » guideways with adjustable wedge strips
- » central lubrication in bed slide
- » right / left spindle rotation shiftable at bed slide
- » detachable bed insert for machining of large work piece diameters
- » adjustable tailstock for producing tapers
- » accurate spindle runout < 0,015 mm at spindle nose
- » enclosed gear feed, gear wheels and shafts hardened and grounded
- » clearly arranged control panel with a strong lever for speed selection
- » oil bath changewheel gears with hardened and ground toothed gear wheels
- » hand wheels with adjustable fine scale
- » main spindle hardened and ground, running on taper bearings in oil bath

- » longitudinal feed, disengageable by four adjustable cam
- » mechanical spindle foot brake
- » lead screw cover
- » acceptance report
- » manufactured according to standard "DIN 8606"

**INCLUDED EXTRAS**

- » 3-jaw chuck 315 mm
- » quick-change toolpost "type C" mounted (5-pcs.)
- » 4-jaw chuck 400 mm, jaws individually adjustable
- » reducing sleeve MT 5 / MT 4
- » 2 fixing centres MT 4
- » steady and follow rest
- » spindle brake
- » coolant system
- » LED working light
- » machine stand
- » splash guard
- » chuck guard with safety switch
- » thread clock
- » set of changewheels
- » operation tools









**OPTIONAL ACCESSORIES**

- » lathe jaw chuck in different size
- » quick change tool holder Multifix type C/D



Available with or without DRO.

**Optional Accessories**

Description	Item No.	Description	Item No.
 Quick Change Tool Holder Typ Multifix C	545 2203	 Turning Tool 16 mm	545 2216
 Quick Change Tool Holder Typ Multifix D		 Mounting Set	545 1112
 Turning Tool 10 mm	545 0210		
 Turning Tool 12 mm	545 0212		
 Turning Tool 10 mm	545 1210		
 Turning Tool 12 mm	545 1212		
 Turning Tool 12 mm	545 2212		

You can find detailed accessories on page 289.

## TD 8020 / TD 8030 / TD 8040 HEAVY DUTY CENTRE LATHE MACHINES



PIC: TD 8030

### TD 8020 / TD 8030 / TD 8040

Powerful, robustly center and feed spindle lathes for machining larger parts. Deviating from the usual equipment standard for Epple machines, accessories such as lathe chuck or digital display are additionally offered for this model series according to individual requirements (length or diameter) on request.

#### OPTIONAL ACCESSORIES

» lathe jaw chuck in different size

Description	TD 8020	TD 8030	TD 8040
centre width	2.000 mm	3.000 mm	4.000 mm
centre height	390 mm	390 mm	390 mm
diameter	800 mm	800 mm	800 mm
max swing over support	540 mm	540 mm	540 mm
swing diameter without bridge	1.020 mm	1.020 mm	1.020 mm
bridge width	210 mm	210 mm	210 mm
spindle bore	105 mm	105 mm	105 mm
main shaft	1 - 6"	1 - 6"	1 - 6"
speeds	24	24	24
speeds (2 steps)	16 - 1.400 min <sup>-1</sup>	16 - 1.400 min <sup>-1</sup>	16 - 1.400 min <sup>-1</sup>
feed rates (longitudinal)	64	64	64
feed rates (transverse)	64	64	64
thread feed (metric)	44 (1 - 192 mm/rev)	44 (1 - 192 mm/rev)	44 (1 - 192 mm/rev)
thread feed (inch)	21 (24 - 2 Gg/1")	21 (24 - 2 Gg/1")	21 (24 - 2 Gg/1")
tailstock	MT 5	MT 5	MT 5
motor power	400 V / 7,5 kW	400 V / 7,5 kW	400 V / 7,5 kW
dimension (L x D x H)	3.500 x 1.100 x 1.700 mm	4.650 x 1.100 x 1.700 mm	5.500 x 1.100 x 1.700 mm
weight	3.100 kg	3.900 kg	4.500 kg
	<b>TD 8020</b>	<b>TD 8030</b>	<b>TD 8040</b>
<b>EAN</b>	<b>4260657651406</b>	<b>4260657651413</b>	<b>4260657651420</b>
<b>Item No.</b>	<b>245 2802</b>	<b>245 2803</b>	<b>245 2804</b>



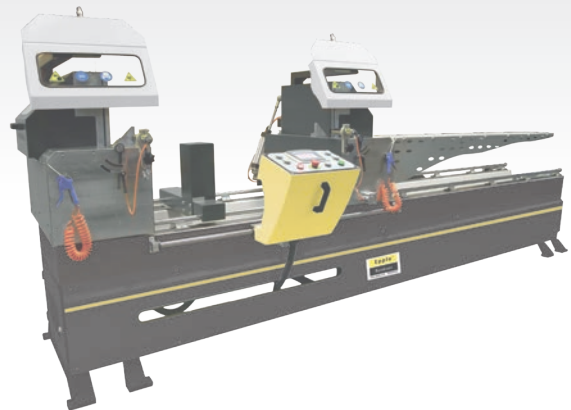
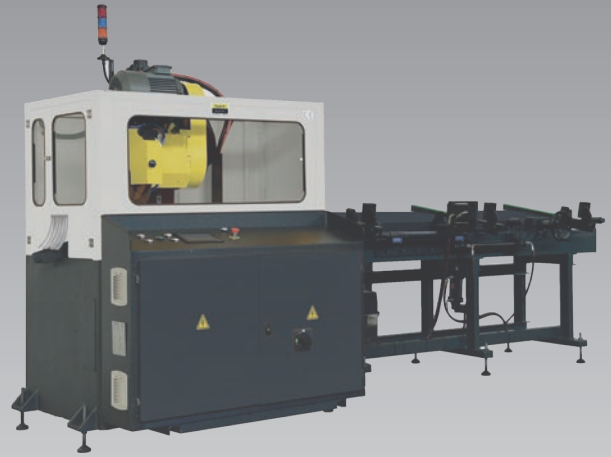

# Sawing

# BS 125 GS

## METAL BAND SAW

THE ORIGINAL  
Epple Maschinen®



### BS 125 GS

- » smooth and vibrationless running
- » ergonomically shaped, comfortable handle
- » transport locking
- » high production quality and performance
- » stepless adjustment of cutting speed
- » swivel saw arm
- » material stop
- » flexible use for horizontal and vertical sawing



Product video-QR on  
www.epple.com

Metal Band Saws

#### Improved construction

With strongly ribbed arm, improved scale, holding bow as well as further improvements.

Vertrieb: Epple, Wiesensteig  
Hotline: 07335 92430  
Internet: www.epple.com

#### Technische Daten:

Spannung: 240 V  
Nennleistung: 1,2 kW  
Abmessungen (H x T x B): 700 x 315 x 740 mm  
Gewicht: 20 kg  
Schnittbereich 90° rund: 120 mm  
Schnittbereich 90° eckig: 130 x 125 mm  
Schnittbereich 45° rund: 70 mm  
Schnittbereich 45° eckig: 70 x 100 mm  
Sägebügelvorschub: Hand  
Bandgeschwindigkeiten: 35 - 80 m/min stufenlos  
Bandabmessungen (L x B x S): 1440 x 13 x 0,65 mm

#### Note:

Funktion: 40% 1,2 ●●●●●  
Bedienung: 40% 1,3 ●●●●●  
Ausstattung: 20% 1,3 ●●●●●

#### Bewertung: + -

➔ Sägeschwindigkeit / Schnittergebnis / Transportfähigkeit

**Handwerk + Industrie**

**Heimwerker  
Praxis** 5/2012

**1,3**

Meisterklasse

Preis/Leistung: gut - sehr gut

Description	BS 125 GS
cutting range 90°	round 125 mm flat 120 x 120 mm rectangular 120 mm
cutting range 45°	round 70 mm flat 120 x 70 mm rectangular 70 mm
cutting range 60°	round 35 mm flat 65 x 35 mm rectangular 35 mm
mitre	45° / 60°
cutting speed	30 - 80 m/min
saw band length	1.440 x 13 x 0,65 mm
motor power	230 V / 50 Hz
dimensions (L x D x H)	740 x 315 x 300 mm
weight	21 kg
	<b>BS 125 GS</b>
EAN	4260364290509
Item No.	230 1125

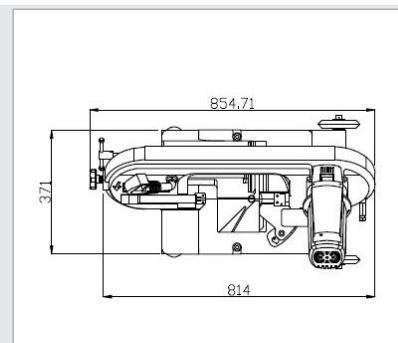
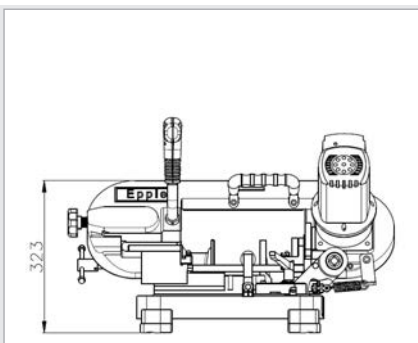
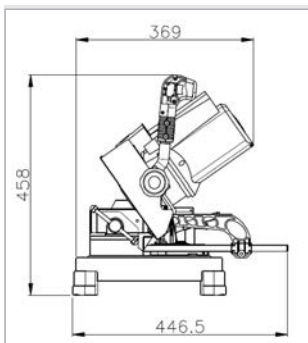

# BS 128 DG

## METAL BAND SAW



### BS 128 DG

- » stepless, hydraulic lowering of the saw bow
- » automatic limit stop
- » manual bandsaw with swivel arm
- » 3 different cutting speeds possible via belt adjustment
- » possible double mitre cutting from -45° to +60°.
- » material dead stop (not pictured)
- » quick - release chuck vice
- » transportable stand and transport handle

Description	BS 128 DG
cutting capacity circular	128 mm
cutting capacity rectangular	128 x 150 mm
cutting range at 45°	round 95 mm, flat 95 x 75 mm
cutting range at 60°	round 44 mm, flat 44 x 56 mm
mitre	von -45° bis +60°
cutting speed	20 / 29 / 50 m/min
saw band length	1.638 x 13 x 0,65 mm
motor power	230 V / 50 Hz / 0,55 kW
inlet height	750 mm
dimensions (L x D x H)	960 x 540 x 610 mm
weight	85 kg
	<b>BS 128 DG</b>
<b>EAN</b>	<b>4260364290516</b>
<b>Item No.</b>	<b>129 0128</b>

You can find detailed accessories on page 289.

# BS 151 GS

## METAL BAND SAW



- BS 151 GS**
- » stepless, hydraulic lowering of the saw bow
  - » manual bandsaw with swivel arm
  - » mitre swivel range until right 60°
  - » material dead stop (not pictured)
  - » manual bandsaw with swivel arm
  - » solid undercarriage for hard daily use included

Description	BS 151 GS
cutting range round	150 mm
cutting range rectangular	150 x 140 mm
mitre	+45° / +60°
mitre cutting circular	90 mm / 65 mm
mitre cutting rectangular	90 x 100 mm / 65 x 70 mm
cutting speed	30 - 80 m/min
saw blade length	1.785 x 13 x 0,9 mm
motor power	230 V / 50 Hz / 1,2 kW
dimensions (L x D x H)	940 x 370 x 1.490 mm
weight	77 kg
<b>BS 151 GS</b>	
<b>EAN</b>	<b>4260364290523</b>
<b>Item No.</b>	<b>230 1151</b>

You can find detailed accessories on page 289.

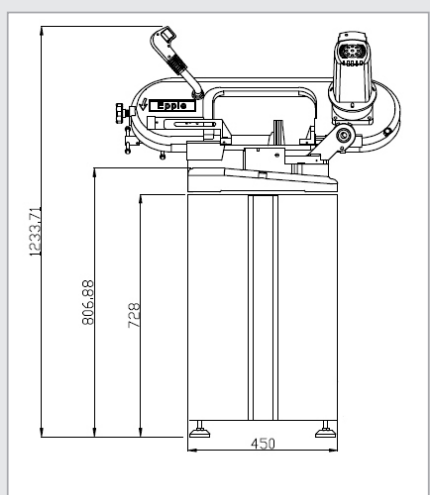
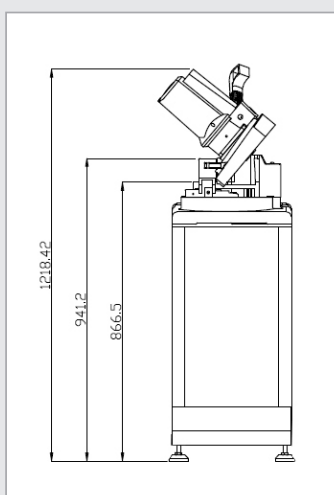
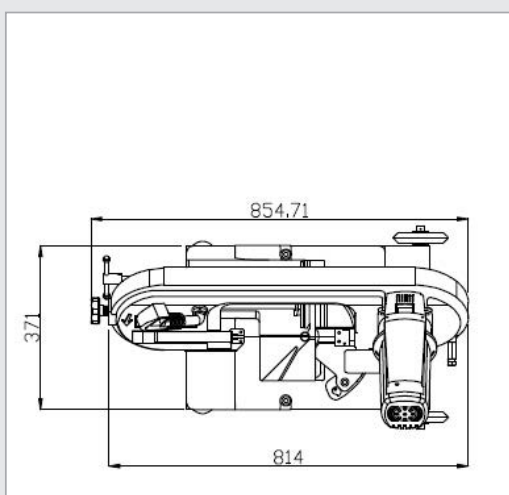

Machine only available without chassis

# BS 180 / BS 180 G

## METAL BAND SAWS



PIC: BS 180 G

### BS 180 / BS 180 G

- » high processing quality and equipment
- » gear in box wheels hardened and ground
- » mitre swivel range up to right 45 °
- » coolant collecting tank and cooling device
- » material stop
- » robust undercarriage for hard everyday use
- » mitre adjustment through angular position of the vice jaws

You can find detailed accessories on page 289.

Description	BS 180	BS 180 G
cutting capacity circular	178 mm	180 mm
cutting capacity rectangular	305 x 178 mm	260 x 180 mm
mitre	+45°	+45°
mitre circular	127 mm	125 mm
mitre cut rectangular vierkant	125 x 120 mm	105 x 120 mm
cutting speed	22 / 34 / 49 / 64 m/min with change belt	39 / 66 / 82 m/min with gear
saw band length	2.360 x 20 x 0,9 mm	2.360 x 20 x 0,9 mm
motor power	400 V / 50 Hz / 0,75 kW	400 V / 50 Hz / 0,75 kW
dimensions (L x D x H)	1.250 x 510 x 1.140 mm	1.300 x 560 x 1.120 mm
weight	140 kg	175 kg
	<b>BS 180</b>	<b>BS 180 G</b>
<b>EAN</b>	4260364296013	4260364296020
<b>Item No.</b>	130 0180	130 1180



# BS 210 G / BS 210 GF

## METAL BAND SAWS



PIC: BS 210 GF

You can find detailed accessories on page 289.

Metal Band Saws

### BS 210 G / BS 210 GF

- » gear with hardened and ground worm shaft
- » 2-speed motor (BS 210 G)
- » stepless speed regulation (BS 210 GF)
- » coolant sump and coolant device
- » stepless cutting speed / frequency converter (BS 210 GF)
- » stepless, hydraulic lowering of the saw bow
- » swivel saw arm
- » automatic limit stop
- » material dead stop
- » quick - release chuck vice
- » control panel
- » thermal fuse and low voltage release
- » material plating
- » robust stand for hard daily insert is included in the scope of supply

Description	BS 210 G	BS 210 GF
cutting capacity circular	170 mm	170 mm
cutting capacity rectangular	190 x 140 mm	200 x 150 mm
mitre	45°	45° / 60°
mitre circular	125 mm	115 mm / 70 mm
mitre cutting rectangular	140 x 95 mm	125 x 110 mm
cutting speed	40 / 80 m/min	30 - 80 m/min
saw band length	2.110 x 20 x 0,9 mm	2.110 x 20 x 0,9 mm
motor power	400 V / 50 Hz / 0,75 kW	400 V / 50 Hz / 0,75 kW
dimensions (L x D x H)	1.200 x 685 x 1.320 mm	1.590 x 630 x 1.730 mm
infeed height	920 mm	920 mm
weight	152 kg	210 kg
	<b>BS 210 G</b>	<b>BS 210 GF</b>
<b>EAN</b>	<b>4260364290530</b>	<b>4260364290547</b>
<b>Item No.</b>	<b>230 0210</b>	<b>230 1210</b>

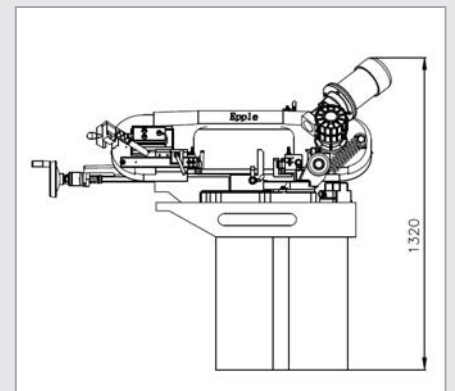
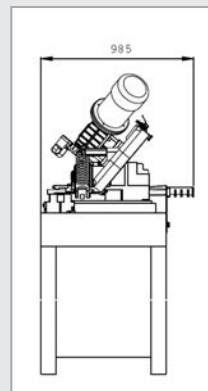
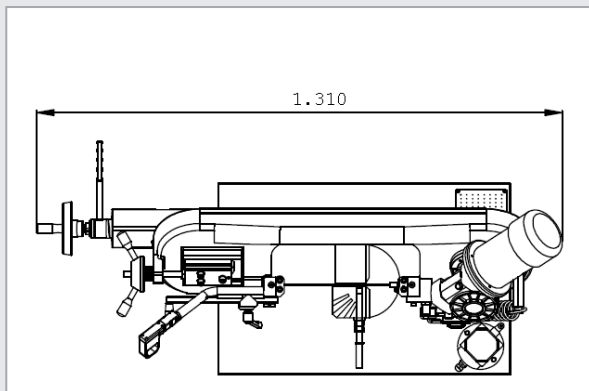

# BS 230 V / BS 230 VG

## METAL BAND SAWS



PIC: BS 230 V



PIC: BS 230 VG  
WITH MITRE SWIVELING  
SAW BOW

### BS 230 V / BS 230 VG

- » smooth and vibrationless running
- » high converting quality and equipment
- » precise cutting - no run of band because of stable cast iron construction and ball bedded 4 point saw band guidance over 4 guidance dual ball bearings
- » gear wheels hardened and ground, running in oil bath
- » variable speed control
- » high electrical safety equipment and with lockable main current caste
- » stepless, hydraulic lowering of the saw bow
- » mitre swiveling saw bow ( BS 230 VG)
- » mitre adjustment for BS 230 V via vice
- » mitre swivel range up to 45° on the right
- » bearing pressure stepless adjustable from 0 to max. with hydraulic cylinder
- » tape tension attachment with scale for an ideal tape tension
- » chip brush
- » automatic limit stop
- » material dead stop
- » cooling liquid tank and coolant system
- » fill level display of cooling liquid case
- » clearly arranged, ergonomic control panel at bow
- » length dead stop
- » robust stand for hard daily insert is included in the scope of supply

Description	BS 230 V	BS 230 VG
cutting range circular	229 mm	229 mm
cutting range rectangular	405 x 127 mm	405 x 127 mm
cutting range at 45° circular	150 mm	150 mm
cutting range at 45° rectangular	190 x 150 mm	190 x 150 mm
speeds	18 - 102 m/min	18 - 102 m/min
blade dimensions	3.215 x 27 x 0,9 mm	3.215 x 27 x 0,9 mm
motor power	400 V / 50 Hz / 1,5 kW	400 V / 50 Hz / 1,5 kW
inlet height	670 mm	670 mm
dimensions (L x D x H)	1.800 x 770 x 1.140 mm	1.880 x 780 x 1.360 mm
weight	300 kg	320 kg
	<b>BS 230 V</b>	<b>BS 230 VG</b>
<b>EAN</b>	<b>4260364290578</b>	<b>4260364290585</b>
<b>Item No.</b>	<b>130 0230</b>	<b>130 1230</b>

# BSP 200

## METAL BAND SAW

**NEW**



### BSP 200

Semi-automatic metal band saw in two-column design for cutting solid material, tubes and profile shapes.

The machine is designed for straight cuts.

The saw bow is guided on two round columns, advantageous for many years of precise saw cuts.

Base body made of stable cast iron, substructure of welded construction. Machine has two speeds for cutting steel and stainless steel.

#### INCLUDED IN DELIVERY

- » hydr. vice
- » coolant system
- » LED machine light
- » saw blade

#### OPTIONAL ACCESSORIES

- » roller conveyor without stop
- » roller conveyor with stop
- » minimum quantity lubrication system
- » replacement saw bands

Description	BSP 200
cutting capacity circular	200 mm
cutting capacity rectangular	200 x 200 mm
cutting speed	28/45 m/min
saw band length	2.650 x 27 x 0,9 mm
motor power	400 V / 50 Hz / 1,3 kW
inlet height	645 mm
dimensions (L x D x H)	1.680 x 970 x 1.300 mm
weight	380 kg
	<b>BSP 200</b>
<b>EAN</b>	<b>4260657650355</b>
<b>Item No.</b>	<b>230 2200</b>

# BS 262 DG

## METAL BAND SAW

**NEW**



### BS 262 DG

- » high quality of workmanship and equipment
- » 10" cutting capacity at 90°
- » saw frame on both sides
- » quick-action vice
- » belt drive, 4 cutting speeds
- » clear, ergonomic control panel
- » mitre swivel range 45/60° without material movement
- » hydraulic feed, with variable speed
- » coolant collecting tray and coolant device
- » material stop
- » robust base frame for tough everyday use
- » mitre adjustment by angular position of the vice jaws

### INCLUDED IN DELIVERY

- » hydr. vice
- » coolant system
- » LED machine light
- » saw blade

Description	BS 262 DG
cutting capacity circular	260 mm
cutting capacity rectangular	260 x 430 mm
mitre cut at 45°	circular 260 mm, rectangular 260 x 130 mm (left) rectangular 300 x 200 mm (right)
mitre cut at 60°	circular 155 mm, rectangular 125 x 125 mm
mitres	from -45° to +60
cutting speed	24 - 109 m/min
saw blade length	3.660 x 27 x 0,9 mm
motor power	230 V / 50 Hz / 1,5 kW
dimensions (L x D x H)	2.120 x 1.080 x 1.220 mm
weight	466 kg
<b>BS 262 DG</b>	
<b>EAN</b>	<b>4260657652106</b>
<b>Item No.</b>	<b>230 0262</b>

DRILLING

MILLING

TURNING

SAWING

GRINDING

BENDING

CUTTING /  
PRESSING

OTHER  
MACHINES

ACCESSORIES



**BS 275 G / BS 275 GS** STEPLESS  
**BS 275 GF** STEPLESS ADJUSTABLE VIA FREQUENCY CONVERTER  
METAL BAND SAWS

Metal Band Saws



PIC: BS 275 G

**BS 275 G /  
BS 275 GS /  
BS 275 GF**



- » gearing with hardened and ground worm gear shaft
- » 2-speed motor (BS 275 G)
- » stepless adjustment of cutting speed (BS 275 GS, BS 275 GF)
- » frequency converter (BS 275 GF)
- » stepless, hydraulic lowering of the saw bow
- » saw bow operable by dint of grab handle
- » mitre swiveling saw bow
- » automatic limit stop
- » material dead stop
- » cooling liquid tank and coolant system
- » coolant system serial with lever tap and plug
- » quick - release chuck vice
- » clearly arranged, ergonomic control panel
- » thermal fuse and low voltage release
- » material plating
- » robust stand for hard daily insert is included in the scope of supply
- » chip brush

You can find detailed accessories on page 289.

Description	BS 275 G	BS 275 GS	BS 275 GF
cutting capacity circular	225 mm	225 mm	225 mm
cutting capacity rectangular	245 x 180 mm	245 x 180 mm	245 x 180 mm
mitre cut at 45°	circular 160 mm, rectangular 160 x 160 mm	circular 160 mm, rectangular 160 x 160 mm	circular 160 mm, rectangular 160 x 160 mm
mitre cut at 60°	circular 100 mm, rectangular 100 x 100 mm	circular 100 mm, rectangular 100 x 100 mm	circular 100 mm, rectangular 100 x 100 mm
mitre	up to 60°	up to 60°	up to 60°
cutting speed	45 - 90 m/min	20 - 90 m/min	20 - 90 m/min
saw band length	2.480 x 27 x 0,9 mm	2.480 x 27 x 0,9 mm	2.480 x 27 x 0,9 mm
motor power	400 V / 50 Hz / 1,1 kW	230 V / 50 Hz / 1,5 kW	400 V / 50 Hz / 1,5 kW
dimensions (L x D x H)	1.380 x 580 x 1.290 mm	1.380 x 580 x 1.290 mm	1.380 x 580 x 1.290 mm
inlet height	910 mm	910 mm	910 mm
weight	210 kg	210 kg	220 kg
	<b>BS 275 G</b>	<b>BS 275 GS</b>	<b>BS 275 GF</b>
<b>EAN</b>	4260364290592	4260364290608	4260364290615
<b>Item No.</b>	230 1275	230 2275	230 3275

**Epple BS 275 G**

Vertrieb: Epple, Wiesensteig  
Preis: um 2.100 Euro  
Hotline: 0 73 35 / 9 24 30  
Internet: www.epple.com

**Technische Daten:**

Spannung: 400 V  
Nennleistung: 1,1 kW  
Gewicht: 225 kg  
Schnittbereich 90° rund: 225 mm  
Schnittbereich 90° eckig: 245 x 150 mm  
Schnittbereich 45° rund: 160 mm  
Schnittbereich 45° eckig: 160 x 160 mm  
Sägebühenvorschub: stufenlose Ölhydraulik  
Bandgeschwindigkeiten: 45 und 90 m/min  
Bandabmessungen (L x B x S): 2080 x 20 x 0,9 mm  
Kühlmittelbehälter: 9 l

**Bewertung:** + -

+ Sägeschwindigkeit  
+ Einstellung Absenkgeschwindigkeit  
+ Kühlmittelrückführung

**Note:**

Handhabung: 40% 1,5 ●●●●●  
Funktion: 40% 1,5 ●●●●●  
Ausstattung: 20% 1,3 ●●●●●

**Meisterklasse**

**Handwerk + Industrie 1,5**

in Heimwerker Praxis Ausgabe 1/2008  
Preis/Leistung: gut



# BS 280 DGS / BS 280 DGF

## METAL BAND SAWS



PIC: BS 280 DGS



clear ergonomic control panel

### BS 280 DGS / BS 280 DGF

- » variable speed control
- » frequency converter (BS 280 DGF)
- » cooling liquid tank and coolant system
- » lowering device saw arm stepless adjustable
- » saw arm swiveling to the right 60° and to the left 45°
- » material dead stop
- » analogue saw band - electric tension display for ideal cutting for protection of the saw band
- » coolant system serial with lever tap and plug
- » quick - release chuck vice
- » clearly arranged, ergonomic control panel
- » robust stand for hard daily insert
- » automatic end switch

You can find detailed accessories on page 289.

Description	BS 280 DGS	BS 280 DGF
cutting capacity circular	225 mm	225 mm
cutting capacity rect.	245 x 150 mm	245 x 150 mm
mitre cut at 45°	circular 150 mm, rectangular 150 x 150 mm	circular 150 mm, rectangular 150 x 150 mm
mitre cut at 60°	circular 85 mm, rectangular 85 x 85 mm	circular 85 mm, rectangular 85 x 85 mm
mitre	from -45° up to +60°	from -45° up to +60°
cutting speed	20 - 90 m/min	20 - 90 m/min
saw band length	2.480 x 27 x 0,9 mm	2.480 x 27 x 0,9 mm
motor power	230 V / 50 Hz / 1,5 kW	400 V / 50 Hz / 1,5 kW
dimensions (L x D x H)	1.380 x 705 x 1.500 mm	1.380 x 705 x 1.500 mm
inlet height	980 mm	980 mm
weight	285 kg	300 kg
	<b>BS 280 DGS</b>	<b>BS 280 DGF</b>
<b>EAN</b>	<b>4260364290622</b>	<b>4260364290639</b>
<b>Item No.</b>	<b>230 1280</b>	<b>230 2280</b>

# BS 300 DGH / BS 300 DGHF

## METAL BAND SAWS

**NEW**



PIC: BS 300 DGH

**Metal Band Saws**

### BS 300 DGH / BS 300 DGHF

- » 2-speed motor ( BS 300 DGH)
- » stepless speed control (BS 300 DGHF)
- » frequency converter (BS 300 DGHF)
- » material stop with scaling
- » lowering device saw arm stepless adjustable
- » saw arm swiveling to the right 60° and to the left 45°
- » analogue saw band - electric tension display
- » with bi-metal saw blade as standard
- » chip brush
- » coolant system serial with lever tap and plug
- » vice with quick adjustment
- » clearly arranged, ergonomic control panel
- » hard metal and ball bearing guides
- » good readable angle scale
- » semi-automatic saw operation and limit stop

Description	BS 300 DGH	BS 300 DGHF
cutting capacity circular	255 mm	255 mm
cutting capacity rect.	320 x 200 mm	320 x 200 mm
mitre cut at +60°	circular 125 mm, rectangular 130 x 120 mm	circular 125 mm, rectangular 130 x 120 mm
mitre cut at +45°	circular 195 mm, rectangular 195 x 195 mm	circular 195 mm, rectangular 195 x 195 mm
mitre cut at -45°	circular 200 mm, rectangular 200 x 170 mm	circular 200 mm, rectangular 200 x 170 mm
mitre	von -45° bis +60°	von -45° bis +60°
cutting speed	35 - 70 m/min	20 - 80 m/min
saw band length	2.750 x 27 x 0,9 mm	2.750 x 27 x 0,9 mm
motor power	400 V / 50 Hz / 1,5 kW	400 V / 50 Hz / 1,5 kW
dimensions (L x D x H)	1.700 x 1.300 x 1.550 mm	1.700 x 1.300 x 1.550 mm
inlet height	950 mm	950 mm
weight	350 kg	350 kg
	<b>BS 300 DGH</b>	<b>BS 300 DGHF</b>
<b>EAN</b>	<b>4260657650362</b>	<b>4260657650379</b>
<b>Item No.</b>	<b>230 2300</b>	<b>230 3300</b>

# BS 350 DG / BS 350 DGH SEMI-AUTOMATIC BS 350 DGHF SEMI-AUTOMATIC WITH FREQUENCY CONVERTER METAL BAND SAWS



PIC: BS 350 DGHF



Rotatable and ergonomic designed control panel



blade tension device

You can find detailed accessories on page 289.

## BS 350 DG / BS 350 DGH / BS 350 DGHF

- » 2-speed motor (BS 350 DG, BS 350 DGH)
- » stepless speed control (BS 350 DGHF)
- » frequency converter (BS 350 DGHF)
- » material dead stop with scale
- » lowering device saw arm stepless adjustable
- » mitre swivel range from left -45° to right 60°
- » analogue saw band-electric tension display for ideal cutting for protection of the saw band
- » serially with bi-metal saw band
- » chip brush
- » material dead stop
- » coolant system with lever tap and plug
- » cooling liquid tank and coolant system
- » hydraulic vice, self-locking (BS 350 DGH / BS 350 DGHF)
- » control panel pivotable
- » clearly arranged, ergonomic control panel
- » hard metal and ball bearing guides
- » good readable angle scale
- » semi-automatic saw operation and limit stop (BS 350 DGH / BS 350 DGHF)

Description	BS 350 DG	BS 350 DGH	BS 350 DGHF
cutting capacity circular	270 mm	270 mm	270 mm
cutting capacity rectangular	350 x 230 mm	350 x 240 mm	350 x 240 mm
mitre cut at +60°	circular 140 mm, rectangular 140 x 140 mm	circular 140 mm, rectangular 140 x 140 mm	circular 140 mm, rectangular 140 x 140 mm
mitre cut at +45°	circular 230 mm, rectangular 230 x 150 mm	circular 230 mm, rectangular 230 x 150 mm	circular 230 mm, rectangular 230 x 150 mm
mitre cut at -45°	circular 200 mm, rectangular 200 x 140 mm	circular 200 mm, rectangular 200 x 140 mm	circular 200 mm, rectangular 200 x 140 mm
mitre	from -45° up to +60°	from -45° up to +60°	from -45° up to +60°
cutting speed	36 - 72 m/min	36 - 72 m/min	36 - 72 m/min
saw band length	2.925 x 27 x 0,9 mm	2.925 x 27 x 0,9 mm	2.925 x 27 x 0,9 mm
motor power	400 V / 50 Hz / 1,9 kW	400 V / 50 Hz / 1,9 kW	400 V / 50 Hz / 1,9 kW
dimensions (L x D x H)	1.765 x 950 x 1.600 mm	1.765 x 950 x 1.600 mm	2.220 x 1.055 x 1.930 mm
inlet height	930 mm	930 mm	930 mm
weight	670 kg	670 kg	700 kg
	<b>BS 350 DG</b>	<b>BS 350 DGH</b>	<b>BS 350 DGHF</b>
<b>EAN</b>	<b>4260364290646</b>	<b>4260364290653</b>	<b>4260364290660</b>
<b>Item No.</b>	<b>230 1350</b>	<b>230 2350</b>	<b>230 3350</b>

# BS 360 DGH / BS 360 DGHF

## METAL BAND SAWS

**NEW**



**Metal Band Saws**

### BS 360 DGH / BS 360 DGHF

- » 2-speed motor ( BS 360 DGH)
- » stepless speed control (BS 360 DGHF)
- » frequency converter (BS 360 DGHF)
- » material stop with scaling
- » lowering device saw arm stepless adjustable
- » saw arm swiveling to the right 60° and to the left 45°
- » analogue saw band - electric tension display
- » with bi-metal saw blade as standard
- » chip brush
- » coolant system serial with lever tap and plug
- » vice with quick adjustment
- » clearly arranged, ergonomic control panel
- » hard metal and ball bearing guides
- » good readable angle scale
- » semi-automatic saw operation and limit stop

Description	BS 360 DGH	BS 360 DGHF
cutting capacity circular	355 mm	355 mm
cutting capacity rect.	530 x 300 mm	530 x 300 mm
mitre cut at +60°	circular 240 mm, rectangular 240 x 170 mm	circular 240 mm, rectangular 240 x 170 mm
mitre cut at +45°	circular 355 mm, rectangular 360 x 290 mm	circular 355 mm, rectangular 360 x 290 mm
mitre cut at -45°	circular 300 mm, rectangular 270 x 270 mm	circular 300 mm, rectangular 270 x 270 mm
mitre	von -45° bis +60°	von -45° bis +60°
cutting speed	20 - 80 m/min	20 - 80 m/min
saw band length	3.770 x 34 x 1,1 mm	3.770 x 34 x 1,1 mm
motor power	400 V / 50 Hz / 2,2 kW	400 V / 50 Hz / 2,2 kW
dimensions (L x D x H)	2.050 x 900 x 1.600 mm	2.050 x 900 x 1.600 mm
inlet height	970 mm	970 mm
weight	660 kg	665 kg
	<b>BS 360 DGH</b>	<b>BS 360 DGHF</b>
<b>EAN</b>	<b>4260657650386</b>	<b>4260657650393</b>
<b>Item No.</b>	<b>230 2360</b>	<b>230 3360</b>

# E-BS 230 DG / E-BS 230 DGH E-BS 230 V

## METAL BAND SAWS

**PREMIUM-LINE**



PIC: E-BS 230 DG

### E-BS 230 DG / E-BS 230 DGH / E-BS 230 V

- » semi-automatic machine (E-BS 230 DGH)
- » quick vice (E-BS 230 DG)
- » hydr. vice (E-BS 230 DGH)
- » vice with material drive rollers for the E-BS 230 V
- » full automatic model (E-BS 230 V)

### OPTIONAL ACCESSORIES

- » stepless cutting speed
- » inverter
- » roller track
- » micro lubrication device

Description	E-BS 230 DG	E-BS 230 DGH	E-BS 230 V
cutting capacity circular	230 mm	230 mm	230 mm
cutting capacity flat	320 x 130 mm	320 x 130 mm	240 x 230 mm
cutting capacity rectangular	230 mm	230 mm	230 mm
mitre cut at 45°	circular 210 mm / 180 mm flat 230 x 160 mm / 230 x 100 mm rectangular 180 mm / 150 mm	circular 210 mm / 180 mm flat 230 x 160 mm / 230 x 160 mm rectangular 180 mm / 150 mm	-
mitre cut at 60°	circular 120 mm flat 120 x 100 mm rectangular 100 mm	circular 120 mm flat 120 x 100 mm rectangular 100 mm	miterless
mitre	up to 60°	up to 60°	-
cutting speed	35 - 70 m/min	35 - 70 m/min	35 - 70 m/min
saw band length	2.730 x 27 x 0,9 mm	2.730 x 27 x 0,9 mm	2.730 x 27 x 0,9 mm
motor power	400 V / 50 Hz / 1,3 kW	400 V / 50 Hz / 1,3 kW	400 V / 50 Hz / 1,3 kW
dimensions (L x D x H)	1.350 x 700 x 1.300 mm	1.350 x 700 x 1.300 mm	1.700 x 800 x 1.500 mm
inlet height	760 mm	760 mm	590 mm
weight	415 kg	465 kg	565 kg
	<b>E-BS 230 DG</b>	<b>E-BS 230 DGH</b>	<b>E-BS 230 V</b>
<b>EAN</b>	<b>4260364290677</b>	<b>4260364290684</b>	<b>4260364296037</b>
<b>Item No.</b>	<b>330 0230</b>	<b>330 1230</b>	<b>330 2230</b>

DRILLING

MILLING

TURNING

SAWING

GRINDING

BENDING

CUTTING /  
PRESSING

OTHER  
MACHINES

ACCESSORIES



# E-BS 270 DG / E-BS 270 DGH

## METAL BAND SAWS

**PREMIUM-LINE**



PIC: E-BS 270 DG

### E-BS 270 DG / E-BS 270 DGH

- » semi-automatic machine (E-BS 270 DGH)
- » micro lube facility (optional)
- » inverter standard = stepless speed adjustment 20 - 100 m/min
- » hydraulic vice (E-BS 270 DGH)

Description	E-BS 270 DG	E-BS 270 DGH
cutting capacity circular	270 mm	270 mm
cutting capacity flat	350 x 220 mm	350 x 220 mm
cutting capacity rectangular	270 mm	270 mm
mitre cut at 45° circular	240 mm / 210 mm	240 mm / 210 mm
mitre cut at 45° flat	270 x 200 mm / 270 x 210 mm	270 x 200 mm / 270 x 210 mm
mitre cut at 45° rectangular	170 mm / 180 mm	170 mm / 180 mm
mitre cut at 60° circular	150 mm	150 mm
mitre cut at 60° flat	150 x 100 mm	150 x 100 mm
mitre cut at 60° rectangular	100 mm	100 mm
mitre	up to 60°	up to 60°
cutting speed	20 - 100 m/min	20 - 100 m/min
saw band length	3.160 x 27 x 0,9 mm	3.160 x 27 x 0,9 mm
motor power	400 V / 50 Hz / 1,5 kW	400 V / 50 Hz / 1,5 kW
dimensions (L x D x H)	1.730 x 770 x 1.460 mm	1.730 x 770 x 1.460 mm
inlet height	910 mm	910 mm
weight	465 kg	525 kg
	<b>E-BS 270 DG</b>	<b>E-BS 270 DGH</b>
<b>EAN</b>	<b>4260364290691</b>	<b>4260364290707</b>
<b>Item No.</b>	<b>330 0270</b>	<b>330 1270</b>

# E-BS 320 H / E-BS 320 V / E-BS 320 DGH METAL BAND SAWS

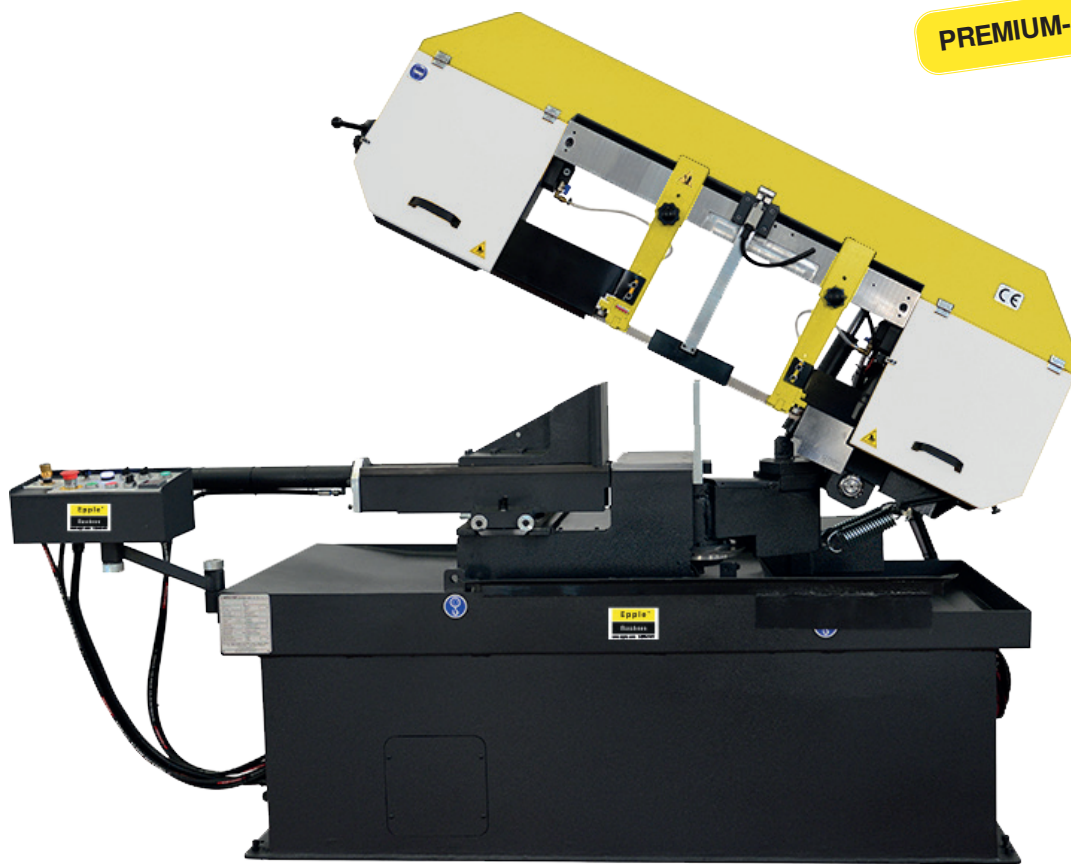

PIC: E-BS 320 DGH

## E-BS 320 - MODELS

- » micro lubrication device
- » mitre adjustment via the clamping jaws  
(only limited recommendation for bar material)
- » inverter for stepless speed control 20 - 100 m/min
- » full automatic model (E-BS 320 V / E-BS 320 VL)
- » semi automatic model (E-BS 320 H / E-BS 320 HL)
- » hydraulic vice

## OPTIONAL ACCESSORIES

- » roller track
- » micro lubrication device
- » servo feed

**NEW**

Description	E-BS 320 H	E-BS 320 V	E-BS 320 DGH
cutting capacity circular	320 mm	320 mm	330 mm
cutting capacity flat	440 x 220 mm	320 x 300 mm	450 x 320 mm
cutting capacity rectangular	320 x 320 mm	300 x 300 mm	320 x 320 mm
mitre cut at 45° circular	280 mm	-	320 mm
flat	280 x 200 mm		340 x 320 mm
rectangular	260 x 260 mm		320 x 320 mm
mitre	up to 45°	-	-45° up to +60°
cutting speed	20 - 100 m/min	20 - 100 m/min	20 - 100 m/min
saw band length	3.660 x 27 x 0,9 mm	3.660 x 27 x 0,9 mm	4.160 x 34 x 1,1 mm
motor power	400 V / 50 Hz / 1,5 kW	400 V / 50 Hz / 2,2 kW	400 V / 50 Hz / 2,2 kW
dimensions (L x D x H)	1.900 x 850 x 1.300 mm	1.900 x 850 x 1.350 mm	2.230 x 880 x 1.890 mm
inlet height	640 mm	640 mm	1.035 mm
weight	670 kg	770 kg	950 kg
	<b>E-BS 320 H</b>	<b>E-BS 320 V</b>	<b>E-BS 320 V</b>
<b>EAN</b>	4260364290721	4260364290738	4260657651437
<b>Item No.</b>	330 1320	330 2320	330 8320

DRILLING

MILLING

TURNING

SAWING

GRINDING

BENDING

CUTTING / PRESSING

OTHER MACHINES

ACCESSORIES

# E-BS 320 HL / E-BS 320 VL

## METAL BAND SAWS

**PREMIUM-LINE**



PIC: E-BS 320 HL

**Metal Band Saws**

### E-BS 320 - MODELS

- » micro lubrication device
- » mitre adjustment via the clamping jaws  
(only limited recommendation for bar material)
- » inverter for stepless speed control 20 - 100 m/min
- » full automatic model (E-BS 320 V / E-BS 320 VL)
- » semi automatic model (E-BS 320 H / E-BS 320 HL)
- » hydraulic vice

### OPTIONAL ACCESSORIES

- » roller track
- » micro lubrication device
- » servo feed

Description	E-BS 320 HL	E-BS 320 VL
cutting capacity circular	330 mm	330 mm
cutting capacity flat	610 x 310 mm	500 x 320 mm
cutting capacity rectangular	330 x 320 mm	320 x 320 mm
mitre cut at 45°	320 mm	-
circular	460 x 180 mm	
flat	320 x 320 mm	
rectangular		
mitre	up to +45°	-
cutting speed	20 - 100 m/min	20 - 100 m/min
saw band length	4.160 x 34 x 1,1 mm	4.160 x 34 x 1,1 mm
motor power	400 V / 50 Hz / 2,2 kW	400 V / 50 Hz / 2,2 kW
dimensions (L x D x H)	2.100 x 850 x 1.300 mm	2.100 x 850 x 1.300 mm
inlet height	640 mm	640 mm
weight	773 kg	860 kg
	<b>E-BS 320 HL</b>	<b>E-BS 320 VL</b>
<b>EAN</b>	<b>4260364290752</b>	<b>4260364290769</b>
<b>Item No.</b>	<b>330 1321</b>	<b>330 2321</b>

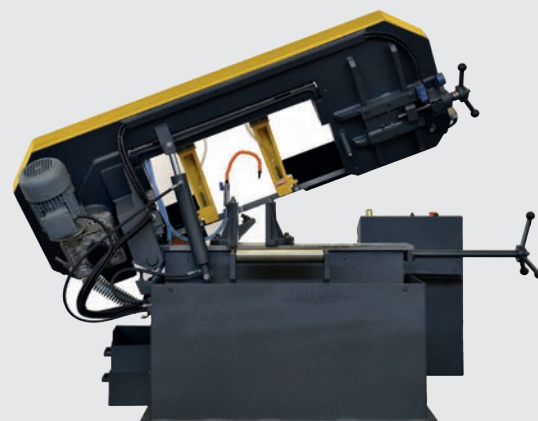

PIC: BACKSIDE

**E-BS 320 GV** PLC FULLY AUTOMATIC  
**E-BS 320 GVL** PLC FULLY AUTOMATIC  
METAL BAND SAWS

**PREMIUM-LINE**

STANDARD



PIC: E-BS 320 GV

Description	E-BS 320 GV	E-BS 320 GVL
cutting capacity	circular 320 mm flat 350 x 320 mm rectangular 320 x 320 mm	circular 320 mm flat 610 x 320 mm rectangular 320 x 320 mm
mitre cut at 30°	circular 160 mm flat 150 x 150 mm rectangular 150 x 150 mm	circular 260 mm flat 280 x 200 mm rectangular 225 x 225 mm
mitre cut at 45°	circular 260 mm flat 250 x 180 mm rectangular 180 x 180 mm	circular 320 mm flat 355 x 320 mm rectangular 320 x 320 mm
mitre cut at 60°	circular 300 mm flat 300 x 200 mm rectangular 250 x 250 mm	circular 320 mm flat 510 x 320 mm rectangular 320 x 320 mm
mitre cut at 75°	circular 320 mm flat 350 x 200 mm rectangular 300 x 300 mm	circular 320 mm flat 580 x 320 mm rectangular 320 x 320 mm
mitre	75°	75°
cutting speed	20 - 100 m/min	20 - 100 m/min
saw band length	3.660 x 27 x 0,9 mm	4.160 x 34 x 1,1 mm
motor power	400 V / 50 Hz / 2,2 kW	400 V / 50 Hz / 2,2 kW
dimensions (L x Dx H)	2.200 x 2.100 x 1.500 mm	2.400 x 2.370 x 1.500 mm
inlet height	740 mm	740 mm
weight	1.660 kg	2.060 kg
	<b>E-BS 320 GV</b>	<b>E-BS 320 GVL</b>
<b>EAN</b>	<b>4260364290776</b>	<b>4260364290783</b>
<b>Item No.</b>	<b>330 3320</b>	<b>330 3321</b>

**E-BS 320 GV / E-BS 320 GVL**

- » fully automatic
- » micro lubrication device
- » inverter for stepless speed control 20 - 100 m/min
- » hydraulic vice
- » digital angle display
- » hydraulic clamping of the saw arm, manual turning of saw arm
- » saw arm swivel up to 60°

OPTIONAL



DRILLING

MILLING

TURNING

SAWING

GRINDING

BENDING

CUTTING / PRESSING

OTHER MACHINES

ACCESSORIES



# E-BSP 325 GH / E-BSP 325 GV

## METAL BAND SAWS

NEW

PREMIUM-LINE



PIC: E-BSP 325 GV

Metal Band Saws

Description	E-BSP 325 GH	E-BSP 325 GV
cutting capacity 0°	circular 325 mm flat 400 x 320 mm rectangular 320 mm	circular 325 mm flat 400 x 315 mm rectangular 315 mm
mitre cut at +30°	circular 325 mm flat 360 x 320 mm rectangular 320 mm	circular 325 mm flat 380 x 315 mm rectangular 315 mm
mitre cut at +45°	circular 305 mm flat 270 x 320 mm rectangular 270 mm	circular 300 mm flat 300 x 315 mm rectangular 300 mm
mitre cut at +60°	circular 190 mm flat 180 x 240 mm rectangular 180 mm	circular 200 mm flat 200 x 315 mm rectangular 200 mm
mitre	up to +60°	up to +60°
cutting speed	20 - 100 m/min	20 - 100 m/min
saw band length	4.380 x 34 x 1,1 mm	4.380 x 34 x 1,1 mm
motor power	400 V / 50 Hz / 2,2 kW	400 V / 50 Hz / 2,2 kW
dimensions (L x D x H)	2.100 x 1.050 x 1.600 mm	2.130 x 2.150 x 1.650 mm
inlet height	640 mm	655 mm
weight	1.185 kg	1.860 kg
	<b>E-BSP 325 GH</b>	<b>E-BSP 325 GV</b>
<b>EAN</b>	4260364296051	4260364290790
<b>Item No.</b>	330 1325	330 2325



## E-BSP 325 GH / E-BSP 325 GV

- » semi-automatic (E-BSP 325 GH)
- » fully-automatic (E-BSP 325 GV)
- » mitre
- » inverter standard = stepless adjustable speed 20 - 100 m/min
- » hydraulic vice
- » digital readout for angle display
- » hydraulic clamping of the saw arm, manual turning of saw arm
- » saw band ilted for 3°
- » due to sensors there is automatic saw speed adjustment
- » saw mill is made of solid steel
- » synchronization of tape guide and vise
- » angular toothed conical heavy-duty gearbox
- » hydraulic vice clamping over the entire clamping range
- » hydromechanical tape tension is readable via manometer
- » mobile control panel
- » high-quality hydraulic components
- » powered chip brush
- » substructure and arm are a heavy welding construction
- » vertical movement with high-precision linear guides

The **E-BSP 325 GH** is a semi-automatic metal band saw in two-column design, which is suitable in the medium cutting range (round up to 325 mm, flat 400 x 320 mm) excellent for cutting solid material as well as tubes, profiles and beams in steel cutting. With this machine 0° and up to 60° one-sided cuts are possible. Precision carbide saw blade guides and a robust, rigid construction of the machine guarantee a precise cut. The basic equipment of this machine includes a full stroke clamping cylinder as well as a continuously adjustable belt Speed. The saw band runs over a large drive and deflection wheel, which ensures the longest possible service life.

### STANDARD

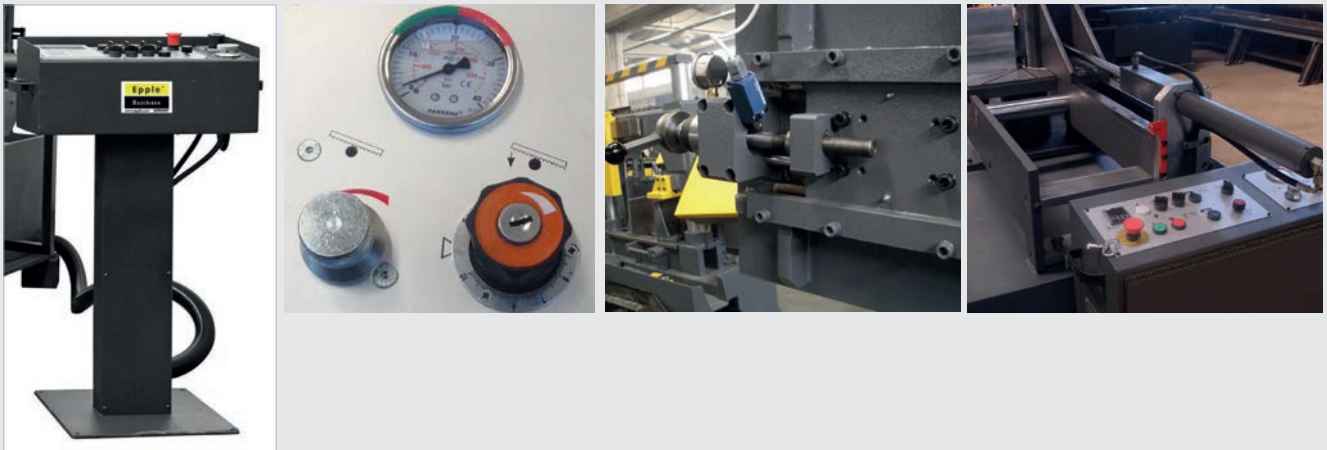

### OPTIONAL

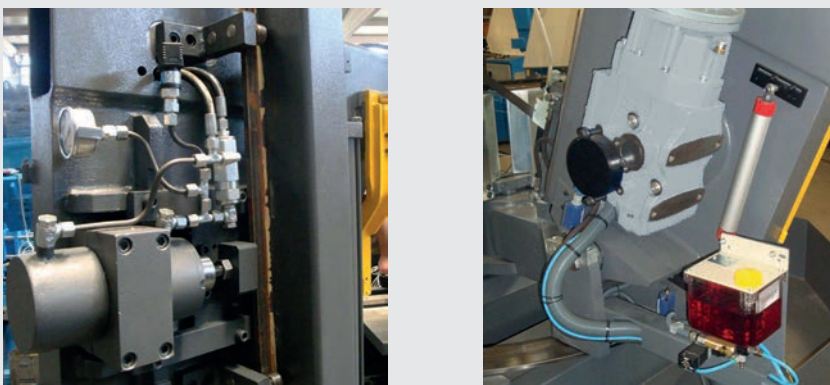

# E-BSP 330 NC

## METAL BAND SAW

**PREMIUM-LINE**

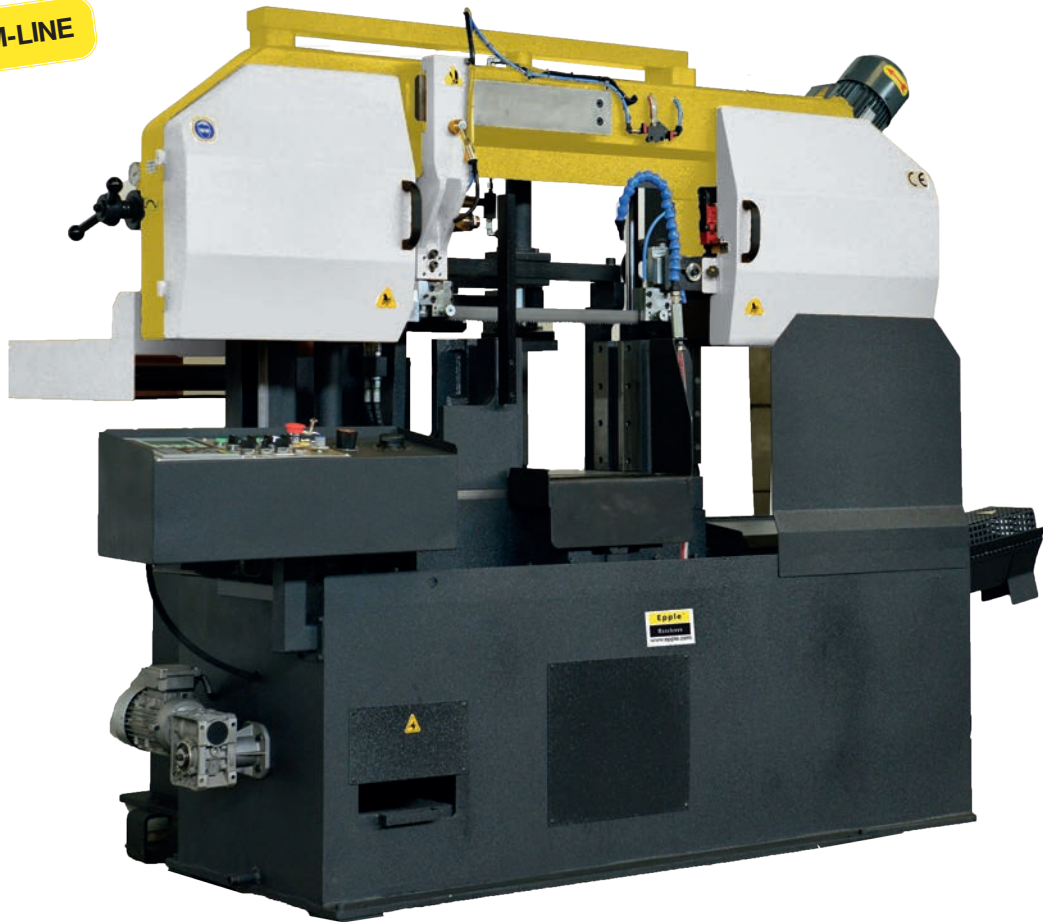

**Metal Band Saws**

### E-BSP 330 NC

- » band saw with servo drives
- » user-friendly on-screen PLC control
- » hydromechanical belt tensioning
- » chip brush
- » divided hydraulic vice
- » chip conveyor
- » servo driven feeds

### OPTIONAL ACCESSORIES

- » hydraulic blade tension
- » hexagon bundle vice
- » microspray coolant system
- » material roller conveyor
- » 4 kW motor
- » machine cladding

Description	E-BSP 330 NC
cutting capacity 0° circular	330 mm
cutting capacity 0° flat	360 x 330 mm
cutting capacity 0° rect.	330 mm
cutting speed	20 - 100 m/min stepless
saw blade length	4.380 x 34 x 1,1 mm
motor power	400 V / 50 Hz / 3 kW
dimensions (L x D x H)	2.100 x 2.300 x 1.560 mm
infeed height	850 mm
weight	2.120 kg
<b>E-BSP 330 NC</b>	
<b>EAN</b>	<b>4260364297348</b>
<b>Item No.</b>	<b>330 2330</b>

### STANDARD



# E-BSPC 330 NC

## METAL BAND SAW

**NEW**

**PREMIUM-LINE**



DRILLING

MILLING

TURNING

SAWING

GRINDING

BENDING

CUTTING / PRESSING

OTHER MACHINES

ACCESSORIES

### E-BSPC 330 NC

- » band saw with servo drives
- » user-friendly on-screen PLC control
- » hydromechanical belt tensioning
- » chip brush
- » divided hydraulic vice
- » chip conveyor
- » full machine cladding

### OPTIONAL ACCESSORIES

- » hydraulic blade tension
- » hexagon-bundle vice
- » microspray coolant system
- » material roller conveyor
- » 4 kW Motor

### STANDARD



Description	E-BSPC 330 NC
cutting capacity 0° circular	330 mm
cutting capacity 0° flat	360 x 330 mm
cutting capacity 0° rect.	330 mm
cutting speed	20 - 100 m/min stepless
saw blade length	4.380 x 34 x 1,1 mm
motor power	400 V / 50 Hz / 3,0 kW
dimensions (L x D x H)	2.625 x 1.900 x 1.900 mm
infeed height	850 mm
weight	2.150 kg
<b>E-BSPC 330 NC</b>	
<b>EAN</b>	<b>4260364297706</b>
<b>Item No.</b>	<b>330 2331</b>



# E-BS 350 V

## METAL BAND SAW

**NEW**

**PREMIUM-LINE**



STANDARD



Description	E-BS 350 V
cutting capacity 0°	circular 350 mm flat 400 x 350 mm rectangular 350 mm
mitre cut at 30°	circular 320 mm flat 400 x 350 mm rectangular 320 mm
mitre cut at 45°	circular 320 mm flat 290 x 300 mm rectangular 290 mm
mitre	up to 45°
cutting speed	20 - 100 m/min
saw band length	4.160 x 34 x 1,1 mm
motor power	400 V / 50 Hz / 2,2 kW
dimensions (L x D x H)	2.450 x 920 x 2.020 mm
inlet height	760 mm
weight	1.050 kg
<b>E-BS 350 V</b>	
<b>EAN</b>	<b>4260657652113</b>
<b>Item No.</b>	<b>330 0351</b>

### E-BS 350 V (SWIVELLING FULLY AUTOMATIC BANDSAW MACHINE)

- » fully automatic mitre band saw with an excellent price-performance ratio for sawing profiles and solid solid material in steel and other metals
- » length accuracy of +/- 0,3 mm
- » manually swivelling saw frame with hydraulic clamping for optimum mitre adjustment
- » mitre angle digitally readable on mobile control panel
- » hydraulic clamping of the horizontal vice
- » automatic saw frame lifting after end of cut
- » infinitely variable belt speed 20 - 100 m/min
- » belt guidance via carbide plates and rollers
- » chip brush driven via impeller

### OPTIONAL



You can find detailed accessories on page 289.

# E-BS 360 DGH ECO

## METAL BAND SAW

**PREMIUM-LINE**



### STANDARD

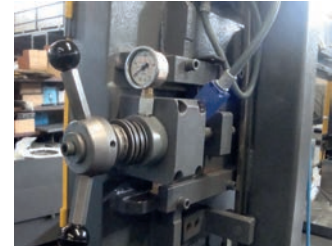

Description	E-BS 360 DGH ECO
cutting capacity 0°	circular 360 mm flat 510 x 360 mm rectangular 360 mm
mitre cut at +30° / -30°	circular 360 mm flat 510 x 360 mm rectangular 360 mm
mitre cut at +45° / -45°	circular 360 mm flat 390 x 360 mm rectangular 360 mm
mitre cut at +60°	circular 200 mm flat 200 x 360 mm rectangular 200 mm
mitre cut at -60°	circular 260 mm flat 260 x 360 mm rectangular 260 mm
mitre	up to ±60°
cutting speed	20 - 100 m/min
saw band length	4.800 x 34 x 1,1 mm
motor power	400 V / 50 Hz / 3 kW
dimensions (L x D x H)	2.800 x 1.210 x 1.870 mm
inlet height	860 mm
weight	1.450 kg
<b>EAN</b>	<b>4260364296068</b>
<b>Item No.</b>	<b>330 2361</b>

### E-BS 360 DGH ECO (WITH CLAMPING SPRINGS FOR SAW BLADES)

- » semi-automatic double miter band saw in excellent price-performance ratio for sawing profiles and solid material in steel and other metals
- » robustly constructed monoblock saw frame
- » manual swiveling saw frame with hydraulic clamping to the optimum swivel adjustment
- » mitre angle can be read digitally on mobile control panel
- » hydraulic clamping of the horizontal clamping block
- » automatic sawmill lifting after cutting
- » infinitely adjustable belt speed 20 - 100 m/min
- » hydraulic mechanical tensioning
- » tape guide on hard metal plates and rolls
- » thermal overload protection and undervoltage release
- » automatic shutdown after cutting
- » automatic belt breakage protection
- » chip brush driven by impeller

### OPTIONAL



You can find detailed accessories on page 289.

DRILLING

MILLING

TURNING

SAWING

GRINDING

BENDING

CUTTING / PRESSING

OTHER MACHINES

ACCESSORIES



# E-BS 360 DGH / E-BS 440 DGH

## METAL BAND SAWS

**PREMIUM-LINE**

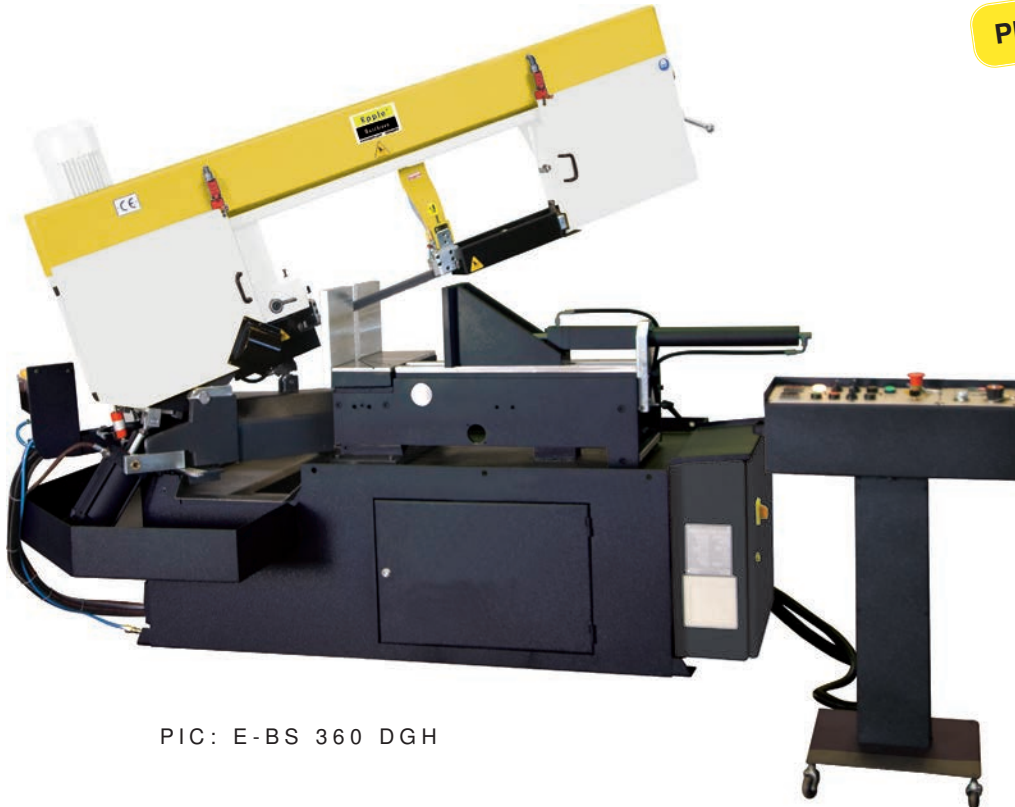

PIC: E-BS 360 DGH

**Metal Band Saws**

Description	E-BS 360 DGH	E-BS 440 DGH
cutting capacity 0°	circular 360 mm flat 610 x 360 mm rectangular 360 x 360 mm	circular 440 mm flat 610 x 440 mm rectangular 440 x 440 mm
mitre cut at +30° / -30°	circular 360 mm flat 610 x 360 mm rectangular 360 x 360 mm	circular 440 mm flat 500 x 440 mm rectangular 440 x 440 mm
mitre cut at +45° / -45°	circular 360 mm flat 490 x 360 mm rectangular 360 x 360 mm	circular 410 mm flat 410 x 440 mm rectangular 410 x 410 mm
mitre cut at +60° / -60°	circular 340 mm / 360 mm flat 300 x 360 mm / 360 x 360 mm rectangular 300 x 300 mm / 360 x 360 mm	circular 320 mm flat 440 x 250 mm / 285 x 440 mm rectangular 250 x 250 mm / 285 x 285 mm
mitre	from -60° up to +60°	from -60° up to +60°
cutting speed	20 - 100 m/min	20 - 100 m/min
saw band length	5.000 x 34 x 1,1 mm	5.200 x 34 x 1,1 mm
motor power	400 V / 50 Hz / 3 kW	400 V / 50 Hz / 3 kW
dimensions (L x D x H)	2.750 x 1.210 x 1.870 mm	2.900 x 1.210 x 1.870 mm
inlet height	860 mm	860 mm
weight	1.470 kg	1.570 kg
	<b>E-BS 360 DGH</b>	<b>E-BS 440 DGH</b>
<b>EAN</b>	<b>4260364290806</b>	<b>4260364290813</b>
<b>Item No.</b>	<b>330 2360</b>	<b>330 2440</b>

## E-BS 360 DGH / E-BS 440 DGH

- » semi-automatic machine
- » double mitre
- » inverter equipped: stepless driving speed adjustment 20 - 100 m/min
- » hydraulic vice
- » digital display for angle adjustment
- » hydraulic clamping of the saw arm, saw arm turning by hand
- » saw arm swivel +/-60°
- » stepless adjustable lowering speed of the saw arm by manometer to read the lowering speed
- » hydraulic balancing system to generate always the same sawing pressure and thereby reduce vibrations
- » slant toothed, conical heavy duty gearbox
- » hydraulic vice clamping across the entire clamping area
- » large cutting width of up to 610 mm
- » hydro mechanical strip tension readable on manometer

- » mobile control panel
- » high-quality hydraulic components
- » driven chip brush
- » stand and arm are heavy welded construction

### GENERAL INFORMATION

Our band saw machines with letter H (semi-automatic) in the type designation have the following working cycle:

After starting, the saw bow lowers to the lowest point, then switches off and the saw-bar moves up again.

For machines with hydraulic vice closes first the vice, then the upper one is cycle and then the vice opens again.

### STANDARD

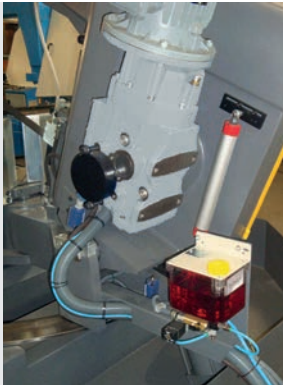
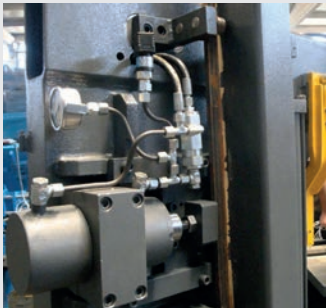
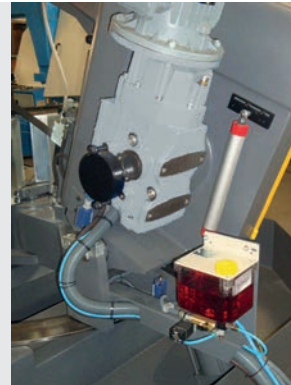
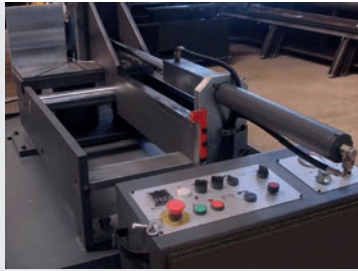
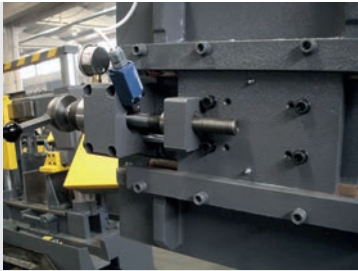

You can find detailed accessories on page 289.

### OPTIONAL



# E-BSP 360 GV / E-BSP 440 GV

## METAL BAND SAWS

**PREMIUM-LINE**

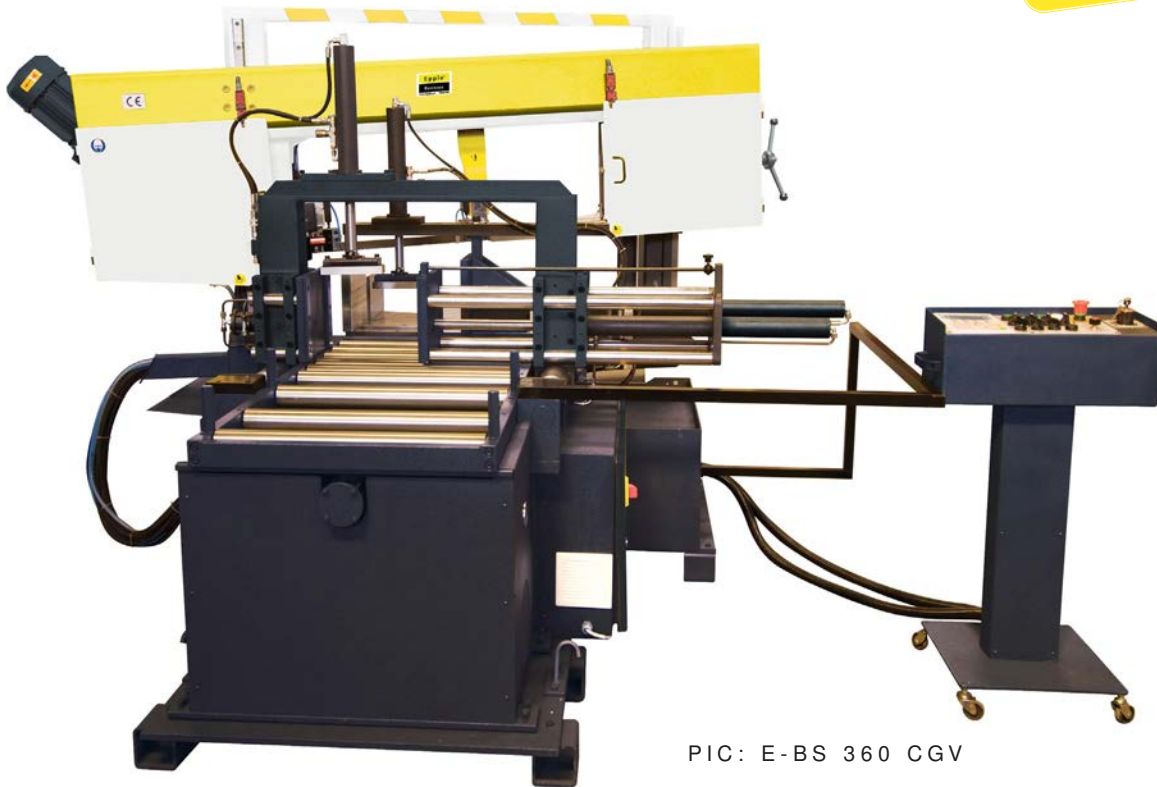

PIC: E-BS 360 CGV

**Metal Band Saws**

Description	E-BSP 360 GV	E-BSP 440 GV
cutting capacity 0°	circular 360 mm flat 610 x 360 mm rectangular 360 x 360 mm	circular 450 mm flat 610 x 425 mm rectangular 425 x 425 mm
cutting capacity +30°	circular 360 mm flat 590 x 360 mm rectangular 360 x 360 mm	circular 450 mm flat 560 x 425 mm rectangular 425 x 425 mm
cutting capacity +45°	circular 360 mm flat 450 x 360 mm rectangular 360 x 360 mm	circular 430 mm flat 430 x 425 mm rectangular 425 x 425 mm
cutting capacity +60°	circular 325 mm flat 280 x 360 mm rectangular 290 x 290 mm	circular 320 mm flat 260 x 425 mm rectangular 290 x 290 mm
mitre	from 0° up to +60°	from 0° up to +60°
cutting speed	20 - 100 m/min	20 - 100 m/min
saw band length	5.200 x 34 x 1,1 mm	5.400 x 41 x 1,3 mm
motor power	400 V / 50 Hz / 3 kW	400 V / 50 Hz / 4 kW
dimensions (L x D x H)	2.850 x 2.100 x 1.820 mm	2.850 x 2.100 x 1.950 mm
inlet height	705 mm	705 mm
weight	2.400 kg	2.480 kg
	<b>E-BSP 360 GV</b>	<b>E-BSP 440 GV</b>
<b>EAN</b>	<b>4260364290820</b>	<b>4260364290837</b>
<b>Item No.</b>	<b>330 3360</b>	<b>330 3440</b>



## E-BSP 360 GV / E-BSP 440 GV

- » fully automatic
- » Inverter Standard = stepless adjustable band speed 20 - 100 m/min
- » hydraulic vice
- » digital display for angle display
- » saw bow inclined by 3°
- » due to sensors automatic saw speed adjustment
- » hydr. clamping of the saw arm, rotation of the saw arm by hand up to 500 mm material feed at up to 12 times programmable gives a total of up to 6 m of material length
- » hydromechanical tape tension can be read off due to the manometer
- » hydraulic vice clamp over the entire clamping range
- » 10 cutting programs for length and number of pieces
- » heavy duty gearbox with helical gearing
- » large cutting width of up to 610 mm
- » mobile control panel
- » high-quality hydraulic components
- » powered chip brush
- » stand and arm are heavy welding construction
- » profile rail with linear technology for highly precise settings
- » double-sided feed clamping

**NEW**

PIC: NEW MODEL  
E-BSP 440 DG-NC  
AVAILABLE FROM  
SEPTEMBER 2020



## STANDARD

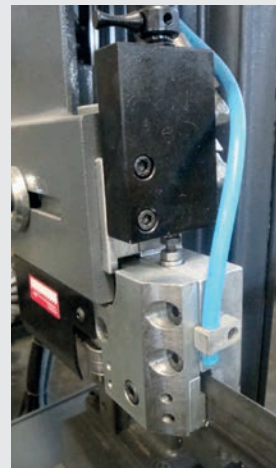
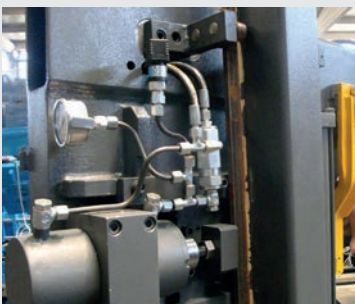
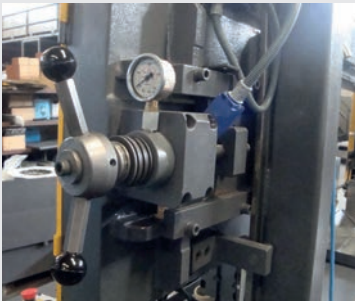

# E-BSP 360 DGH / E-BSP 440 DGH / E-BSP 440 DG-NC

## METAL BAND SAW

**PREMIUM-LINE**



PIC: E-BSP 360 DGH

You can find detailed accessories on page 289.

Description	E-BSP 360 DGH	E-BSP 440 DGH
cutting capacity 0°	circular 360 mm flat 640 x 360 mm rectangular 360 x 360 mm	circular 440 mm flat 640 x 440 mm rectangular 440 x 440 mm
mitre cut at +30° / -30°	circular 360 mm flat 510 x 360 mm rectangular 360 x 360 mm	circular 440 mm flat 510 x 440 mm rectangular 440 x 440 mm
mitre cut at +45° / -45°	circular 360 mm flat 390 x 360 mm rectangular 360 x 360 mm	circular 440 mm / 390 mm flat 400 x 440 mm / 390 x 440 mm rectangular 400 x 400 mm / 390 x 390 mm
mitre cut at +60°	circular 310 mm flat 250 x 360 mm rectangular 270 x 270 mm	circular 250 mm flat 250 x 440 mm rectangular 250 x 250 mm
mitre	from -30 up to +60°	from -30 up to +60°
cutting speed	20 - 100 m/min	20 - 100 m/min
saw band length	5.000 x 34 x 1,1 mm	5.200 x 41 x 1,3 mm
motor power	400 V / 50 Hz / 3 kW	400 V / 50 Hz / 4 kW
dimensions (L x D x H)	3.000 x 1.200 x 1.910 mm	3.100 x 1.200 x 1.910 mm
inlet height	800 mm	800 mm
weight	1.635 kg	1.780 kg
	<b>E-BSP 360 DGH</b>	<b>E-BSP 440 DGH</b>
<b>EAN</b>	4260364298277	4260364290844
<b>Item No.</b>	330 1361	330 4440



**E-BSP 360 DGH / E-BSP 440 DGH /  
E-BSP 440 DG-NC**

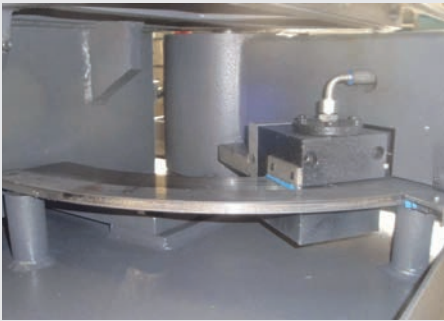
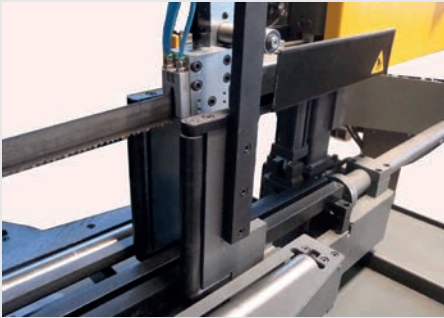

- » semi-automatic machine (E-BSP 360 and 440 DG)
- » full automatic machine (E-BSP 440 DG-NC)
- » double mitre
- » inverter equipped: stepless driving speed adjustment 20 - 100 m/min
- » hydraulic vice
- » digital display for angle display
- » hydraulic clamping of the saw arm,  
manual turning of the saw arm (E-BSP 360 and 440 DG),  
saw arm rotation automatic (E-BSP 440 DG-NC)
- » saw arm swivel +60° / -30°
- » saw band inclined by 3°
- » automatic saw speed adaption by sensors
- » synchronization of strip guide and vice, saw bow made of solid steel
- » slant toothed, conical heavy duty gearbox
- » hydraulic vice clamping across the entire clamping area
- » large width of cut up to 640 mm
- » hydro mechanical strip tension readable on manometer
- » mobile control panel
- » high-quality hydraulic components
- » driven chip brush
- » stand and arm are heavy welded construction
- » profile rail is adjusted by linear technique for highly precise movement

**OPTIONAL**

- » micro cooling system
- » hydraulic sheet tension

**STANDARD**

Description	E-BSP 440 DG-NC
cutting capacity 0°	circular 440 mm flat 640 x 440 mm rectangular 440 x 440 mm
mitre cut at +30° / -30°	circular 440 mm flat 510 x 440 mm rectangular 440 x 440 mm
mitre cut at +45° / -45°	circular 440 mm / 390 mm flat 400 x 440 mm / 390 x 440 mm rectangular 400 x 400 mm / 390 x 390 mm
mitre cut at +60°	circular 250 mm flat 250 x 440 mm rectangular 250 x 250 mm
mitre	von -30 bis +60°
cutting speed	20 - 100 m/min
saw band length	5.200 x 41 x 1,3 mm
motor power	400 V / 50 Hz / 4 kW
dimensions (L x D x H)	3.100 x 1.200 x 1.910 mm
inlet height	800 mm
weight	1.780 kg
	<b>E-BSP 440 DG-NC</b>
<b>EAN</b>	<b>4260657651796</b>
<b>Item No.</b>	<b>330 4441</b>

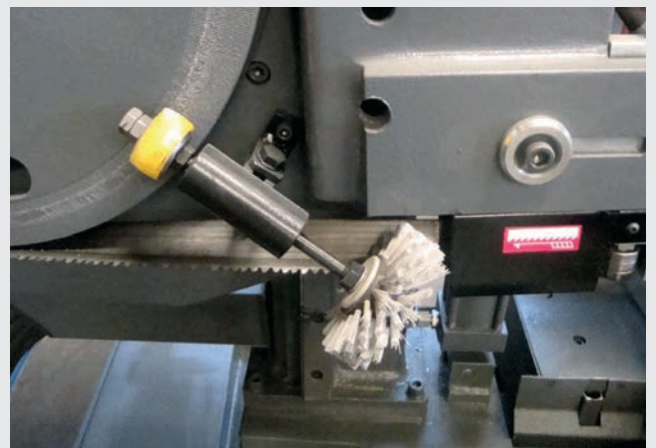
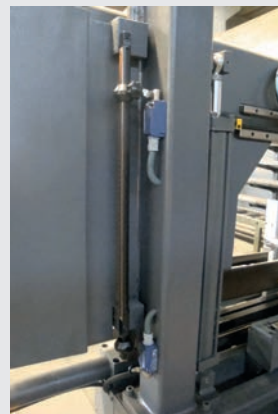

# E-BS 440 V / E-BSP 460 V

## METAL BAND SAWS

PREMIUM-LINE

NEW

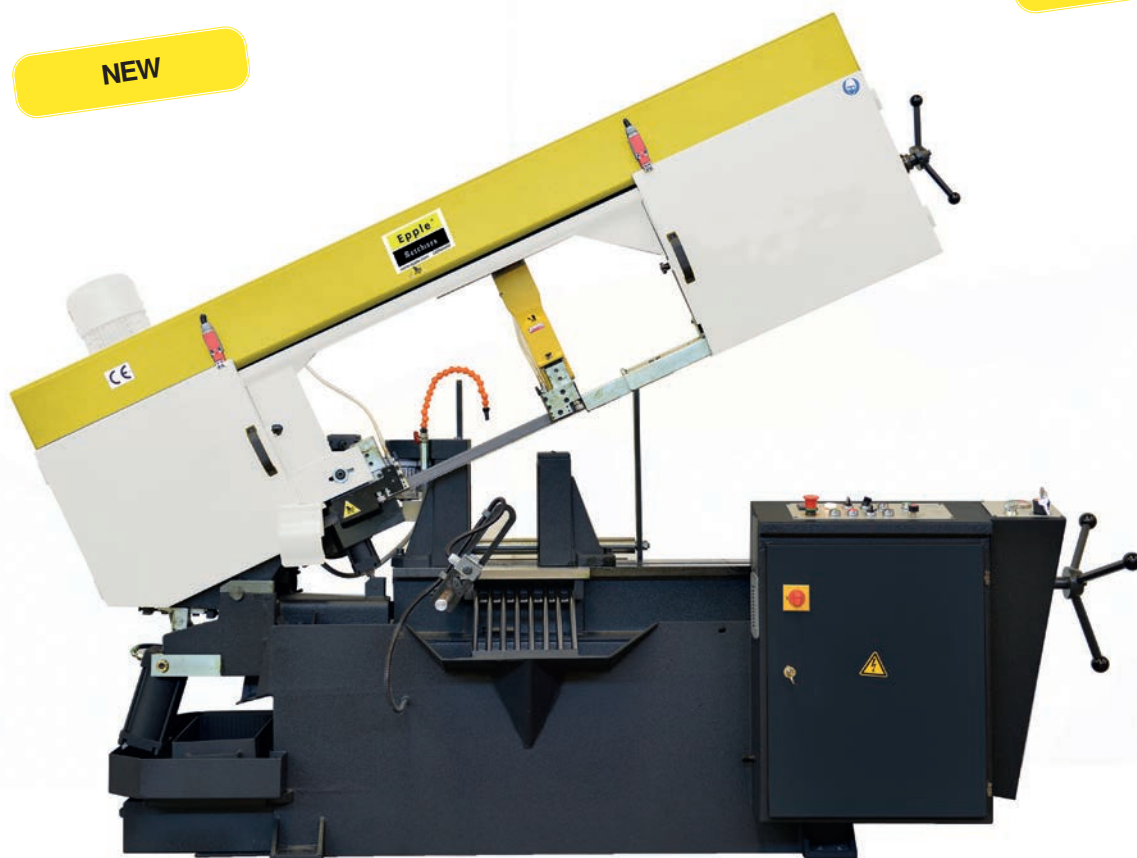

PIC: E-BS 460 V

Metal Band Saws

Description	E-BS 440 V	E-BS 460 V
cutting capacity circular	440 mm	460 mm
cutting capacity flat	580 x 440 mm	470 x 460 mm
cutting capacity rectangular	440 mm	460 mm
motor power main driver	3 kW	4 kW
power of the hydraulic pump	0,55 kW	0,55 kW
motor power of the coolant pump	0,12 kW	0,12 kW
band speed, stepless	20 - 100 m/min	20 - 100 m/min
saw band dimensions	5.200 x 34 x 1,1 mm	5.200 x 41 x 1,3 mm
height of the working surface	735 mm	590 mm
length	2.630 mm	3.100 mm
depth	1.110 mm	1.000 mm
height	1.710 mm	1.800 mm
weight	1.140 kg	1.655 kg
	<b>E-BS 440 V</b>	<b>E-BS 460 V</b>
<b>EAN</b>	<b>4260364296082</b>	<b>4260364296082</b>
<b>Item No.</b>	<b>330 2441</b>	<b>330 2441</b>

You can find detailed accessories on page 289.

**E-BS 440 V / E-BSP 460 V**

- » fully automatic band saw for sawing thick-walled solid material, pipes and other profiles
- » roller feed of the material the front "tensioning rollers" are driven by a worm gear by means of an electric motor
- » the feed length of the material is preselected manually via an adjustable microswitch
- » the number of pieces to be cut is "controlled" by a piece counter
- » torsion-free welded construction with stable saw frame made of high-quality cast iron, made from one piece, guarantees smooth running, high cutting performance and long service life of the saw bands
- » infinitely variable belt speed
- » hydraulic mechanical tensioning
- » tape guide on hard metal plates and rolls
- » thermal overload protection and undervoltage release
- » automatic shutdown after cutting
- » infinitely variable overpressure control via hydraulic cylinder
- » automatic belt breakage protection

**STANDARD**



**OPTIONAL**

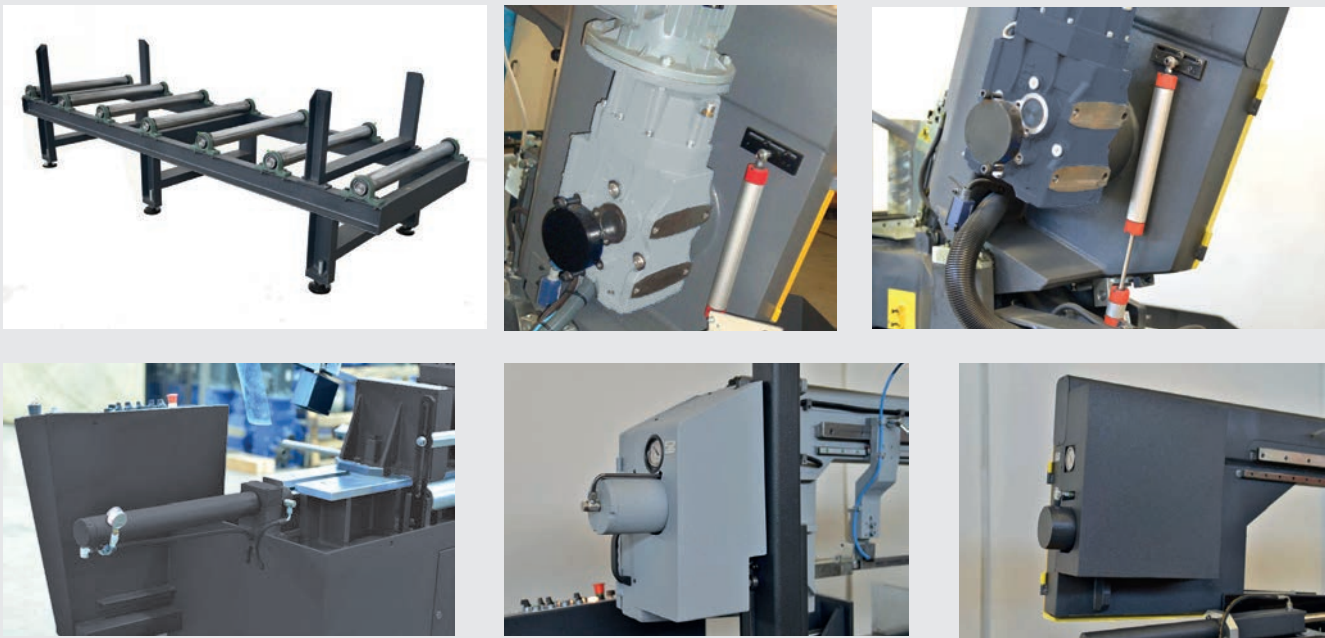

DRILLING

MILLING

TURNING

SAWING

GRINDING

BENDING

CUTTING / PRESSING

OTHER MACHINES

ACCESSORIES



**PREMIUM-LINE**

# E-BSP 540 GH

## METAL BAND SAW

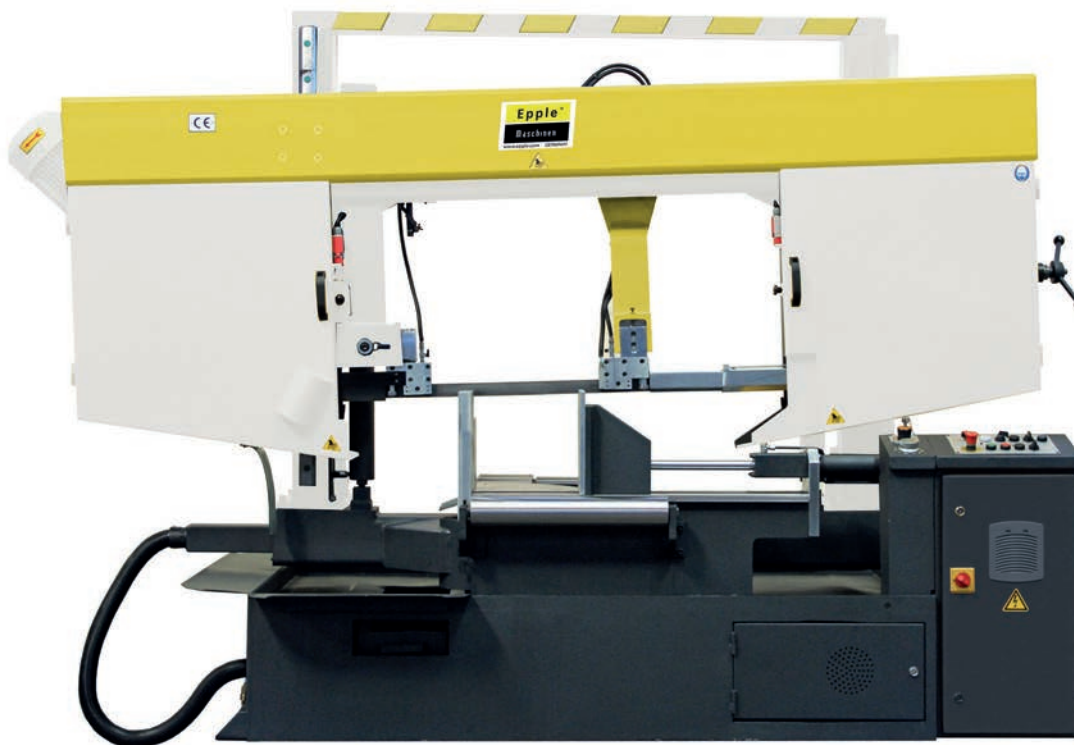

You can find detailed accessories on page 289.

**Metal Band Saw**

Description	E-BSP 540 GH
cutting capacity 0°	circular 540 mm flat 750 x 540 mm rectangular 540 mm
mitre cut at +30°	circular 540 mm flat 600 x 540 mm rectangular 540 mm
mitre cut at +45°	circular 510 mm flat 450 x 540 mm rectangular 450 mm
mitre cut at +45°	circular 270 mm flat 250 x 540 mm rectangular 250 mm
mitre	up to +60°
cutting speed	20 - 100 m/min
saw band length	6.000 x 41 x 1,3 mm
motor power	400 V / 50 Hz / 4 kW
dimensions (L x D x H)	3.000 x 1.300 x 2.150 mm
inlet height	695 mm
weight	2.445 kg
	<b>E-BSP 540 GH</b>
<b>EAN</b>	<b>4260364290851</b>
<b>Item No.</b>	<b>330 1540</b>

## E-BSP 540 GH

- » semi-automatic machine
- » mitre
- » inverter standard = stepless speed adjustment 20 - 100 m/min
- » hydraulic vice
- » digital display for angular display
- » hydraulic clamping of the saw arm, saw arm turning by hand
- » saw band inclined by 3°
- » automatic saw speed adaption via sensors
- » synchronisation of belt guide and vice
- » saw bow made of solid steel
- » diagonal teethed and tapered heavy duty gear
- » hydraulic vice clamping over the entire clamping range
- » large cutting width up to 750 mm
- » hydromechanic tape tension readable via manometer
- » mobile control panel
- » high quality hydraulic components
- » driven chip brush
- » fundament and arm are massive welded constructions
- » vertical movement with high-precision linear guides

### STANDARD

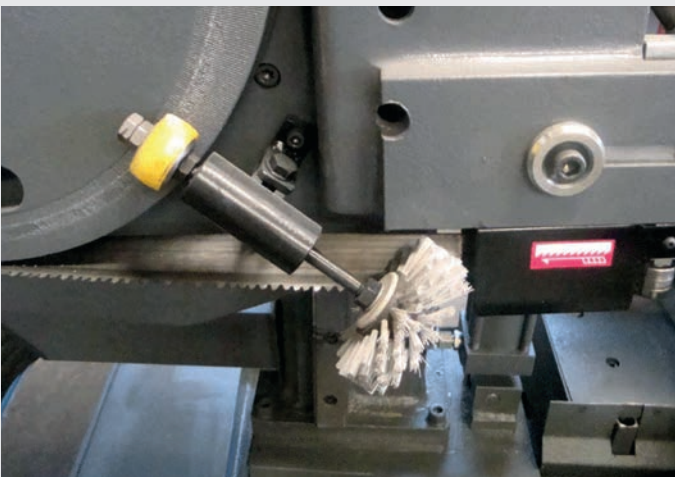
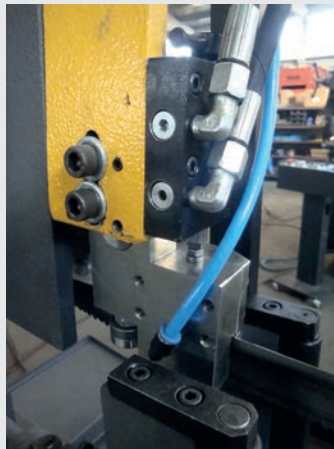

### OPTIONAL



micro cooling system

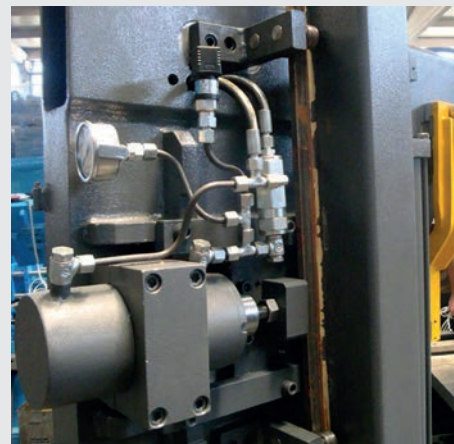

hydraulic blade tensioning



# E-BSP 560 DGH

## METAL BAND SAW

**PREMIUM-LINE**

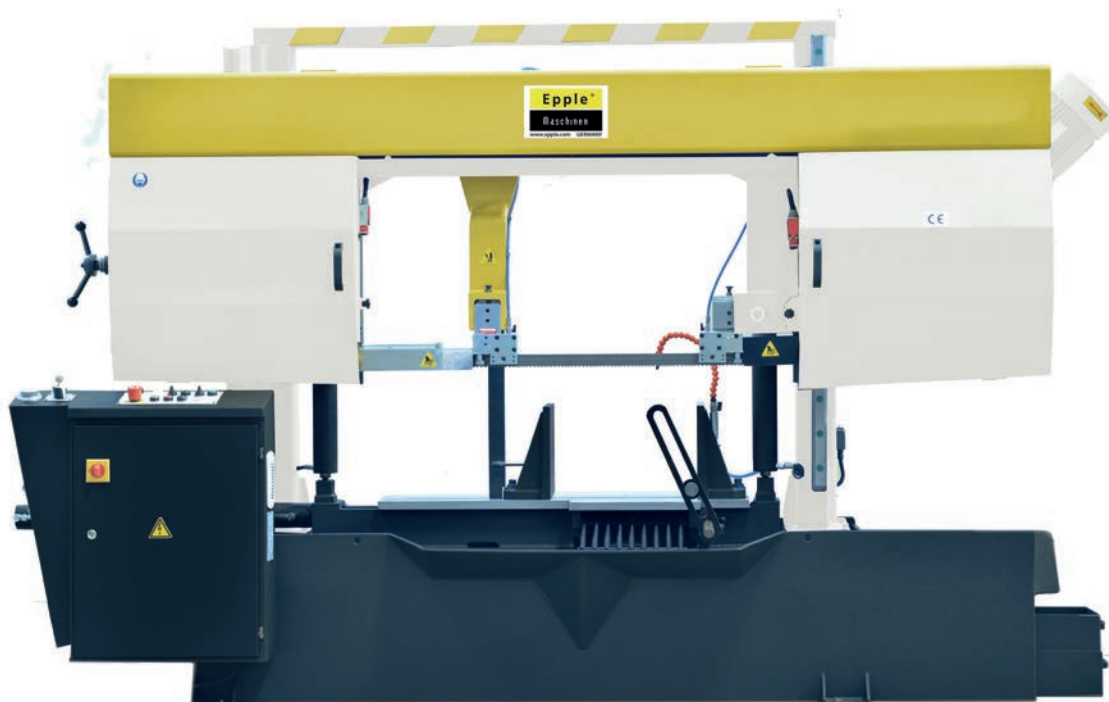

**Metal Band Saw**

Description	E-BSP 560 DGH
cutting capacity 0°	circular 560 mm flat 820 x 540 mm rectangular 540 mm
mitre cut at -30°	circular 500 mm flat 705 x 540 mm rectangular 540 mm
mitre cut at -45°	circular 550 mm flat 550 x 540 mm rectangular 540 mm
mitre cut at +60°	circular 360 mm flat 360 x 540 mm rectangular 360 mm
mitre cut at +30°	circular 560 mm flat 705 x 540 mm rectangular 540 mm
mitre cut at +45°	circular 550 mm flat 550 x 540 mm rectangular 540 mm
mitre	+60° up to -45°
cutting speed	20 - 100 m/min
saw band length	6.800 x 41 x 1,3 mm
motor power	400 V / 50 Hz / 4 kW
dimensions (L x D x H)	3.800 x 1.750 x 2.350 mm
inlet height	880 mm
weight	3.200 kg
	<b>E-BSP 560 DGH</b>
<b>EAN</b>	<b>4260364294361</b>
<b>Item No.</b>	<b>330 1560</b>

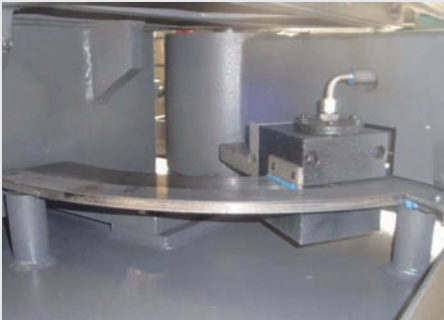
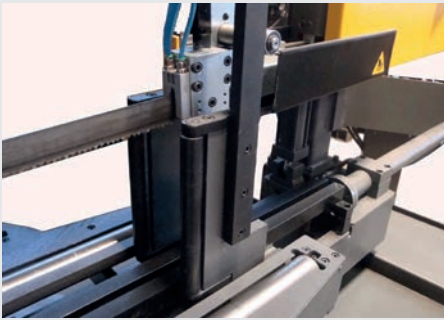

### E-BSP 560 DGH

- » semi-automatic machine
- » mitre
- » inverter standard = stepless speed adjustment 20 - 100 m/min
- » hydraulic vice
- » digital display for angular display
- » hydraulic clamping of the saw arm, saw arm turning by hand
- » saw band inclined by 3°
- » automatic saw speed adaption via sensors
- » synchronisation of belt guide and vice
- » saw bow made of solid steel
- » diagonal teathed and tapered heavy duty gear
- » hydraulic vice clamping over the entire clamping range
- » hydromechanic tape tension readable via manometer
- » mobile control panel
- » high quality hydraulic components
- » driven chip brush
- » fundament and arm are massive welded constructions
- » vertical movement with high-precision linear guides

### OPTIONAL

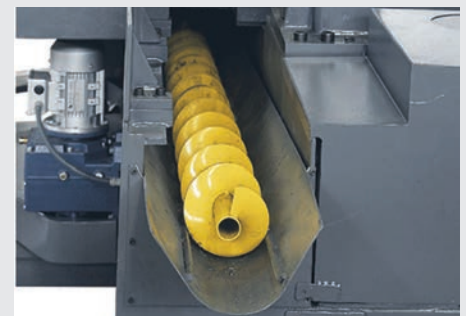

You can find detailed accessories on page 289.

# E-BSP 570 CNC

## METAL BAND SAW

**PREMIUM-LINE**



**Metal Band Saw**

Description	E-BSP 570 CNC
cutting capacity	circular 570 mm flat 600 x 570 mm rectangular 570 mm
hydraulic pump	2,2 kW
hydraulic pump motor	0,2 kW
chip conveyor	0,37 kW
servomotor power supply	2 kW
feed per stroke	700 mm
cutting speed	20 - 100 m/min
saw blade length	7.400 x 54 x 1,6 mm
motor power	400 V / 50 Hz / 7,5 kW
dimensions (L x D x H)	3.500 x 2.000 x 2.700 mm
inlet height	805 mm
weight	5.900 kg
	<b>E-BSP 570 CNC</b>
<b>EAN</b>	<b>4260364297355</b>
<b>Item No.</b>	<b>330 2570</b>



## E-BSP 570 CNC

The E-BSP 570 CNC is designed to maximize the cutting performance of heavy metals, profiles and tubes in high volume production.

The machine's automatic cutting pressure control extends the life of the saw blade by up to 50%.

The fully automatic control of the material as well as the saw feed is driven by servo motors.

- » intelligent cutting and user-friendly touch screen with Omron CNC cutting program
- » ability to store up to 50 different cutting lengths in 100 different programs
- » cutting-parameter are CNC-controlled for optimal processing of the workpiece
- » manual input of cutting parameters
- » servo feeding with 700 mm stroke
- » the guide arm moves on a linear guideway and moves in coordination with the movable vice jaw
- » hydraulically operated carbide blade guides
- » motion detector and automatic deflection sensor
- » vibration-free cutting with 3 linear paths
- » motorized chip brush
- » planetary gear

## OPTIONAL

- » Hydraulic Top-Clamping
- » 15 kW Motor



Hexagonal vice for bundling pipes



Microspray-coolant system

You can find detailed accessories on page 289.



# E-BSP 650 DGH NC / E-BSP 750 DGH-NC

## METAL BAND SAW

**PREMIUM-LINE**

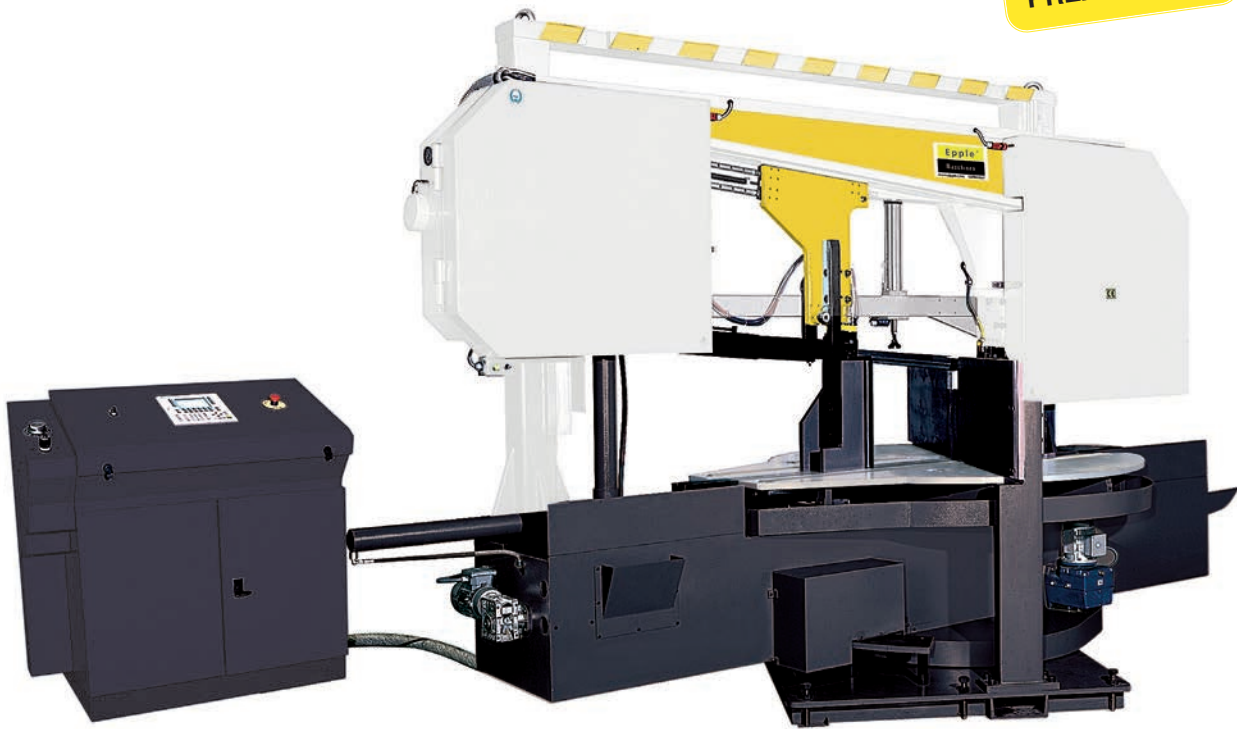

**Metal Band Saws**

Description	E-BSP 650 DGH NC	E-BSP 750 DGH-NC
cutting capacity 0°	circular 650 mm flat 1.000 x 600 mm rectangular 600 x 600 mm	circular 440 mm flat 640 x 440 mm rectangular 440 x 440 mm
mitre cut at +30° / -30°	circular 650 mm flat 840 x 600 mm rectangular 600 x 600 mm	circular 440 mm flat 510 x 440 mm rectangular 440 x 440 mm
mitre cut at +45° / -45°	circular 650 mm flat 660 x 600 mm rectangular 600 x 600 mm	circular 440 mm / 390mm flat 400 x 440 mm / 390 x 440 mm rectangular 400 x 400 mm / 390 x 390 mm
mitre cut at 60°	circular 440 mm flat 440 x 600 mm rectangular 440 x 440 mm	circular 250 mm flat 250 x 440 mm rectangular 250 x 250 mm
mitre	from -45° up to +60°	from -45° up to +60°
cutting speed	20 - 100 m/min	20 - 100 m/min
saw band length	8.400 x 54 x 1,6 mm	9.600 x 54 x 1,6 mm
motor power	400 V / 50 Hz / 7,5 kW	400 V / 50 Hz / 7,5 kW
dimensions (L x D x H)	4.750 x 1.970 x 2.630 mm	5.050 x 2.200 x 2.900 mm
inlet height	880 mm	880 mm
weight	6.520 kg	6.700 kg
	<b>E-BSP 650 DGH-NC</b>	<b>E-BSP 750 DGH-NC</b>
<b>EAN</b>	<b>4260364290868</b>	<b>4260364299694</b>
<b>Item No.</b>	<b>330 5650</b>	<b>330 5750</b>

## E-BSP 650 DGH NC / E-BSP 750 DGH-NC

- » semi-automatic machine
- » double mitre
- » inverter equipped: stepless speed adjustment 20 - 100 m/min
- » hydraulic vice
- » hydraulic strip clamping
- » arm swivel NC-controlled from -45° to +60°
- » saw band inclined by 5°
- » stepless adjustable lowering speed
- » motor driven chip conveyor
- » motor driven chip brush
- » rapid sensor controlled positioning of the saw bow to the material
- » synchronization of the band guide and the vice
- » slant toothed, conical heavy duty gearbox
- » large cutting width up to 1.000 mm
- » saw bow made of solid steel
- » high-quality hydraulic components
- » profile rail in linear technique for precise adjustments

### STANDARD

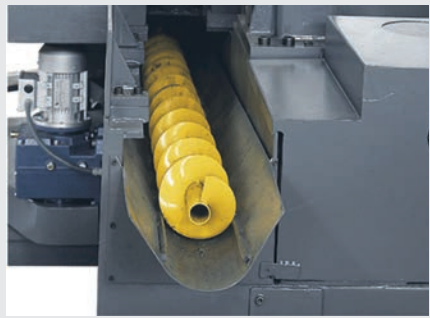
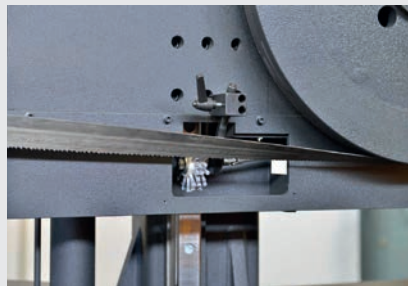
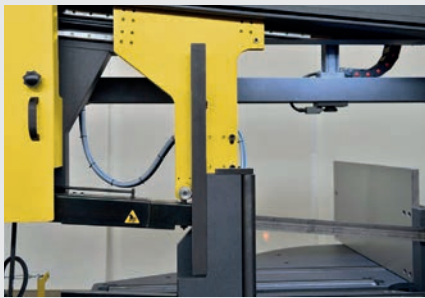

### OPTIONAL



You can find detailed accessories on page 289.

# E-BSP 810 GH

## METAL BAND SAW

**PREMIUM-LINE**

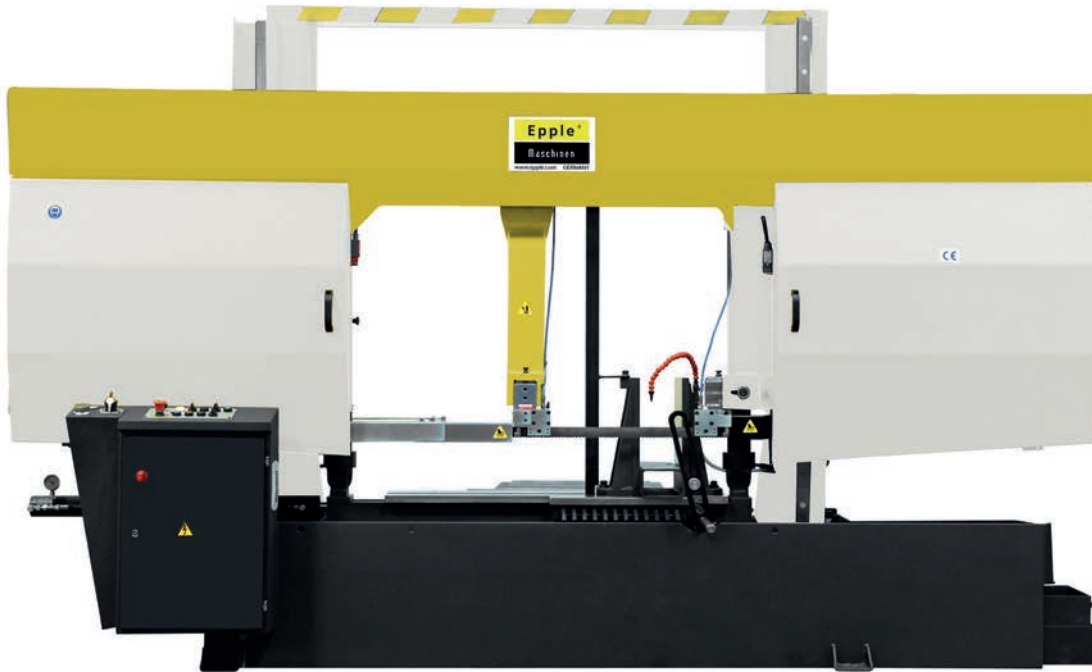

**Metal Band Saws**

### E-BSP 810 GH

- » semi-automatic machine
- » mitre
- » inverter equipped: stepless driving speed adjustment 20 - 100 m/min
- » hydraulic vice
- » digital readout for angle display
- » hydraulic clamping of the saw arm, manual turning of saw arm
- » saw blade inclined by 2° in cutting direction
- » automatic saw speed adaption by sensors
- » synchronization of strip guide and vice, saw bow made of solid steel
- » slant toothed, conical heavy duty gearbox
- » hydraulic strip clamping
- » large cutting width up to 810 mm
- » hydromechanical tape tension readable via manometer
- » high-quality hydraulic components
- » powered chip brush
- » stand and arm made of heavy welded construction
- » vertical movement with high-precision linear guides

Description	E-BSP 810 GH
cutting capacity 0°	circular 810 mm flat 750 x 910 mm rectangular 750 mm
mitre cut at +30°	circular 760 mm flat 740 x 750 mm rectangular 740 mm
mitre cut at +45°	circular 600 mm flat 750 x 600 mm rectangular 600 mm
mitre cut at +60°	circular 360 mm flat 750 x 360 mm rectangular 360 mm
mitre	up to +60°
cutting speed	20 - 100 m/min
saw band length	8.200 x 41 x 1,3 mm
motor power	400 V / 50 Hz / 4 kW
dimensions (L x D x H)	4.020 x 1.600 x 2.450 mm
inlet height	725 mm
weight	3.970 kg
	<b>E-BSP 810 GH</b>
<b>EAN</b>	<b>4260364290875</b>
<b>Item No.</b>	<b>330 1810</b>

# E-BSP 820 H / E-BSP 820 V

## METAL BAND SAW

NEW

PREMIUM-LINE

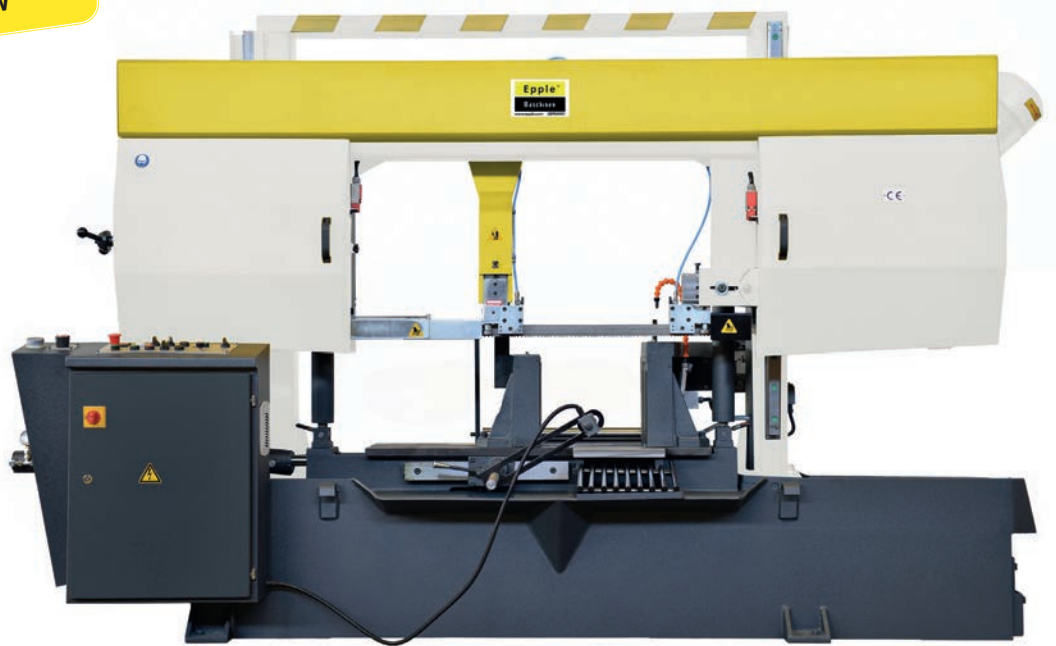

The **E-BSP 820 H** is a semi-automatic machine in two-column design. With its medium cutting range (round up to 820 mm, flat 820 x 800 mm) it is ideally suited for cutting solid material as well as tubes, profiles and beams in steel cutting. Only 90° cuts are possible with this machine. Precision hard metal saw blade guides as well as a sturdy, rigid construction of the machine ensure a precise cut. The basic equipment of this machine includes a full stroke lifting cylinder, a continuously adjustable belt speed. The saw blade runs over a large drive and deflection wheel which ensures a longest possible service life. **Also available as fully automatic machine (E-BSP 820 V).**

Saw blades see page 124 - 127, coolant emulsion see on page 312.

Description	E-BSP 820 H	E-BSP 820 V
cutting capacity circular	820 mm	820 mm
cutting capacity flat	850 x 820 mm	850 x 820 mm
cutting capacity rectangular	820 x 820 mm	820 x 820 mm
motor power main driver	7,5 kW	7,5 kW
power of the hydraulic pump	1,5 kW	1,5 kW
motor power of the coolant pump	0,12 kW	0,12 kW
band speed, stepless	20 - 100 m/min	20 - 100 m/min
saw band dimensions	8.200 x 54 x 1,6 mm	8.200 x 54 x 1,6 mm
height of the working surface	585 mm	585 mm
weight	3.424 kg	3.250 kg
length	3.900 mm	3.900 mm
depth	1.200 mm	1.200 mm
height	2.350 mm	2.350 mm
	<b>E-BSP 820 H</b>	<b>E-BSP 820 V</b>
<b>EAN</b>	<b>4260364290905</b>	<b>4260364296099</b>
<b>Item No.</b>	<b>330 1820</b>	<b>330 2820</b>

DRILLING

MILLING

TURNING

SAWING

GRINDING

BENDING

CUTTING / PRESSING

OTHER MACHINES

ACCESSORIES



# E-BSP 1.020 H

## METAL BAND SAW

NEW

PREMIUM-LINE



Metal Band Saw

Description	E-BSP 1.020 H
cutting capacity 0°	circular 1.020 mm flat 1.020 x 1.020 mm rectangular 1.020 mm
mitre cut at +45°	circular 675 mm flat 675 x 1.020 mm rectangular 675 mm
mitre	up to +45°
cutting speed	20 - 100 m/min
saw band length	9.500 x 54 x 1,6 mm
motor power	400 V / 50 Hz / 7,5 kW
dimensions (L x D x H)	4.500 x 1.700 x 2.750 mm
inlet height	535 mm
weight	5.860 kg
	<b>E-BSP 1.020 H</b>
<b>EAN</b>	<b>4260364294378</b>
<b>Item No.</b>	<b>330 1020</b>

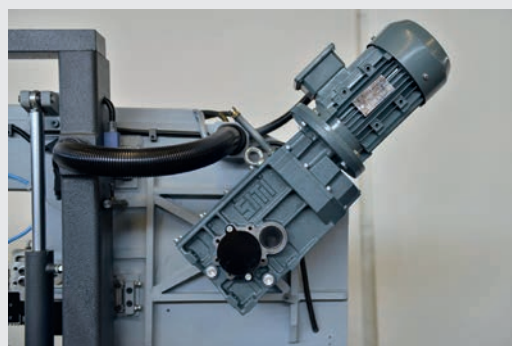

PIC: BEVEL-GEAR

## E-BSP 1.020 H

- » hydraulic vice
- » digital display for angle display
- » substructure and arm heavy welding construction
- » synchronization of tape guide and vice
- » sawframe made of solid steel
- » mobile control panel
- » high-quality hydraulic components
- » mitre settings via the vice jaws

### STANDARD

- » inverter
- » hydraulic saw band tension
- » pressure adjustable
- » optical height adjustment
- » material transport rollers front/rear



PIC: CONTROL PANEL

### OPTIONAL ACCESSORIES

- » chip conveyer
- » micro lubrication system
- » 3 m Material roll table
- » 3 m motorized roller table

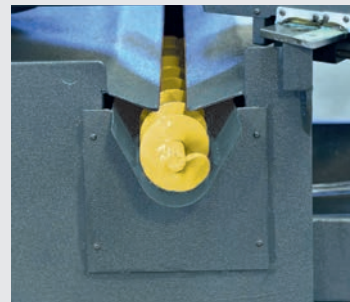

PIC: OPTIONAL:  
CHIP CONVEYOR

PIC: BACKSIDE OF E-BSP 1.020 H

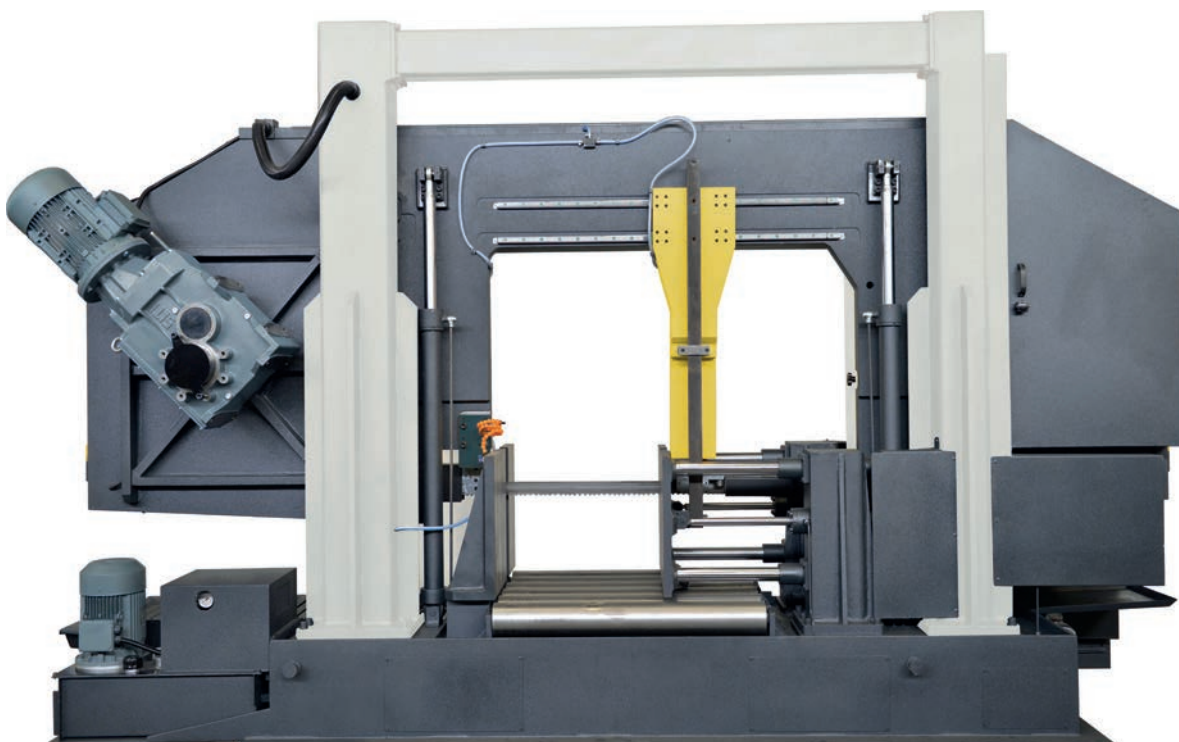

# E-BSP 1.110 H / E-BSP 1.110 HL

## METAL BAND SAWS

NEW

PREMIUM-LINE



PIC: E-BSP 1.110 H

Description	E-BSP 1.110 H	E-BSP 1.110 HL
cutting capacity circular	1.110 mm	1.110 mm
cutting capacity flat	1.110 x 1.110 mm	1.110 x 1.300 mm
cutting capacity rectangular	1.110 mm	1.110 mm
motor power main driver	11 kW	11 kW
power of the hydraulic pump	4 kW	7,5 kW
motor power of the coolant pump	0,2 kW	0,2 kW
band speed, stepless	20 - 100 m/min	20 - 100 m/min
saw band dimensions	10.500 x 67 x 1,6 mm	10.900 x 67 x 1,6 mm
height of the working surface	545 mm	545 mm
height	2.975 mm	2.975 mm
length	4.800 mm	5.300 mm
width	1.500 mm	1.500 mm
weight	10.440 kg	11.390 kg
	<b>E-BSP 1.110 H</b>	<b>E-BSP 1.110 HL</b>
<b>EAN</b>	<b>4260364296105</b>	<b>4260364296112</b>
<b>Item No.</b>	<b>330 1110</b>	<b>330 1113</b>

The **E-BSP 1.110 H** and **E-BSP 1.110 HL** are semi-automatic machines in two-column construction, which are ideal for cutting solid material as well as pipes, profiles and beams in the middle section (up to 1.110 mm, flat 1.110 x 1.110 mm or 1.300 x 1.110 mm) steel cutting is suitable. With this machine are only 90° cuts possible. Precision hard metal saw blade guides as well as a sturdy, rigid construction of the machine ensure a precise cut. The basic equipment of this machine includes a full stroke lifting cylinder, a continuously adjustable belt speed. The saw blade runs over a large drive and deflection wheel which ensures a longest possible service life.

### STANDARD

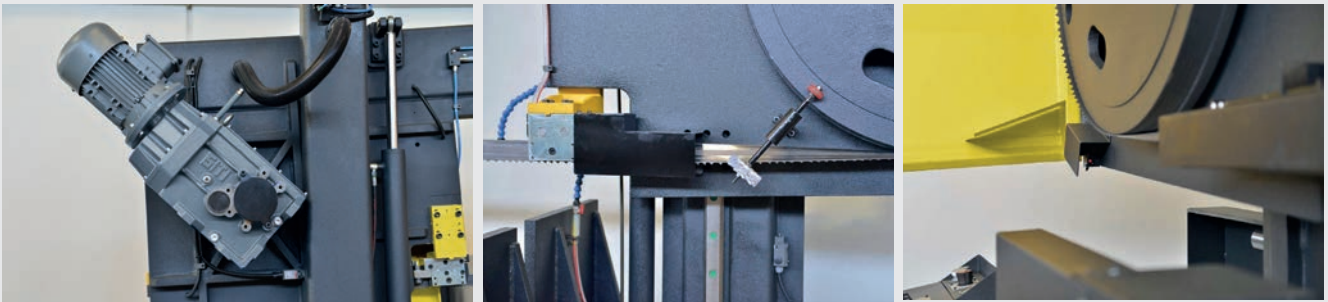

### OPTIONAL





# E-BSP 1.313 H / E-BSP 1.515 H / E-BSP 2.020 H

## METAL BAND SAWS

**PREMIUM-LINE**

**NEW**



**Metal Band Saws**

Description	E-BSP 1.313 H	E-BSP 1.515 H	E-BSP 2.020 H
cutting capacity circular	1.300 mm	1.500 mm	2.000 mm
cutting capacity flat	1.300 x 1.300 mm	1.510 x 1.500 mm	2.000 x 2.000 mm
cutting capacity rectangular	1.300 mm	1.500 mm	2.000 mm
motor power main driver	11 kW	15 kW	18,5 kW
power of the hydraulic pump	7,5 kW	7,5 kW	7,5 kW
motor power of the coolant pump	0,2 kW	2 x 0,2 kW	2 x 2,2 kW
band speed, stepless	20 - 100 m/min	10 - 70 m/min	20 - 100 m/min
saw band dimensions	12.100 x 67 x 1,6 mm	13.300 x 80 x 1,6 mm	on request
height of the working surface	545 mm	545 mm	545 mm
height	3.175 mm	4.055 mm	on request
length	5.300 mm	6.400 mm	on request
depth	1.500 mm	2.250 mm	on request
weight	11.500 kg	25.320 kg	on request
	<b>E-BSP 1.313 H</b>	<b>E-BSP 1.515 H</b>	<b>E-BSP 2.020 H</b>
<b>EAN</b>	<b>4260364296129</b>	<b>4260364296136</b>	<b>4260657651901</b>
<b>Item No.</b>	<b>330 1300</b>	<b>330 1515</b>	<b>330 2020</b>

**E-BSP 1.313 H, E-BSP 1.515 H and E-BSP 2.020 H** are semi-automatic machines in torsion-resistant steel construction with two-column guidance of the saw bow with large dimensioned linear and flat guides. The saw bow is a monoframe construction. Hydraulic saw bow feed with pressure control system for optimum adaptation to the sawing task. Through infinitely variable feed speed 20-100 m/min and cutting force control, saw bands can be used more universally and cost-savingsly. The machines have powerful, low-maintenance motors for reliable operation.

STANDARD

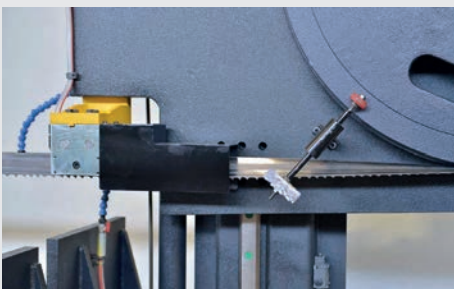

OPTIONAL



# ASSISTANCE FOR THE CORRECT SELECTION AND HANDLING OF SAW BANDS

## ESPECIALLY ADAPTED TO OUR METAL BAND SAWS

### TOOTH PITCH

variable tooth division	engagement length (mm)	
	up	to
10-14		30
8-12	20	50
6-10	25	60
5-8	35	80
4-6	50	100
4-5	70	120
3-4	80	150
2-3	120	350
1,4-2	250	600
1,0-1,4	400	1000
0,75-1,25	700	1400
0,7-1,0	900	3000

You may choose between constant and variable tooth pitch. Here the contact length of the blade in the work piece is decisive. Both tables left handed show the limit values.

Low-vibration and low noise sawing due to variable tooththing. Because of variable tooththing, larger material cross section are optimal covered.

constant tooth division	engagement length (mm)	
	up	to
14		15
10	15	30
8	30	50
6	50	80
4	80	120
3	120	200



### SAWING TUBES AND PROILES

S mm	external pipe diameter (mm) / tooth division Tz in ZpZ								
	20	40	60	80	100	120	150	200	300
2	14	14	14	14	14	14	10-14	10-14	8-12
3	14	14	10-14	10-14	10-14	10-14	8-12	8-12	6-10
4	14	14	10-14	10-14	8-12	8-12	8-12	8-12	5-8
5	14	10-14	10-14	10-14	8-12	8-12	8-12	6-10	5-8
6	14	10-14	10-14	8-12	8-12	8-12	8-12	5-8	5-8
8	14	10-14	8-12	8-12	8-12	6-10	6-10	5-8	4-6
10		8-12	6-10	6-10	6-10	5-8	5-8	4-6	4-6
12		8-12	6-10	6-10	5-8	5-8	4-6	4-6	4-6
15		8-12	6-10	5-8	5-8	4-6	4-6	4-6	3-4
20				5-8	4-6	4-6	4-6	3-4	3-4
30				4-6	4-6	4-6	3-4	3-4	3-4
50						3-4	3-4	3-4	2-3
75								2-3	2-3
100									2-3

# RUNNING - IN SAW BANDS

THE CORRECT RUNNING-IN GUARANTEES A LONG SERVICE LIFE

1. Sharp cutting edges with extremely small edge
2. Correct running-in the saw blade guarantees an ideal rounding cutting edge
3. Wrong running-in the saw blade damages micro splitters



## BI - METAL SAW BANDS

Sharp cutting edges with extremely small edge radiuses are the condition for high cutting capacities of the saw bands. In order to achieve an ideal service life, we recommend you to use the saw bands accordingly. Determine the correct cutting speed and the feed depending on the material and the dimension of your cutting material. It is important that the saw blade is used at approximately 50% of the determined feed. So it will be avoided that damages occur due to extremely sharp tooth cutting edges at too large chip thickness caused by micro splitters.

## BANDWIDTH

With horizontal machines the band width is specified by the manufacturer. Vertical blade saw machines allow higher variations of the blade width. However, the general rule is the wider the band saw blade, the higher its stability. In case of contour cuts the smallest radius to be cut is the limiting factor for the blade width. Teeth distance in toothing intervals.

20 mm; r = 140



16 mm; r = 95



13 mm; r = 65



10 mm; r = 40



8 mm; r = 30



6 mm; r = 16



4 mm; r = 8



3 mm; r = 3



New saw bands can tend to vibrate and make noises by sawing. It can be reduced by a small reduction of the cutting speed. For cutting small workpiece dimensions the saw blade could be retracted by about 300 cm<sup>2</sup> of the cutting material. For processing large workpieces, we recommend to retract over a period about 15 min. After leveling you can slowly increase the heading on the previously calculated value.

## TOOTH PITCH

The number of teeth per inch (TPI) is described as a tooth pitch. 1 inch complies 25,4 mm. A distinction is made between constant tooth pitch with uniform tooth spacing and variable tooth pitch with different tooth spacing within a toothing interval. Variable tooth spacing is identified by two measures, e.g. 2-3 TPI. 2 TPI identifies the max. tooth spacing and 3 TPI identifies the min. tooth spacing in the toothing interval.

### constant

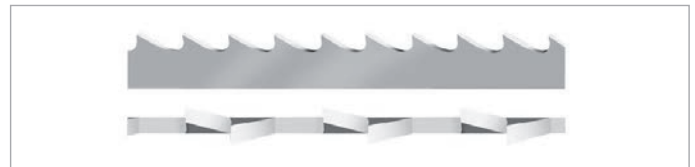

### variable







# BI-METALL COMBI

## SAW BANDS

Saw Bands

Description	Dimensions	EAN	Item No.
for BS 125 GS	1.440 x 13 x 0,65 mm 14 ZpZ Bi-Metall	4260364293814	533 1250
for BS 125 GS	1.440 x 13 x 0,65 mm 6-10 ZpZ Bi-Metall	4260364293821	533 1245
for BS 125 GS	1.440 x 13 x 0,65 mm 8-12 ZpZ Bi-Metall	4260364293838	531 1250
for BS 125 GS	1.440 x 13 x 0,65 mm 10-14 ZpZ Bi-Metall	4260364293845	532 1250
for BS 128 DG	1.638 x 13 x 0,65 mm 14 ZpZ Bi-Metall	4260364293852	532 2814
for BS 128 DG	1.638 x 13 x 0,65 mm 10-14 ZpZ Bi-Metall	4260364293869	533 2810
for BS 151 GS - old length	1.735 x 13 x 0,9 mm 14 ZpZ Bi-Metall	4260364293876	532 1514
for BS 151 GS - old length	1.735 x 13 x 0,9 mm 4 ZpZ Bi-Metall	4260364293883	533 1445
for BS 151 GS - new length	1.785 x 13 x 0,9 mm 4 ZpZ Bi-Metall	4260364293937	536 1503
for BS 151 GS - old length	1.735 x 13 x 0,9 mm 6 ZpZ Bi-Metall	4260364293890	533 1450
for BS 151 GS - new length	1.785 x 13 x 0,9 mm 6 ZpZ Bi-Metall	4260364293968	536 1506
for BS 151 GS - new length	1.785 x 13 x 0,9 mm 8-12 ZpZ Bi-Metall	4260364294088	536 1508
for BS 151 GS - old length	1.735 x 13 x 0,9 mm 10-14 ZpZ Bi-Metall	4260364293920	533 1510
for BS 151 GS - new length	1.785 x 13 x 0,9 mm 10-14 ZpZ Bi-Metall	4260364294170	536 1514
for BS 180 / BS 180 G	2.360 x 20 x 0,9 mm 8-12 ZpZ Bi-Metall	4260364293944	533 1812
for BS 180 / BS 180 G	2.360 x 20 x 0,9 mm 10-14 ZpZ Bi-Metall	4260364293951	533 1810
for BS 210 - old length	2.085 x 20 x 0,9 mm 4 ZpZ Bi-Metall	4260364293975	533 1910
for BS 210 - old length	2.085 x 20 x 0,9 mm 4-6 ZpZ Bi-Metall	4260364293982	533 1920
for BS 210 - new length	2.110 x 20 x 0,9 mm 4-6 ZpZ Bi-Metall	4260364294217	536 1920
for BS 210 - old length	2.085 x 20 x 0,9 mm 6-10 ZpZ Bi-Metall	4260364293999	533 1930
for BS 210 - new length	2.110 x 20 x 0,9 mm 6-10 ZpZ Bi-Metall	4260364297270	536 1930
for BS 210 - old length	2.085 x 20 x 0,9 mm 8-12 ZpZ Bi-Metall	4260364294002	532 1710
for BS 210 - new length	2.110 x 20 x 0,9 mm 8-12 ZpZ Bi-Metall	4260364297287	536 1710
for BS 210 - old length	2.085 x 20 x 0,9 mm 10-14 ZpZ Bi-Metall	4260364294019	533 1715
for BS 210 - new length	2.110 x 20 x 0,9 mm 10-14 ZpZ Bi-Metall	4260364297294	536 1715
for BS 230 V	3.035 x 27 x 0,9 mm 4-6 ZpZ Bi-Metall	4260364294033	533 2304
for BS 230 V	3.035 x 27 x 0,9 mm 5-8 ZpZ Bi-Metall	4260364297317	533 2305
for BS 230 V	3.035 x 27 x 0,9 mm 6-10 ZpZ Bi-Metall	4260364297324	533 2306
for BS 230 V	3.035 x 27 x 0,9 mm 8-12 ZpZ Bi-Metall	4260364294026	533 2308
for BS 230 V	3.035 x 27 x 0,9 mm 10-14 ZpZ Bi-Metall	4260364294040	533 2310
for BS 230 VG	3.230 x 27 x 0,9 mm 6-10 ZpZ Bi-Metall	4260364294057	531 2310
for BS 230 VG	3.230 x 27 x 0,9 mm 8-12 ZpZ Bi-Metall	4260364294064	532 2310
for BS 230 VG	3.230 x 27 x 0,9 mm 10-14 ZpZ Bi-Metall	4260364294071	533 2300
for BS 275 / BS 280	2.480 x 27 x 0,9 mm 4-6 ZpZ Bi-Metall	4260364294095	533 2730
for BS 275 / BS 280	2.480 x 27 x 0,9 mm 5-8 ZpZ Bi-Metall	4260364294101	533 2758
for BS 275 / BS 280	2.480 x 27 x 0,9 mm 6-10 ZpZ Bi-Metall	4260364294118	533 2740
for BS 275 / BS 280	2.480 x 27 x 0,9 mm 8-12 ZpZ Bi-Metall	4260364294125	531 2708
for BS 275 / BS 280	2.480 x 27 x 0,9 mm 10-14 ZpZ Bi-Metall	4260364294132	533 2710
for BS 279 G / GF	2.460 x 27 x 0,9 mm 8-12 ZpZ Bi-Metall	4260364294156	532 2610
for BS 279 G / GF	2.460 x 27 x 0,9 mm 10-14 ZpZ Bi-Metall	4260364294163	533 2615
for BS 350 DG / DGH / DGHF	2.925 x 27 x 0,9 mm 2-3 ZpZ Bi-Metall	4260364294224	533 3500
for BS 350 DG / DGH / DGHF	2.925 x 27 x 0,9 mm 3-4 ZpZ Bi-Metall	4260364294231	533 3502
for BS 350 DG / DGH / DGHF	2.925 x 27 x 0,9 mm 4-6 ZpZ Bi-Metall	4260364294248	533 3504
for BS 350 DG / DGH / DGHF	2.925 x 27 x 0,9 mm 6-10 ZpZ Bi-Metall	4260364294255	531 3504
for BS 350 DG / DGH / DGHF	2.925 x 27 x 0,9 mm 8-12 ZpZ Bi-Metall	4260364294262	533 3512
for E-BS 230 DG / DGH / V	2.730 x 27 x 0,9 mm 4-6 ZpZ Bi-Metall	4260364295351	632 3006
for E-BS 230 DG / DGH / V	2.730 x 27 x 0,9 mm 6-10 ZpZ Bi-Metall	4260364295368	632 3010
for E-BS 230 DG / DGH / V	2.730 x 27 x 0,9 mm 10-14 ZpZ Bi-Metall	4260364295375	632 3014
for E-BS 270 DG / DGH	3.160 x 27 x 0,9 mm 4-6 ZpZ Bi-Metall	4260364295382	632 7006
for E-BS 270 DG / DGH	3.160 x 27 x 0,9 mm 6-10 ZpZ Bi-Metall	4260364295399	632 7010
for E-BS 270 DG / DGH	3.160 x 27 x 0,9 mm 10-14 ZpZ Bi-Metall	4260364295405	633 7014



# BI-METALL COMBI

## SAW BANDS

Description	Dimensions	EAN	Item No.
for E-BS 320 / H / V / GV	3.660 x 27 x 0,9 mm 4-6 ZpZ Bi-Metall	4260364294873	632 2006
for E-BS 320 / H / V / GV	3.660 x 27 x 0,9 mm 5-8 ZpZ Bi-Metall	4260364294880	632 2008
for E-BS 320 / H / V / GV	3.660 x 27 x 0,9 mm 6-10 ZpZ Bi-Metall	4260364294897	632 2010
for E-BS 320 / H / V / GV	3.660 x 27 x 0,9 mm 10-14 ZpZ Bi-Metall	4260364294903	632 2014
for E-BS 320 L / HL / VL / GVL	4.160 x 34 x 1,1 mm 4-6 ZpZ Bi-Metall	4260364294958	632 2106
for E-BS 320 L / HL / VL / GVL	4.160 x 34 x 1,1 mm 5-8 ZpZ Bi-Metall	4260364294965	632 2108
for E-BS 320 L / HL / VL / GVL	4.160 x 34 x 1,1 mm 6-10 ZpZ Bi-Metall	4260364294972	632 2110
for E-BS 325 GV / GH	4.380 x 34 x 1,1 mm 4-6 ZpZ Bi-Metall	4260364294910	633 2006
for E-BS 325 GV / GH	4.380 x 34 x 1,1 mm 5-8 ZpZ Bi-Metall	4260364294927	633 2008
for E-BS 325 GV / GH	4.380 x 34 x 1,1 mm 6-10 ZpZ Bi-Metall	4260364294934	633 2010
for E-BS 360 DGH ECO	4.800 x 34 x 1,1 mm 4-6 ZpZ Bi-Metall	4260364294996	633 2106
for E-BS 360 DGH ECO	4.800 x 34 x 1,1 mm 5-8 ZpZ Bi-Metall	4260364295002	633 2108
for E-BS 360 DGH ECO	4.800 x 34 x 1,1 mm 6-10 ZpZ Bi-Metall	4260364295019	633 2110
for E-BS 360 DGH	5.000 x 34 x 1,1 mm 4-6 ZpZ Bi-Metall	4260364295033	632 2306
for E-BS 360 DGH	5.000 x 34 x 1,1 mm 5-8 ZpZ Bi-Metall	4260364295040	632 2308
for E-BS 360 DGH	5.000 x 34 x 1,1 mm 6-10 ZpZ Bi-Metall	4260364295057	632 2310
for E-BS 440 DGH / V / E-BS 360 GV	5.200 x 34 x 1,1 mm 4-6 ZpZ Bi-Metall	4260364295118	632 2406
for E-BS 440 DGH / V / E-BS 360 GV	5.200 x 34 x 1,1 mm 5-8 ZpZ Bi-Metall	4260364295125	632 2408
for E-BS 440 DGH / V / E-BS 360 GV	5.200 x 34 x 1,1 mm 6-10 ZpZ Bi-Metall	4260364295132	632 2410
for E-BSP 440 DGH	5.200 x 41 x 1,3 mm 4-6 ZpZ Bi-Metall	4260364295194	632 3406
for E-BSP 440 DGH	5.200 x 41 x 1,3 mm 5-8 ZpZ Bi-Metall	4260364295200	632 3408
for E-BSP 440 DGH	5.200 x 41 x 1,3 mm 6-10 ZpZ Bi-Metall	4260364295217	632 3410
for E-BSP 440 GV	5.400 x 41 x 1,3 mm 4-6 ZpZ Bi-Metall	4260364295071	633 2306
for E-BSP 440 GV	5.400 x 41 x 1,3 mm 5-8 ZpZ Bi-Metall	4260364295088	633 2308
for E-BSP 440 GV	5.400 x 41 x 1,3 mm 6-10 ZpZ Bi-Metall	4260364295095	633 2310
for E-BSP 540 GH	6.000 x 41 x 1,3 mm 4-6 ZpZ Bi-Metall	4260364295412	632 4006
for E-BSP 540 GH	6.000 x 41 x 1,3 mm 6-10 ZpZ Bi-Metall	4260364295429	632 4010
for E-BSP 560 DGH	6.800 x 41 x 1,3 mm 4-6 ZpZ Bi-Metall	4260364295443	632 6006
for E-BSP 560 DGH	6.800 x 41 x 1,3 mm 6-10 ZpZ Bi-Metall	4260364295450	632 6010
for E-BS 810 GH	8.200 x 41 x 1,3 mm 4-6 ZpZ Bi-Metall	4260364295156	633 2406
for E-BS 810 GH	8.200 x 41 x 1,3 mm 2-3 ZpZ Bi-Metall	4260364295163	633 2403
for E-BS 810 GH	8.200 x 41 x 1,3 mm 3-4 ZpZ Bi-Metall	4260364295170	633 2404
for E-BS 810 GH	8.200 x 41 x 1,3 mm 4-5 ZpZ Bi-Metall	4260364295187	633 2405
for E-BS 820 V	8.200 x 54 x 1,6 mm 4-6 ZpZ Bi-Metall	4260364295231	633 3406
for E-BS 820 V	8.200 x 54 x 1,6 mm 2-3 ZpZ Bi-Metall	4260364295245	633 3403
for E-BS 820 V	8.200 x 54 x 1,6 mm 3-4 ZpZ Bi-Metall	4260364295252	633 3404
for E-BS 820 V	8.200 x 54 x 1,6 mm 4-5 ZpZ Bi-Metall	4260364295269	633 3405
for E-BSP 650 DGH NC	8.400 x 54 x 1,6 mm 2-3 ZpZ Bi-Metall	4260364295276	632 5603
for E-BSP 650 DGH NC	8.400 x 54 x 1,6 mm 3-4 ZpZ Bi-Metall	4260364295283	632 5604
for E-BSP 650 DGH NC	8.400 x 54 x 1,6 mm 4-6 ZpZ Bi-Metall	4260364295290	632 5606
for E-BS 1.020 H	9.500 x 54 x 1,6 mm 4-6 ZpZ Bi-Metall	4260364295313	633 5606
for E-BS 1.020 H	9.500 x 54 x 1,6 mm 2-3 ZpZ Bi-Metall	4260364295320	633 5603
for E-BS 1.020 H	9.500 x 54 x 1,6 mm 3-4 ZpZ Bi-Metall	4260364295337	633 5604
for E-BS 1.020 H	9.500 x 54 x 1,6 mm 4-5 ZpZ Bi-Metall	4260364295344	633 5605
for E-BS 1.110 H	10.500 x 67 x 1,6 mm 1,5-2 ZpZ Bi-Metall	4260364297263	633 2202
for E-BS 1.110 H	10.500 x 67 x 1,6 mm 2-3 ZpZ Bi-Metall	4260364297270	633 2203
for E-BS 1.110 H	10.500 x 67 x 1,6 mm 3-4 ZpZ Bi-Metall	4260364297287	633 2204
for E-BS 1.110 HL	10.900 x 67 x 1,6 mm 1,5-2 ZpZ Bi-Metall	4260364297300	633 3502
for E-BS 1.110 HL	10.900 x 67 x 1,6 mm 2-3 ZpZ Bi-Metall	4260364297317	633 3503
for E-BS 1.110 HL	10.900 x 67 x 1,6 mm 3-4 ZpZ Bi-Metall	4260364297324	633 3504
for E-BS 1.313 H	12.100 x 67 x 1,6 mm 1,5-2 ZpZ Bi-Metall	4260364297348	633 6502
for E-BS 1.313 H	12.100 x 67 x 1,6 mm 2-3 ZpZ Bi-Metall	4260364297355	633 6503
for E-BS 1.313 H	12.100 x 67 x 1,6 mm 3-4 ZpZ Bi-Metall	4260364297362	633 6504
for E-BS 1.515 H	13.300 x 80 x 1,6 mm 2-3 ZpZ Bi-Metall	4260364297294	633 6603
for E-BS 1.515 H	13.300 x 80 x 1,6 mm 1,5-2 ZpZ Bi-Metall	4260364297331	633 6602
for E-BS 1.515 H	13.300 x 80 x 1,6 mm 1,1-1,6 ZpZ Bi-Metall	4260364297379	633 6601

MINIMUM PURCHASE 3 PCS.

MORE SAW BANDS ON REQUEST.

DRILLING  
MILLING  
TURNING  
SAWING  
GRINDING  
BENDING  
CUTTING / PRESSING  
OTHER MACHINES  
ACCESSORIES

# KKS 315 L / KKS 315 SA

## CIRCULAR COLD SAWS



PIC: KKS 315 L



PIC: head for slitting  
90° pivoted



PIC: KKS 315 SA  
SEMI-AUTOMATIC  
COLD CIRCULAR SAW

### KKS 315 L / KKS 315 SA

- » 2-step motor
- » electric coolant pump
- » gear head for slitting pivoting 90° to the right (see small illustration) and 30° to the left
- » automatically opening safety saw blade protection cover
- » vice with parallel tensioning and four separately adjustable vice jaws
- » vice jaws horizontally adjustable for the best possible material clamping during mitre cuts
- » base with integrated coolant device
- » pneumatic vice (only KKS 315 SA)

### OPTIONAL ACCESSORIES

- » coolant emulsion

**Model KKS 350 on request**

Description	KKS 315 L	KKS 315 SA
blade size	max. 315 mm	max. 315 mm
saw blade hole	40 mm	40 mm
head rotation	90° right, 30° left	±90°
cutting range at 90° circular	100 mm	70 mm
cutting range at 90° square	100 x 100 mm	90 x 80 mm
cutting range at 90° rect.	140 x 90 mm	70 x 70 mm
cutting range at 45° circular	90 mm	70 mm
cutting range at 45° square	90 x 90 mm	70 x 70 mm
cutting range at 45° rect.	100 x 90 mm	80 x 70 mm
vice opened	145 mm	140 mm
speed	18 / 36 min <sup>-1</sup>	19 / 38 min <sup>-1</sup>
motor power	400 V / 50 Hz 0,75 kW / 1,3 kW	400 V / 50 Hz 0,75 kW / 1,5 kW
dimensions (L x D x H)	800 x 550 x 1.700 mm	905 x 550 x 1.350 mm
inlet height	970 mm	930 mm
weight	227 kg	270 kg
	<b>KKS 315 L</b>	<b>KKS 315 SA</b>
<b>EAN</b>	<b>4260364290882</b>	<b>4260364290899</b>
<b>Item No.</b>	<b>240 1315</b>	<b>240 2315</b>

# E-MKS 315 / E-MKS 315 P / E-MKS 315 SA NC

## METAL CIRCULAR SAWS

**NEW**

**PREMIUM-LINE**

**E-MKS 315** (MANUAL MACHINE)  
**E-MKS 315 P** (MANUAL MACHINE WITH PNEUMATIC VICE)  
**E-MKS 315 SA NC** (SEMI-AUTOMATIC MACHINE WITH PNEUMATIC VICE)

- » 2-step motor
- » drive 400 V, 50 Hz
- » activation 24 V
- » gearhead can be swivelled by  $\pm 45^\circ$
- » automatically opening safety saw blade protective hood
- » substructure
- » microspray device (E-MKS 315 SA NC)

**OPTIONAL ACCESSORIES**

- » speed range lower
- » coolant emulsion
- » coolant system with tank
- » concentrate for coolant system
- » roller conveyer
- » saw blades



Description	E-MKS 315	E-MKS 315 P	E-MKS 315 SA NC
blade size	315 mm	315 mm	315 mm
saw blade hole	32 mm	32 mm	32 mm
head rotation	$\pm 45^\circ$	$\pm 45^\circ$	$\pm 45^\circ$
cutting range at 0° circular	105 mm	105 mm	105 mm
cutting range at 0° square	85 x 85 mm	85 x 85 mm	85 x 85 mm
cutting range at 0° rect.	120 x 70	120 x 70	120 x 70
cutting range at 45° circular	90 mm	90 mm	90 mm
cutting range at 45° square	80 x 80 mm	80 x 80 mm	80 x 80 mm
cutting range at 45° rect.	90 x 60 mm	90 x 60 mm	90 x 60 mm
vice opened	120 mm	120 mm	120 mm
speed	45 / 90 min <sup>-1</sup>	45 / 90 min <sup>-1</sup>	45 / 90 min <sup>-1</sup>
motor power	1,5 / 1,9 kW	1,5 / 1,9 kW	1,5 / 1,9 kW
dimensions (L x D x H)	700 x 1.200 x 1.350 mm	700 x 1.200 x 1.350 mm	700 x 1.200 x 1.350 mm
inlet height	1.200 mm	1.200 mm	1.200 mm
weight	190 kg	190 kg	210 kg
	<b>E-MKS 315</b>	<b>E-MKS 315 P</b>	<b>E-MKS 315 SA NC</b>
<b>EAN</b>	4260364298246	4260364298253	4260364298260
<b>Item No.</b>	340 1315	340 3315	340 2315

DRILLING  
MILLING  
TURNING  
SAWING  
GRINDING  
BENDING  
CUTTING / PRESSING  
OTHER MACHINES  
ACCESSORIES



# E-KKS-MZ 315 NC

CIRCULAR SAW WITH AUTOMATIC  
MATERIAL FEED AND PLC-CONTROL

**NEW**

**PREMIUM-LINE**



## E-KKS-MZ 315 NC

- » machine for straight saw cuts with servo-controlled material feed
- » hydropneumatic operation of saw head allows a smooth lowering for an optimal cut
- » two speeds
- » PLC-control
- » coloured touch screen
- » up to four cutting lengths per part
- » cut positioning  $\pm 0,3$  mm
- » coolant tank and pump included

## OPTIONAL ACCESSORIES

- » roller block
- » saw blade
- » roller conveyors



PIC: OPTIONAL ROLLER CONVEYOR WITH FEED AND DIGITAL DISPLAY

Description	E-KKS-MZ 315 NC
saw blade diameter	315 mm
saw blade bore	32 mm
cutting capacity 90° circular	100 mm
cutting capacity 90° square	80 x 80 mm
cutting capacity 90° rectangular	110 x 80 mm
speeds	40 / 80 min <sup>-1</sup>
motor power	400 V / 50 Hz / 3 kW
dimensions (L x D x H)	1.900 x 1.350 x 1.400 mm
weight	620 kg
	<b>E-KKS-MZ 315 NC</b>
<b>EAN</b>	<b>4260364298529</b>
<b>Item No.</b>	<b>340 0315</b>

**Saw blade is not included in scope of delivery.**

# E-KKS-MZ 350 V

## CIRCULAR SAW WITH AUTOMATIC MATERIAL FEED AND PLC-CONTROL



### E-KKS-MZ 350 V

- » machine for straight saw cuts with servo-controlled material feed
- » hydropneumatic operation of saw head allows a smooth lowering for an optimal cut
- » speed range is stepless
- » PLC control for 200 cutting programs
- » coloured touch screen
- » up to four cutting lengths per part
- » cut positioning  $\pm 0,2$  mm
- » coolant tank and pump included

### OPTIONAL ACCESSORIES

- » bundle loading device
- » roller block
- » saw blade
- » roller conveyors



PIC: OPTIONAL ROLLER CONVEYOR WITH FEED AND DIGITAL DISPLAY

Description	E-KKS-MZ 350 V
saw blade diameter	350 mm
saw blade bore	32 mm
cutting capacity 90° circular	110 mm
cutting capacity 90° square	100 x 100 mm
cutting capacity 90° rectangular	120 x 90 mm
speeds	20 - 100 min <sup>-1</sup>
motor power	400 V / 50 Hz / 5,6 kW
dimensions (L x D x H)	2.200 x 1.100 x 2.000 mm
weight	1.370 kg
<b>E-KKS-MZ 350 V</b>	
<b>EAN</b>	<b>4260657651444</b>
<b>Item No.</b>	<b>340 0350</b>

DRILLING

MILLING

TURNING

SAWING

GRINDING

BENDING

CUTTING / PRESSING

OTHER MACHINES

ACCESSORIES

# E-VKKS 350 / E-VKKS 400

CIRCULAR SAWS WITH VERTICAL GUIDANCE OF THE  
SAW HEAD

**PREMIUM-LINE**

**NEW**



- E-VKKS 350 / E-VKKS 400**
- » semi-automatic vertical circular saw
  - » hardened vertical guides
  - » hydropneumatic feed for even saw cut
  - » foot pedal
  - » saw head with heavy-duty worm gearbox
  - » stepless speed adjustment (only model E-VKKS 400)
  - » mitre setting from -45° up to +60°
  - » with coolant device and chip container

Circular Saws

Description	E-VKKS 350	E-VKKS 400
saw blade diameter	350 mm	400 mm
saw blade bore	32 mm	40/50 mm
cutting capacity 90° circular	110 mm	120 mm
cutting capacity 90° square	90 x 90 mm	110 x 110 mm
cutting capacity 90° rectangular	160 x 90 mm	160 x 90 mm
cutting capacity 45° circular	110 mm	120 mm
cutting capacity 45° square	90 x 90 mm	100 x 100 mm
cutting capacity 45° rectangular	120 x 80 mm	120 x 90 mm
cutting capacity 60° circular	90 mm	90 mm
cutting capacity 60° square	80 x 80 mm	90 x 90 mm
cutting capacity 60° rectangular	80 x 80 mm	90 x 90 mm
speeds	36 / 72 min <sup>-1</sup>	20 - 70 min <sup>-1</sup>
motor power	400 V / 50 Hz / 3,1 kW	400 V / 50 Hz / 3,1 kW
dimensions (L x D x H)	1.000 x 800 x 1.800 mm	1.202 x 1.085 x 1.758 mm
weight	480 kg	540 kg
	<b>E-VKKS 350</b>	<b>E-VKKS 400</b>
<b>EAN</b>	<b>4260364298505</b>	<b>4260364298512</b>
<b>Item No.</b>	<b>340 1350</b>	<b>340 1400</b>

**OPTIONAL ACCESSORIES**

» roller blocks



» roller conveyors



» saw blades



# E-KKS 350-80 V / E-KKS 360-100 V

## FULLY AUTOMATIC CIRCLE SAWS

NEW

PREMIUM-LINE

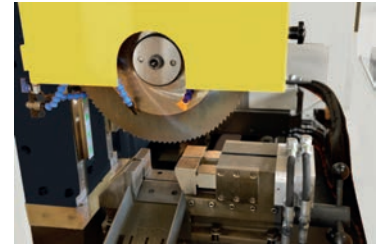

PIC: E-KKS 360-100 V WITH OPTIONAL ROLLER CONVEYOR

### E-KKS 350-80 V / E-KKS 360-100 V

- » sawing head with very stable vertical guide, prevents vibration of the saw blade
- » stepless vertical feed 20 - 100 m/min
- » material guidance by servo motor, infeed accuracy +/-0,05 to 0,1 mm (per stroke)
- » transmission design for maximum service life sawing
- » material feed is designed for slight parallelism to compensate
- » intuitive and user-friendly operation with touch screen
- » possibility to program several cutting lengths per part
- » safety covers for maximum operator protection and comfort

Description	E-KKS 350-80 V	E-KKS 360-100 V
cutting performance circular	20 - 80 mm	20-100 mm
opening vice	max. 85 mm	max. 105 mm
material feed path max.	500 mm	800 mm
saw blade speed	20 - 100 m/min	40 - 200 m/min
saw blade diameter	260 - 350 x 2.0 - 3,0 mm (max.)	360 x 2,7 mm
working height	900 mm	800 mm
motor power	5,5 kW	11 kW
servo motor Feed	1,0 kW	2,0 kW
dimensions (L x D x H)	1.700 x 1.600 x 2.170 mm	2.460 x 2.460 x 2.610 mm
weight	1.425 kg	3.450 kg
	<b>E-KKS 350-80 V</b>	<b>E-KKS 360-100 V</b>
<b>EAN</b>	<b>4260364296174</b>	<b>4260364299939</b>
<b>Item No.</b>	<b>340 2350</b>	<b>340 2360</b>

#### OPTIONAL ACCESSORIES

- » The material feed table enables continuous cutting



# AKS 400

## ALUMINUM CIRCULAR SAW

Aluminium Saws



### AKS 400

- » semi-automatic cutting machine for cutting of aluminum and aluminum alloys: solid material and profiles
- » stable and strong construction
- » simple and easy operation
- » precise cut
- » rotating saw head 60° to the left and 45° to the right
- » 2 pneumatic quick action vices with PTFE coated jaws



PIC: WITH ROLLER CONVEYOR LEFT AND RIGHT OPTIONAL

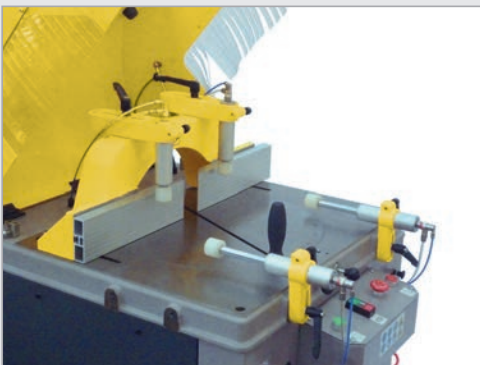

Description	AKS 400
blade size	420 x 30 mm
head rotation	-60° up to +45°
cutting range at 90° circular	90 mm
cutting range at 90° square	120 x 120 mm
cutting range at 90° rectangular	200 x 110 mm
cutting range at 45° circular	80 mm
cutting range at 45° square	110 x 110 mm
cutting range at 45° rectangular	150 x 100 mm
speed	3.000 min <sup>-1</sup>
motor power	400 V / 50 Hz / 2,2 kW
dimensions (L x D x H)	1.000 x 970 x 1.500 mm
weight	275 kg
	<b>AKS 400</b>
EAN	4260364290929
Item No.	241 0400

	Roller Conveyor for AKS 400 left / right
EAN	4260364297300
Item No.	532 0403

# E-UAKS 400 / E-UAKS 450 / E-UAKS 550

## ALUMINUM CIRCULAR SAWS

**NEW**

**PREMIUM-LINE**

### E-UAKS 400 / E-UAKS 450 E-UAKS 550

- » Semi-automatic machine for the cutting of solid material and profiles in aluminum and light alloys
- » stable and strong construction
- » simple and easy operation
- » precise cut
- » mitre in both directions
- » 2 pneumatic quick action vices with PTFE coated jaws

### OPTIONAL VERSION

sensitive cut regulation  
(Model **E-UAKS 450 SR** and **E-UAKS 550 SR**) on request.



PIC: E-UAKS 450

Description	E-UAKS 400	E-UAKS 450	E-UAKS 550
blade size	400 x 32 mm	450 x 32 mm	550 x 32 mm
head rotation	-45° up to +45°	-45° up to +45°	-45° up to +45°
cutting range at 90° circular	120 mm	130 mm	155 mm
cutting range at 90° square	120 x 120 mm	130 x 130 mm	155 x 155 mm
cutting range at 90° rectangular	150 x 110 mm	210 x 170 mm	260 x 200 mm
cutting range at 45° circular	100 mm	100 mm	130 mm
cutting range at 45° square	100 x 100 mm	100 x 100 mm	130 x 130 mm
cutting range at 45° rectangular	130 x 80 mm	145 x 170 mm	180 x 200 mm
speed	3.000 min <sup>-1</sup>	3.000 min <sup>-1</sup>	3.000 min <sup>-1</sup>
motor power	400 V / 50 Hz / 3 kW	400 V / 50 Hz / 2,2 kW	400 V / 50 Hz / 3 kW
dimensions (L x D x H)	720 x 760 x 1.330 mm	850 x 950 x 1.350 mm	980 x 1.130 x 1.430 mm
weight	132 kg	180 kg	200 kg
	<b>E-UAKS 400</b>	<b>E-UAKS 450</b>	<b>E-UAKS 550</b>
<b>EAN</b>	<b>4260364298284</b>	<b>4260364298536</b>	<b>4260364298543</b>
<b>Item No.</b>	<b>340 0400</b>	<b>340 0450</b>	<b>340 0550</b>

## E-AKS 2L-420 / E-AKS 2L-450 / E-AKS 2L-500

### DOUBLE MITRE ALUMINUM CIRCULAR SAWS

**PREMIUM-LINE**

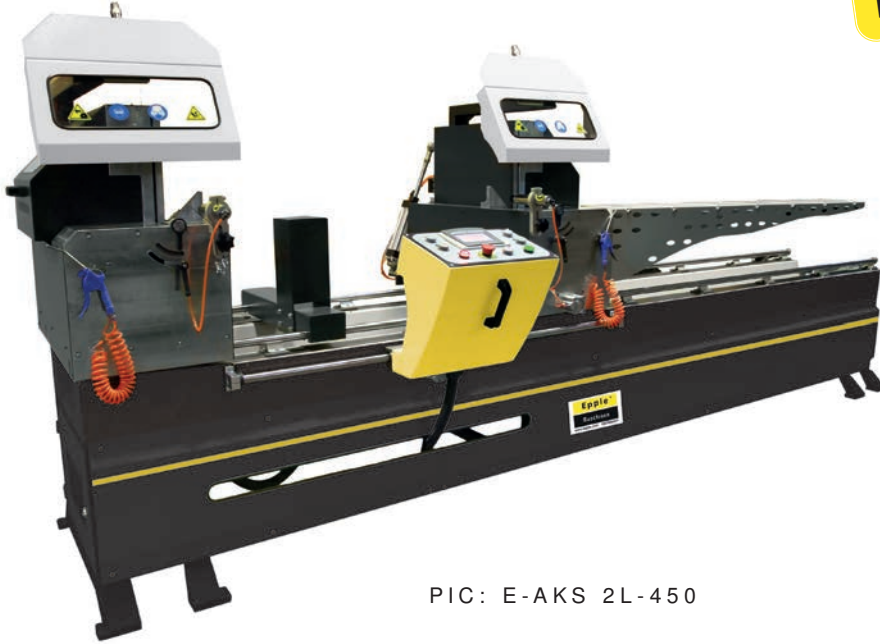

PIC: E-AKS 2L-450

#### E-AKS 2L-420 / E-AKS 2L-450 / E-AKS 2L-500

Universal circular saw for aluminium, light metal and plastic, with two mitre-tilting working heads. Workpieces can not only be sawn to length, but also simultaneously mitred at both ends. Workpiece clamping (profiles) can be clamped pneumatically.

Delivery without saw blades, order according to the application.

Description	E-AKS 2L-420	E-AKS 2L-450	E-AKS 2L-500
blade size	420 x 32 x 4 mm	450 x 32 x 4 mm	500 x 32 x 4 mm
max. sawing height	100 mm	120 mm	160 mm
head rotation	-45° up to +45°	-45° up to +45°	-45° up to +45°
cutting range at 90° circular	100 mm	135 mm	150 mm
cutting range at 90° square	100 x 100 mm	135 x 135 mm	150 x 150 mm
cutting range at 90° rectangular	100 x 160 mm	100 x 200 mm	100 x 220 mm
cutting range at 45° circular	100 mm	120 mm	130 mm
cutting range at 45° square	100 x 100 mm	120 x 120 mm	130 x 130 mm
cutting range at 45° rectangular	110 x 100 mm	100 x 140 mm	100 x 160 mm
min. cut	480 mm	540 mm	540 mm
max. cut	3.450 mm	3.450 mm	3.450 mm
speed	3.000 min <sup>-1</sup>	3.000 min <sup>-1</sup>	3.000 min <sup>-1</sup>
motor power	400 V / 50 Hz / 1,5 kW	400 V / 50 Hz / 2,2 kW	400 V / 50 Hz / 2,2 kW
dimensions (L x D x H)	6.000 x 1.680 x 1.170 mm	6.000 x 1.680 x 1.170 mm	6.000 x 1.680 x 1.170 mm
weight	800 kg	900 kg	900 kg
	<b>E-AKS 2L-420</b>	<b>E-AKS 2L-450</b>	<b>E-AKS 2L-500</b>
<b>EAN</b>	<b>4260364298550</b>	<b>4260364297850</b>	<b>4260364298567</b>
<b>Item No.</b>	<b>340 2420</b>	<b>340 2450</b>	<b>340 2500</b>

# TM 350 / E-TM 350 PROFI

## CUTTING MACHINES



PIC: TM 350

### TM 350 / E-TM 350 PROFI

- » stationary cutting machine with cutting disc for solid materials and profiles
- » solid and forceful construction
- » easy to operate
- » turnable saw head 45° to the left & right
- » main switch and load protection
- » control handle with security switch
- » TM 350 for rough workshop operation, model Profi also for laboratory workshops

### OPTIONAL ACCESSORIES

- » Model PROFI with extensibilities
- » roller block
- » roller conveyor

Description	TM 350	E-TM 350 PROFI
cut-off wheel diameter	350 mm	350 mm
head rotation	±45°	±45°
cutting range at 90° circular	120 mm	120 mm
cutting range at 90° square	120 x 120 mm	120 x 120 mm
cutting range at 90° rectangular	80 x 120 mm	80 x 120 mm
cutting range at 45° circular	105 mm	105 mm
cutting range at 45° square	105 x 105 mm	105 x 105 mm
cutting range at 45° rectangular	90 x 100 mm	90 x 100 mm
vice opened	190 mm	190 mm
speed	4.300 min <sup>-1</sup>	4.300 min <sup>-1</sup>
motor power	400 V / 50 Hz / 4 kW	400 V / 50 Hz / 4 kW
dimensions (L x D x H)	860 x 640 x 1.690 mm	970 x 620 x 1.700 mm
inlet height	890 mm	890 mm
weight	145 kg	230 kg
	<b>TM 350</b>	<b>E-TM 350 PROFI</b>
<b>EAN</b>	<b>4260364290912</b>	<b>4260364298574</b>
<b>Item-No.</b>	<b>241 0350</b>	<b>341 0350</b>



# VBS 300 / VBS 400 / VBS 500 / VBS 585

## VERTICAL BAND SAWS



PIC: VBS 500

- » user-friendly vertical band saw for metal
- » table swivelable -45° to the right and -15° to the left
- » infinitely variable cutting speed
- » adjustable tape guide
- » tape cutting device
- » tape welding device
- » tape grinding machine
- » LED working light

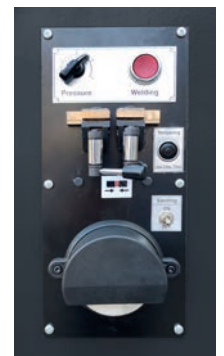

Vertical Band Saws

Description	VBS 300	VBS 400	VBS 500	VBS 585
table size	400 x 500 mm	550 x 600 mm	660 x 700 mm	660 x 700 mm
space between stand-saw band	300 mm	400 mm	500 mm	585 mm
max. workpiece height	185 mm	285 mm	310 mm	336 mm
cutting speed	0 - 1.400 min <sup>-1</sup>	0 - 1.400 min <sup>-1</sup>	0 - 1.400 min <sup>-1</sup>	0 - 1.400 min <sup>-1</sup>
saw band length	2.865 - 2.920 mm	3.390 - 3.467 mm	3.980 - 4.050 mm	4.430 - 4.520 mm
sawband height	3 - 16 mm	3 - 16 mm	3 - 16 mm	6 - 19 mm
motor power	400 V / 50 Hz / 0,55 kW	400 V / 50 Hz / 1,5 kW	400 V / 50 Hz / 1,5 kW	400 V / 50 Hz / 1,5 kW
dimensions (L x D x H)	960 x 650 x 1.750 mm	1.080 x 800 x 2.000 mm	1.400 x 900 x 2.200 mm	1.470 x 950 x 2.300 mm
weight	275 kg	310 kg	484 kg	555 kg
	<b>VBS 300</b>	<b>VBS 400</b>	<b>VBS 500</b>	<b>VBS 585</b>
<b>EAN</b>	<b>4260657651932</b>	<b>4260364296143</b>	<b>4260364296150</b>	<b>4260364296167</b>
<b>Item No.</b>	<b>241 1300</b>	<b>241 1400</b>	<b>241 0500</b>	<b>241 0585</b>



# Grinding

# DS 150 / DS 175 / DS 200-400 V

## DOUBLE ENDED GRINDERS



PIC: DS 175

Grinding Machines

### DS 150 / DS 175 / DS 200-400 V

- » solid quality double ended grinder for the professional machining of work parts of metal
- » adequate for long-term work
- » massive stable construction with maintenance free electro motors
- » aluminium casting body
- » high smoothness and longevity by balanced rotor with quality ball bearings
- » protection of flying sparks by 2 makrolon covers
- » adjustable and massive work part plating
- » scope of supply: 2 universal aluminium oxide abrasive wheel

Description	DS 150	DS 175	DS 200-400 V
dimensions of grinding disk / bore	Ø 150 x 20, Ø 16 mm	Ø 175 x 20, Ø 32 mm	Ø 200 x 25, Ø 32 mm
speed	2.850 min <sup>-1</sup>	2.850 min <sup>-1</sup>	2.850 min <sup>-1</sup>
motor power	230 V / 0,50 kW	230 V / 0,50 kW	400 V / 0,90 kW
dimensions (L x D x H)	410 x 200 x 295 mm	420 x 220 x 300 mm	450 x 245 x 330 mm
weight	16 kg	18 kg	27 kg
	<b>DS 150</b>	<b>DS 175</b>	<b>DS 200-400 V</b>
<b>EAN</b>	4260364290936	4260364290943	4260364290950
<b>Item No.</b>	226 2150	226 2175	226 2200

# ISM 250 / ISM 250 F

## COMBINED GRINDING AND POLISHING MACHINES



PIC: ISM 250



PIC: ISM 250 F

### ISM 250 / ISM 250 F

- » **stepless speed adjustment** (ISM 250 F)
- » fast and easy deburring and/or polishing even of complex profiles
- » powerful pulling power due to powerful motor
- » uncomplicated, tool-free grinding belt replacement
- » substructure with lockable door
- » tool compartment included in scope of delivery
- » individually swivelling grinding arm with suction connection
- » suitable for grinding, polishing and brushing metal, plastic and non-ferrous metals such as e.g. copper, bronze, aluminum, brass, etc.

Description	ISM 250	ISM 250 F
dimensions of grinding belt	75 x 1.500 mm	50 x 2.000 mm
dimensions grinding disc	250 x 32 x 25 mm	250 x 50 mm
speed	1.100 / 2.300 min <sup>-1</sup> (2 steps)	200 - 2.800 min <sup>-1</sup> (stepless)
motor power	400 V / 50 Hz / 1,5 kW	400 V / 50 Hz / 2,2 kW
dimensions (L x D x H)	830 x 630 x 1.280 mm	1.160 x 700 x 1.850 mm
weight	75 kg	150 kg
	<b>ISM 250</b>	<b>ISM 250 F</b>
<b>EAN</b>	<b>4260364297775</b>	<b>4260364294385</b>
<b>Item No.</b>	<b>225 9001</b>	<b>225 9000</b>



# TBSM 100-2 2 BELT SPEEDS BSM 75 / BSM 75-2 WITH 2-SPEED MOTOR / BSM 75 A METAL BELT GRINDERS



PIC: TBSM 100-2  
NOT SWIVELABLE



PIC: BSM 75 A  
WITH INTEGRATED  
DUST COLLECTOR

Metal Belt Grinders

## TBSM 100-2 / BSM 75 / BSM 75-2 / BSM 75 A

Description	Stand for TBSM 100-2
EAN	4260364296075
Item No.	525 0102

- » 2 speed motor BSM 75-2
- » vibration free running
- » quick adjustment into horizontal / vertical position
- » continuously surface grinding area by opening the cover
- » quick sanding belt tension
- » powerful motor 3 kW
- » fast tension for the grinding belt
- » **time-safing deburring**

Description	TBSM 100-2	BSM 75	BSM 75-2	BSM 75 A
belt size	100 x 1.220 mm	75 x 2.000 mm	75 x 2.000 mm	75 x 2.000 mm
contact wheel	-	200 x 75 mm	200 x 75 mm	200 x 75 mm
belt speed	9,5 m/sec / 19 m/sec	34 m/sec	17 m/sec / 34 m/sec	33 m/sec
grinding rest	100 mm continous	75 mm continous	75 mm continous	75 mm continous
motor power	400 V / 50 Hz / 1,5 kW	400 V / 50 Hz / 3 kW	400 V / 50 Hz / 2,2 kW / 2,8 kW	400 V / 50 Hz / 4 kW
dimensions (W x D x H)	355 x 432 x 410 mm	450 x 1.000 x 1.100 mm	450 x 1.000 x 1.100 mm	620 x 1.000 x 1.130 mm
weight	44 kg	85 kg	107 kg	107 kg
	<b>TBSM 100-2</b>	<b>BSM 75</b>	<b>BSM 75-2</b>	<b>BSM 75 A</b>
EAN	4260364296181	4260364290967	4260364290974	4260657650409
Item No.	225 5102	225 5075	225 6075	225 7075

# BSM 150 / BSM 150-2 WITH 2-SPEED MOTOR BSM 150 A / BSM 220 METAL GRINDERS

NEW



PIC: BSM 150



PIC: BSM 220

## BSM 150 / BSM 150-2 / BSM 150 A / BSM 220

- » 2 speed motor (BSM 150-2)
- » vibration free running
- » quick adjustment into horizontal / vertical position
- » continuously surface grinding area by opening the cover

- » quick sanding belt tension
- » powerful motor
- » fast tension for the grinding belt
- » integrated dust collector (BSM 150 A)

Description	BSM 150	BSM 150-2	BSM 150 A	BSM 220
belt size	150 x 2.000 mm	150 x 2.000 mm	150 x 2.000 mm	220 x 2.000 mm
contact wheel	250 x 150 mm	250 x 150 mm	250 x 150 mm	200 x 220 mm
belt speed	37 m/sec	18 / 37 m/s	33 m/sec	29 m/s
grinding rest	150 mm continous	150 mm continous	150 mm continous	220 mm continous
motor power	400 V / 50 Hz / 3 kW	400 V / 50 Hz 2,3 kW / 3 kW	400 V / 50 Hz / 4 kW	400 V / 50 Hz / 3 kW
dimensions (W x D x H)	500 x 1.000 x 1.100 mm	500 x 1.000 x 1.100 mm	500 x 1.000 x 1.100 mm	640 x 980 x 1.030 mm
weight	124 kg	124 kg	135 kg	118 kg
	<b>BSM 150</b>	<b>BSM 150-2</b>	<b>BSM 150 A</b>	<b>BSM 220</b>
<b>EAN</b>	4260364290981	4260364290998	4260657650416	4260364296198
<b>Item No.</b>	225 5150	225 6150	225 7150	225 5220

# E-BTSM 50 / E-VBSM 60 / E-HBSM 75

## BAND GRINDING MACHINES



PIC: E-BTSM 50



PIC: E-HBSM 75



PIC: E-VBSM 60

### E-BTSM 50 / E-VBSM 60

- » combination of belt grinder and disc grinder
- » light and easy to transport
- » enables chamfering, deburring and polishing (E-VBSM 60)

### E-HBSM 75

- » 3 interchangeable rollers allow to grind contours
- » high belt speed
- » vibrationless operation
- » surfaces and contours can be grinded by a combination of sanding belt and different deflection rollers

Description	E-BTSM 50	E-VBSM 60	E-HBSM 75
band dimension	50 x 1.000 mm	75 x 1.750 mm	75 x 1.500 mm
motor power	0,75 kW	0,75 kW	1,1 kW
dimensions (W x D x H)	550 x 450 x 350 mm	800 x 400 x 450 mm	460 x 750 x 450 mm
weight	25 kg	42 kg	80 kg
	E-BTSM 50	E-VBSM 60	E-HBSM 75
EAN	4260657651451	4260657651468	4260657651475
Item No.	325 5050	325 5060	325 5075

# KRBS 100

## TUBE GRINDER

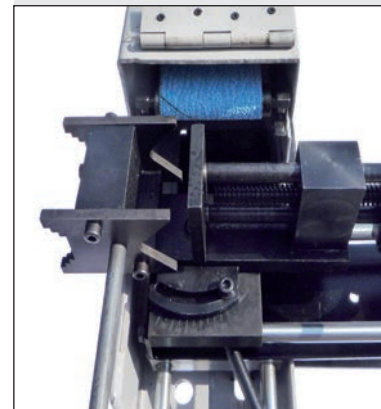
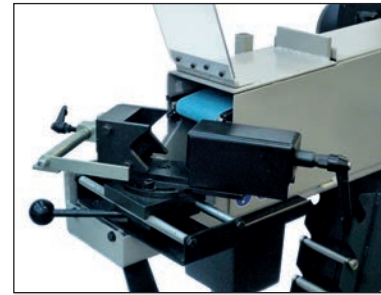

Roller Sets	Item No.
ø 20 mm	625 6020
ø 26 mm	625 6026
ø 32 mm	625 6032
ø 42 mm	625 6042
ø 48 mm	625 6048
ø 60 mm	625 6060
ø 76 mm	625 6076

### KRBS 100

- » for grinding tubes and profiles on the front side, face grinding on the upper side and burring grinding on the back
- » adjustable grinding angle 30° - 90°
- » quick change between pipe grinding and band grinding
- » a powerful clamping device guarantees excellent grinding results
- » standard grinding belt with 36 grit
- » powerful motor
- » nearly all adjustments accomplishable without tool
- » with integrated grinding roll holder for optionally available grinding rolls with different diameters
- » with pivotable protection glass
- » tool for maintenance included in scope of delivery
- » two belt speeds - for grinding steel and stainless steel
- » with two chip trays
- » integrated connecting piece for metal exhausters
- » easily removeable chip trays

#### Scope of delivery KRBS 100:

- » 1x standard grinding band with graining K 36
- » 2x chip trays
- » 1x screw wrench
- » 1x grinding roll

Description	KRBS 100
belt size	100 x 2.000 mm
belt speed	15 / 30 m/sec.
grindable diameter	20 - 76,1 mm
adjustable grinding angle	30° - 90°
motor power	400 V / 50 Hz / 2,8 kW
speed	1.400 / 2.800 min <sup>-1</sup>
dimensions (W x D x H)	520 x 1.175 x 1.130 mm
weight	158 kg
<b>KRBS 100</b>	
EAN	4260364294408
Item No.	225 7202



**E-KRBS 100-90 / E-KRBS 100-170**  
TUBE GRINDING MACHINE

**NEW**

**PREMIUM-LINE**



PIC: E-KRBS 100-90  
CLOSED AND OPENED

**E-KRBS 100-90 / E-KRBS 100-170**

Conveniently operated pipe and profile grinding machine

- » adjustable grinding angle up to 50°
- » quick clamping device
- » easy to change rollers for different grinding diameter
- » standard grinding belt with grain size K36
- » powerful motor

**Scope of delivery:**

- » 1 pcs. of standard grinding belt, grain size K36
- » 6 pcs. of grinding belt pressure roller

Description	E-KRBS 100-90	E-KRBS 100-170
belt size	100 x 2.000 mm	200 x 1.400 mm
grindable diameter	17 - 90 mm	40 - 170 mm
adjustable grinding angle	max. 50°	max. 50°
motor power	400 V / 50 Hz / 2,2 kW	400 V / 50 Hz / 3 kW
dimensions (B x D x H)	1.150 x 600 x 1.000 mm	1.550 x 850 x 1.300 mm
weight	170 kg	350 kg
	<b>E-KRBS 100-90</b>	<b>E-KRBS 100-170</b>
<b>EAN</b>	<b>4260364298581</b>	<b>4260364298598</b>
<b>Item No.</b>	<b>325 9010</b>	<b>325 1710</b>

# E-RSM 76 / E-RSM 114

## PIPE-GRINDING AND POLISHING MACHINE

**PREMIUM-LINE**



PIC: E-RSM 76



PIC: E-RSM 114



FEED UNIT E-RSM 114

### E-RSM 76 / E-RSM 114

- » for grinding round and oval pipes, rectangular tubes only with the E-RSM 114
- » stepless adjustable speed of grinding belt
- » two opposite running grinding belts on the rotating head, the rotation of the workpiece is not required (E-RSM 76 a band)

Only for the E-RSM 114

- » foot pedal to control the rotation head
- » profile is fed with hand wheel in feed unit stretched
- » feed unit with rubber rollers ensures a safe transport of the workpiece
- » uniform deburring, cleaning or polishing of tubes
- » automatic feed

Description	E-RSM 76	E-RSM 114
no. of belts	1	2
tube diameter	10 - 76 mm	10 - 114 mm
min. tube length	355 mm	355 mm
belt speed	22 m/s	3 - 22 m/s
belt size	735 x 30 mm	940 x 50 mm
motor power	400 V / 2,2 kW	400 V / 4,75 kW
dimensions (W x D x H)	800 x 750 x 1.300 mm	750 x 1.000 x 1.300 mm
weight	165 kg	265 kg
	<b>E-RSM 76</b>	<b>E-RSM 114</b>
EAN	4260657650423	4260364296204
Item No.	354 1078	354 1114

# E-VFSM 150

## MANUAL SURFACE GRINDING MACHINE

# Surface Grinding Machines



PIC: E-VFSM 150 WITH ELECTRO-MAGNETIC CLAMPING PLATE

Surface grinding machines with fixed table:

- » stable construction for high rigidity
- » coolant system
- » grinding head is moved manually
- » height adjustment by hand wheel

### OPTIONAL ACCESSORIES

- » permanent magnet clamping plate
- » electromagnetic clamping plate (not retrofittable)
- » rotating plate with magnet
- » LED machine light

Description	E-VFSM 150
max distance grinding wheel - table	138 mm
grinding wheel	150 x 90 x 80 mm
vertical feed value	0,025 mm
spindle taper	80 mm
table size	200 x 120 mm
motor power	400 V / 50 Hz / 1,5 kW
motor speed	1.400 min-1
dimensions (W x D x H)	560 x 470 x 670 mm
weight	80 kg
	<b>E-VFSM 150</b>
<b>EAN</b>	<b>4260657650102</b>
<b>Item No.</b>	<b>325 7315</b>

# HFSM 4020 / HFSM 5025 / HFSM 6030 / HFSM 8040

NEW

## FLAT- AND SURFACE GRINDING MACHINE



PIC: HFSM 4020



PIC: HFSM 6030

### HFSM 4020 / HFSM 5025 / HFSM 6030 / HFSM 8040

Surface grinding machines with convenient operation for precise and economical workpiece machining. All models are designed for long-term continuous operation, from model HFSM 5025 with longitudinal and transverse feed and automatic vertical feed.

With standard accessories grinding wheel flange, balancing mandrel, coolant container, working lamp, tool box, grinding wheel dresser without diamond, standard grinding wheel, levelling feet.

In order to grind profiles, the grinding wheel must be given a corresponding contour. There are various extra options for this. More details on request (please specify desired profile shape).

#### OPTIONAL ACCESSORIES

- » extraction device
- » coolant device with filter belt
- » balancing scale
- » parallel dresser
- » grinding wheel flange

Description	HFSM 4020	HFSM 5025	HFSM 6030	HFSM 8040
grinding length max.	470 mm	560 mm	765 mm	910 mm
grinding width max.	220 mm	275 mm	340 mm	450 mm
table size	450 x 210 mm	500 x 250 mm	635 x 305 mm	810 x 405 mm
distance: table and spindle	450 mm	450 mm	580 mm	580 mm
vertical feed	manual	automatic 6 steps	automatic 6 steps	automatic 6 steps
table feed	manual	automatic 7 - 23 m/min	automatic 7 - 23 m/min	automatic 7 - 23 m/min
grinding wheel size	200 x 31 x 13 mm	200 x 31 x 13 mm	350 x 127 x 40 mm	350 x 127 x 40 mm
spindle speeds	2.850 min <sup>-1</sup>	2.850 min <sup>-1</sup>	1.450 min <sup>-1</sup>	1.450 min <sup>-1</sup>
motor power	1,2 kW	2,2 kW	5,5 kW	5,5 kW
dimensions (L x T x H)	1.100 x 1.370 x 1.920 mm	2.250 x 2.050 x 2.130 mm	2.800 x 2.200 x 2.200 mm	3.600 x 2.400 x 2.200 mm
weight	approx. 800 kg	1.800 kg	2.800 kg	3.800 kg
	<b>HFSM 4020</b>	<b>HFSM 5025</b>	<b>HFSM 6030</b>	<b>HFSM 8040</b>
EAN	4260364297669	4260364297676	4260364297683	4260364297690
Item No.	227 0402	227 1502	227 1603	227 1804

DRILLING

MILLING

TURNING

SAWING

GRINDING

BENDING

CUTTING /  
PRESSING

OTHER  
MACHINES

ACCESSORIES



**PREMIUM-LINE**

# E-ZB BSM 2.100

## DOUBLE BELT GRINDER



### E-ZB BSM 2.100

Machine for pre- and fine grinding of surfaces, compensation of unevenness, of edges and welds of flat components made of steel, stainless steel and aluminum.

Large components can be fed from the front and from the back.

Applications are e.g. doors, frames, control cabinets, housings, hoods, furniture parts, frame parts in automotive and aircraft construction, apparatus housings, lamp housings, waste containers, radiators etc.

- » manually adjustable table
- » High work safety through self-contained system
- » LED work light
- » speed adjustment 0 - 3,000 min<sup>-1</sup>
- » pneumatic control system
- » rubber roller pressing system

Description	E-ZB BSM 2.100
belt size	min. 100 x 7.100 mm max. 100 x 7.200 mm
speed	0 - 3.000 min <sup>-1</sup>
motor power	400 V / 50 Hz / 4 kW
table size	2.100 x 800 mm
table elevation adjustment	600 mm
dimensions (L x D x H)	3.600 x 1.100 x 2.250 mm
weight	1.200 kg
	<b>E-ZB BSM 2.100</b>
<b>EAN</b>	<b>4260364294392</b>
<b>Item No.</b>	<b>340 5210</b>

**Other lengths available on request.**

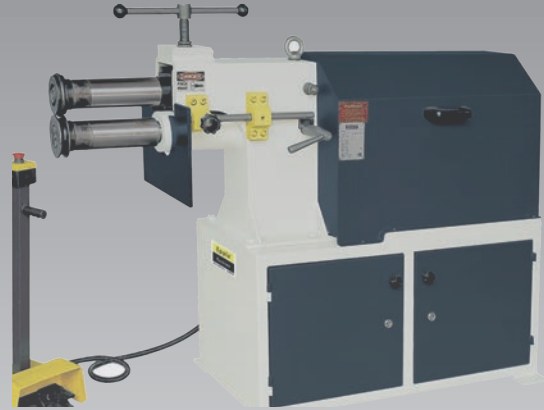

# Sheet Metal Forming Machines

# UB 40 / WB 100 / UBM

## UNIVERSAL- AND ANGLE-BENDER



PIC: WB 100



PIC: UB 40



PIC: UBM

Bending Machines

### WB 100

- » stable construction to mount directly onto the workbench
- » stepless adjustable bending stop
- » with eccentric quick tension for rational working
- » readable bend angle up to 120°
- » high repeat precision through bending angle stop
- » ideal for plumbers and repair workshops

### UB 40

- » to bend flat, square and round material
- » economic turn of usual shapes and bends
- » easily transportable, suitable for installation in service vehicles

### UBM

- » to bend angles, strips, round - and square materials
- » ideal for workshops and modelmakers
- » suitable to repair doors, balcony fence, steel brass and copper

Description	UB 40
bending capacity - strip steel	30 x 8 mm
bending capacity - round steel	15 mm
bending capacity - square steel	13 x 13 mm
max. bending capacity	40 kg/mm <sup>2</sup>
dimensions (L x D x H)	710 x 630 x 160 mm
weight	23 kg
	<b>UB 40</b>
<b>EAN</b>	<b>4260364291117</b>
<b>Item No.</b>	<b>225 0004</b>

Description	WB 100
flat steel	100 x 5 mm
round steel	20 mm
square steel	18 x 18 mm
angle steel	60 x 8 mm / 100 x 12 mm
flat steel	100 x 10 mm
round steel	30 mm
square steel	30 x 30 mm
angle steel	100 x 12 mm
max. bending capacity	40 kg/mm <sup>2</sup>
dimension (L x D x H)	910 x 205 x 255 mm
weight	29 kg
	<b>WB 100</b>
<b>EAN</b>	<b>4260364291124</b>
<b>Item No.</b>	<b>225 0010</b>

Description	UBM
strip steel - radius bend	8 x 50 mm
strip steel - sharp bend	6 x 50 mm
round steel	16 mm
square steel	6 x 16 mm
reinforced steel	12 mm
working height	960 - 1.200 mm
baseplate dimensions	240 x 240 mm
distance mounting holes	195 x 195 mm
weight	35 kg
	<b>UBM</b>
<b>EAN</b>	<b>4260364291131</b>
<b>Item No.</b>	<b>225 0100</b>

# RB 10 T / RBE 10 T

## HYDRAULIC PIPE BENDING MACHINES



PIC: RB 10 T



PIC: RBE 10 T



### RB 10 T / RBE 10 T

- » with folding bend frame for rational working
- » including 6 pulley sets 1/2", 3/4", 1", 1 1/4", 1 1/2" and 2"
- » universal applications for water, gas and boiler pipes
- » tripod stand for safe working
- » bends up to 90° reparable
- » pressure capacity up to 10 t
- » also suitable for copper and annealed pipes

### RBE 10 T

- » electric version  
230 V / 50 Hz

Description	RB 10 T	RBE 10 T
bending capacity	1/2" - 2"	1/2" - 2"
piston pressure	10 t	10 t
no. of pulley sets	6 pcs.	6 pcs.
stroke length	160 mm	160 mm
dimensions (L x D x H)	680 x 510 x 910 mm	680 x 510 x 680 mm
weight	42 kg	53 kg
	<b>RB 10 T</b>	<b>RBE 10 T</b>
<b>EAN</b>	<b>4260364291148</b>	<b>4260364291155</b>
<b>Item No.</b>	<b>225 0122</b>	<b>225 1122</b>



# HCP 30 / HCP 40 / HCP 50 NC

## PIPE BENDING MACHINES

**NEW**



PIC: HCP 30



PIC: HCP 40



PIC: HCP 50 NC

### HCP 30 / HCP 40 / HP 50 NC

- » for bending low-carbon round tubes, stainless steel tubes, square tubes and round steel
- » solid, stable construction for high efficiency
- » HCP 50 NC with hydraulic drive via NC-control and "One-touch" operation for single pieces, as well as program recall for mass production

### STANDARD

### MATRICES SET

- » HCP 30: 16, 26 and 32 mm
- » HCP 40: 16, 20, 25, 32 and 38 mm
- » HCP 50 NC: 25, 32, 38 and 48 mm

Description	HCP 30	HCP 40	HCP 50 NC
pipe diameter	12 - 30 mm	16 - 40 mm	16 - 51 mm
wall thickness	1 - 3 mm	1 - 3 mm	1 - 5 mm
bending radius	Dx3/4	Dx3/4	180°
motor power	manual	1,5 kW	2,2 kW
dimensions (L x W x H)	520 x 290 x 290 mm	780 x 540 x 770 mm	1.450 x 690 x 1.170 mm
weight	70 kg	220 kg	550 kg

	HCP 30	HCP 40	HCP 50 NC
<b>EAN</b>	<b>4260657651857</b>	<b>4260657651864</b>	<b>4260657651925</b>
<b>Item No.</b>	<b>262 0030</b>	<b>262 0040</b>	<b>262 0050</b>

# E-MRB 42 / E-MRB 60

## PIPE BENDING MACHINES

**NEW**



PIC: E-MRB 42



PIC: E-MRB 60

### E-MRB 42 / E-MRB 60

- » tube bending machines for mobile or stationary use with PLC control
- » up to 100 programs can be stored
- » 5 bends can be stored per part
- » automatic return to reference point
- » included in delivery is a pipe-forming tool with holder

### OPTIONAL ACCESSORIES

- » various forming tools
- » stand

Description	E-MRB 42	E-MRB 60
max. pipe diameter	42 mm	60 mm
bending max. radius	-	180° 250 mm
max. diameter steel	42 x 1,5 mm	60 x 3,0 mm
max. diameter stainless steel	30 x 2,0 mm	on request
max. diameter aluminum	42 x 3,0 mm	on request
max. diameter copper	42 x 1,5 mm	on request
motor power	manual	3,5 kW
dimensions (L x W x H)	520 x 170 x 350 mm	600 x 650 x 1.100 mm
weight	75 kg	170 kg

	E-MRB 42	E-MRB 60
<b>EAN</b>	<b>4260657650430</b>	<b>4260657650454</b>
<b>Item No.</b>	<b>362 0042</b>	<b>362 0060</b>

DRILLING

MILLING

TURNING

SAWING

GRINDING

BENDING

CUTTING / PRESSING

OTHER MACHINES

ACCESSORIES

# E-TBM 60 NC / E-TBM 76 NC

## TUBE BENDING MACHINES

**PREMIUM-LINE**



PIC: E-TBM 60 NC

Tube bending Machines

### E-TBM 60 NC / E-TBM 76 NC

- » solid welded construction
- » for pipes up to 60 x 4 mm
- » workbench with boreholes for holding tools
- » NC control with display
- » 500 programmes storable
- » standard accessories: roller burnishingtool

### OPTIONAL ACCESSORIES

- » burnishing tools for different pipe diameters

Description	E-TBM 60 NC	E-TBM 76 NC
diameter min.	R40 (Ø 16 x 4)	R40 (Ø 16 x 3)
diameter max.	R150 (Ø 60 x 4)	R220 (Ø 76 x 3)
bending capacity tubes	St 60 x 4 mm / Alu 60 x 8 mm	St 76 x 3 mm / Alu 76 x 6 mm
radius min	3x tube diameter	3x tube diameter
radius max	150 mm	220 mm
bending of full material	40 mm	45 mm
bending of square pipe	40 x 40 x 4 mm	50 x 50 x 5 mm
bending speed	3 m/min	7 m/min
motor power	2,2 kW	3 kW
dimensions (L x D x H)	850 x 750 x 1.050 mm	850 x 850 x 1.050 mm
weight	330 kg	500 kg
	<b>E-TBM 60 NC</b>	<b>E-TBM 76 NC</b>
<b>EAN</b>	<b>4260364296228</b>	<b>4260364296235</b>
<b>Item No.</b>	<b>351 3060</b>	<b>351 3076</b>

# E-RDBM 32 M / E-RDBM 32 H / E-RDBM 32 HD

TUBE BENDING MACHINES WITH MANDREL

**PREMIUM-LINE**

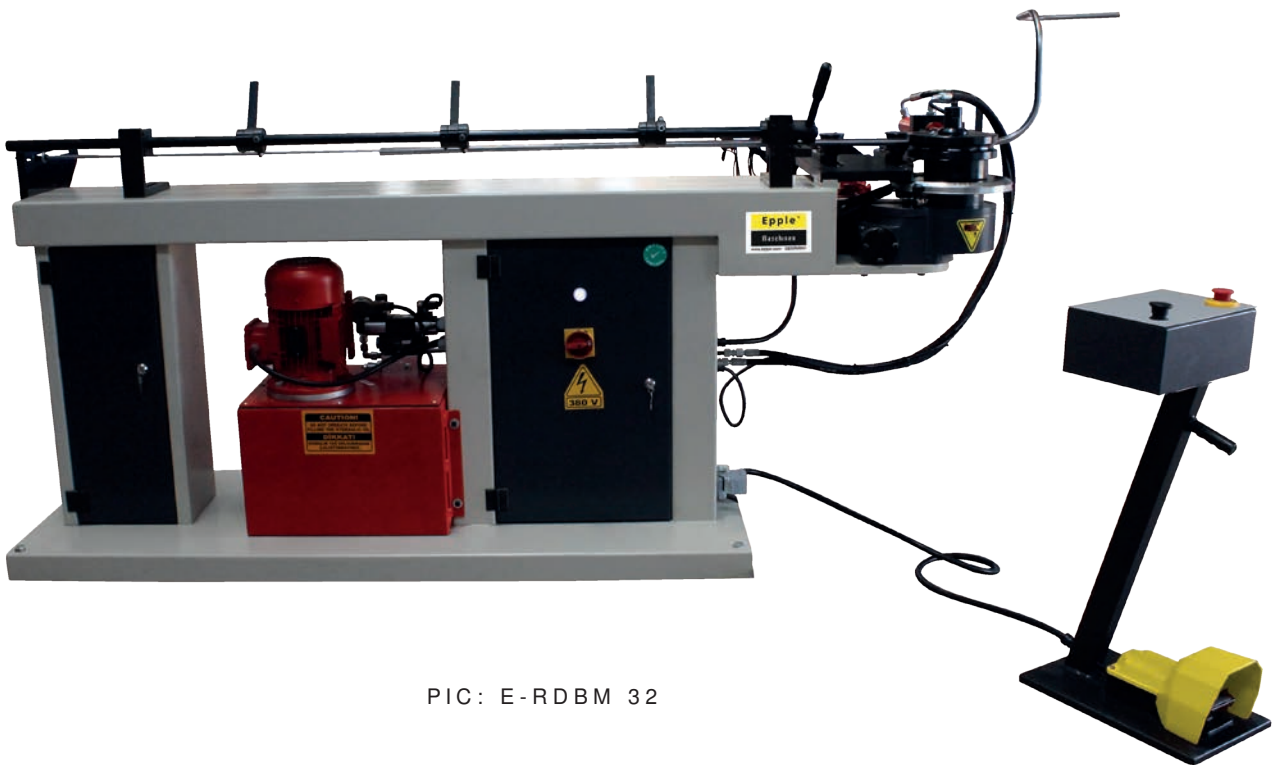

PIC: E-RDBM 32

## E-RDBM 32 M / E-RDBM 32 H / E-RDBM 32 HD

Mandrel bending machines in high quality for individual production up to medium lot sizes of thin-walled steel tubes, stainless steel, aluminium and non-ferrous metals.

Description	E-RDBM 32 M	E-RDBM 32 H	E-RDBM 32 HD
max. diameter	32 mm	32 mm	32 mm
max. bending radius	250 mm	250 mm	250 mm
max. bending angle	190°	190°	190°
working length	1.500 mm	2.100 mm	2.100 mm
max. hydraulic pressure	electric	50 - 220 bar	50 - 220 bar
motor power	2,2 kw	3,7 kW	3,7 kW
dimensions (L x D x H)	1.950 x 850 x 950 mm	2.200 x 1.200 x 1.000 mm	2.200 x 1.200 x 1.000 mm
weight	300 kg	350 kg	410 kg
	<b>E-RDBM 32</b>	<b>E-RDBM 32 H</b>	<b>E-RDBM 32 HD</b>
<b>EAN</b>	<b>4260657650485</b>	<b>4260657651772</b>	<b>4260657651789</b>
<b>Item No.</b>	<b>351 3132</b>	<b>351 4132</b>	<b>351 5132</b>



# E-RDBM NC-MODELS

## PIPE BENDING MACHINES WITH MANDREL

NEW

PREMIUM-LINE



PIC: E-RDBM 90 NC

### E-RDBM NC-MODELS

Modern mandrel bending machines in high quality with NC control for bending thin-walled tubes.

#### ACCESSORIES

- » 1 tool set (diameter on request)
- » mobile control panel with 10" touch screen
- » machine offers the possibility to bend with or without mandrel
- » NC control for 99 storable programs
- » operation automatically or manually possible
- » 20 bending steps are possible per program
- » quantity evaluation in the controller
- » mobile foot pedal with emergency stop
- » bending angle is measured via encoder
- » hydraulic mandrel feed (from E-RDBM 65 NC)
- » bending process hydraulic
- » hydraulic material clamping
- » control panel with key switch
- » overload protection

#### OPTIONALE ACCESSORIES

- » additional tools
- » manual feed with display
- » feed with servo drive
- » hydraulic feed (up to E-RDBM 51 NC)
- » laser light cut-off
- » mandrel lubrication system
- » oil preheating device
- » mandrel in different length



bending unit



hydraulic mandrel

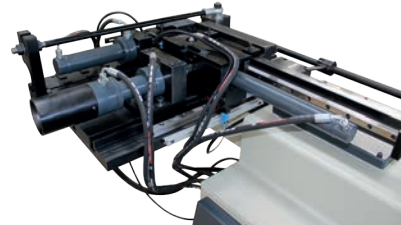

pipe feed

Description	E-RDBM 38 NC	E-RDBM 51 NC	E-RDBM 65 NC
max. pipe thickness	38 mm	51 mm	65 mm
max. wall thickness	3 mm	3 mm	4 mm
max. inner bending radius	250 mm	250 mm	250 mm
max. bending angle	190°	190°	190°
mandrel length	3.000 mm	3.000 mm	3.000 mm
max. hydraulic pressure	50-220 bar	50-220 bar	50-220 bar
motor power	5,5 kW	8 kW	16 kW
dimensions (L x W x H)	4.450 x 900 x 1.250 mm	4.750 x 1.200 x 1.300 mm	4.750 x 1.200 x 1.300 mm
weight	1.500 kg	2.600 kg	2.800 kg
	<b>E-RDBM 38 NC</b>	<b>E-RDBM 51 NC</b>	<b>E-RDBM 65 NC</b>
<b>EAN</b>	<b>4260657650508</b>	<b>4260657650515</b>	<b>4260657650522</b>
<b>Item No.</b>	<b>351 3238</b>	<b>351 3251</b>	<b>351 3265</b>

Description	E-RDBM 76 NC	E-RDBM 90 NC	E-RDBM 120 NC
max. pipe thickness	76 mm	90 mm	120 mm
max. wall thickness	4 mm	4 mm	6 mm
max. inner bending radius	250 mm	250 mm	300 mm
max. bending angle	190°	190°	190°
mandrel length	4.000 mm	4.000 mm	4.100 mm
max. hydraulic pressure	50-220 bar	50-220 bar	50-220 bar
motor power	16 kW	20 kW	30 kW
dimensions (L x W x H)	6.000 x 1.400 x 1.500 mm	1.400 x 6.100 x 1.550 mm	5.500 x 1.300 x 1.400 mm
weight	3.450 kg	2.900 kg	3.600 kg
	<b>E-RDBM 76 NC</b>	<b>E-RDBM 90 NC</b>	<b>E-RDBM 120 NC</b>
<b>EAN</b>	<b>4260657650492</b>	<b>4260657650539</b>	<b>4260657650546</b>
<b>Item No.</b>	<b>351 3276</b>	<b>351 3290</b>	<b>351 3212</b>

DRILLING

MILLING

TURNING

SAWING

GRINDING

BENDING

CUTTING / PRESSING

OTHER MACHINES

ACCESSORIES

## E-RDBM CNC-MODELS

### PIPE BENDING MACHINES WITH MANDREL

NEW

PREMIUM-LINE



PIC: E-RDBM 42 CNC

#### E-RDBM CNC-MODELS

Modern mandrel bending machines in high quality with NC control for bending thin-walled tubes.

#### ACCESSORIES

- » 1 tool set (diameter on request)
- » feed and bending movement via servo motor
- » mobile control panel with 21" touch screen
- » control with 3D simulation
- » workpiece length calculation
- » remote diagnosis
- » machine offers the possibility to work with or without mandrel to bend
- » NC control for 99 storable programs
- » operation automatically or manually possible
- » 20 bending steps are possible per program
- » quantity evaluation according to time in the control
- » mobile foot pedal with emergency stop
- » bending angle is measured via encoder
- » hydraulic mandrel feed (from E-RDBM 65 NC)
- » bending process hydraulic
- » hydraulic material clamping
- » control panel with key switch
- » overload protection
- » oil cooler
- » cooling system for the electrical system

#### OPTIONAL ACCESSORIES

- » additional tools
- » manual feed with display
- » feed with servo drive
- » hydraulic feed (up to E-RDBM 51 NC)
- » laser light cut-off
- » mandrel lubrication system
- » oil preheating device
- » mandrel in different length

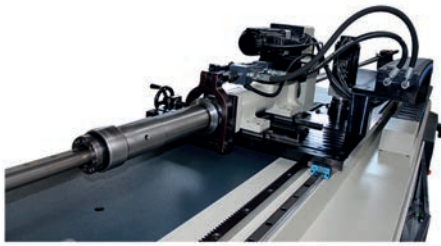

pipe feed



bending unit

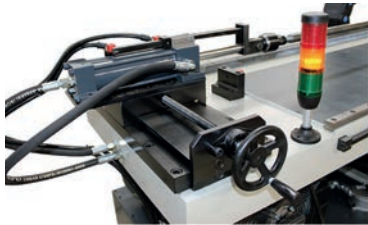

hydraulic mandrel



3D Simulation on screen

Description	E-RDBM 38 CNC	E-RDBM 51 CNC	E-RDBM 65 CNC
max. pipe thickness	38 mm	51 mm	65 mm
max. wall thickness	3 mm	3 mm	4 mm
max. inner bending radius	250 mm	250 mm	250 mm
max. bending angle	190°	190°	190°
mandrel length	3.000 mm	3.000 mm	3.000 mm
max. hydraulic pressure	220 bar	220 bar	220 bar
motor power	7,5 kW	13,5 kW	15,5 kW
dimensions (L x W x H)	4.280 x 1.000 x 1.500 mm	4.950 x 1.200 x 1.600 mm	4.950 x 1.250 x 1.600 mm
	<b>E-RDBM 38 CNC</b>	<b>E-RDBM 51 CNC</b>	<b>E-RDBM 65 CNC</b>
<b>EAN</b>	<b>4260657650553</b>	<b>4260657650577</b>	<b>4260657650584</b>
<b>Item No.</b>	<b>351 3338</b>	<b>351 3351</b>	<b>351 3365</b>

Description	E-RDBM 76 CNC	E-RDBM 90 CNC
max. pipe thickness	76 mm	90 mm
max. wall thickness	4 mm	4 mm
max. inner bending radius	300 mm	300 mm
max. bending angle	190°	190°
mandrel length	4.000 mm	4.000 mm
max. hydraulic pressure	220 bar	220 bar
motor power	23,5 kW	27,5 kW
dimensions (L x W x H)	5.800 x 1.550 x 1.750 mm	5.800 x 1.550 x 1.750 mm
	<b>E-RDBM 76 CNC</b>	<b>E-RDBM 90 CNC</b>
<b>EAN</b>	<b>4260657650560</b>	<b>4260657650591</b>
<b>Item No.</b>	<b>351 3376</b>	<b>351 3390</b>

DRILLING

MILLING

TURNING

SAWING

GRINDING

BENDING

CUTTING / PRESSING

OTHER MACHINES

ACCESSORIES



## SM 08 DEBURRING MACHINE MANUAL



standard roller sets



### SM 08 INCL. 6 ROLLER SETS

- » special steel shaft
- » to carry easily
- » heavy duty cast iron construction
- » adjustable bottom shaft
- » in order to produce of different pipe connections
- » swiveling machine body with table clamp device
- » standard with 6 different roll sets

### EXAMPLE OF USE

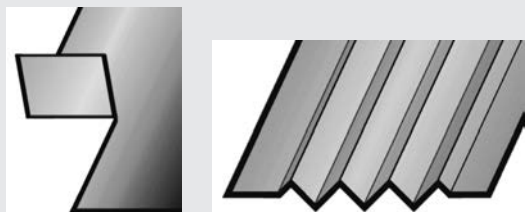
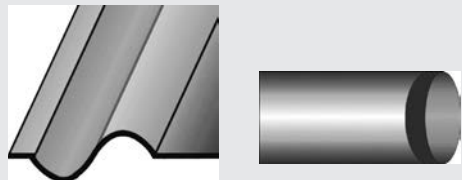
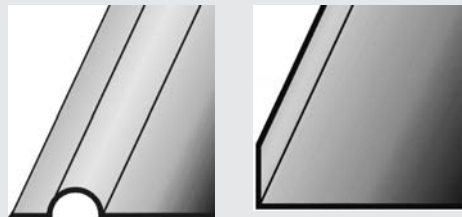

Description	SM 08
max. sheet thickness	0,8 mm
distance between roll centres	50 mm
working range	200 mm
depth	300 mm
length	515 mm
height	800 mm
weight	22 kg
	<b>SM 08</b>
<b>EAN</b>	<b>4260364291162</b>
<b>Item No.</b>	<b>225 1008</b>

# E-SM 12

## DEBURRING MACHINE MANUAL

**PREMIUM-LINE**

### STANDARD

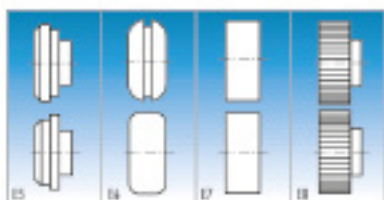
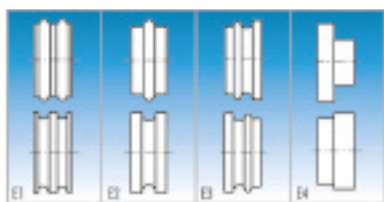
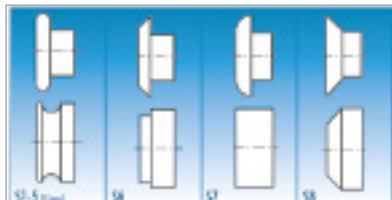

### E-SM 12

INCL. 8 ROLLER SETS

- » heavy duty cast iron construction
- » portable and easy to transport
- » 8 standard roll sets
- » special steel shaft
- » adjustable upper shaft

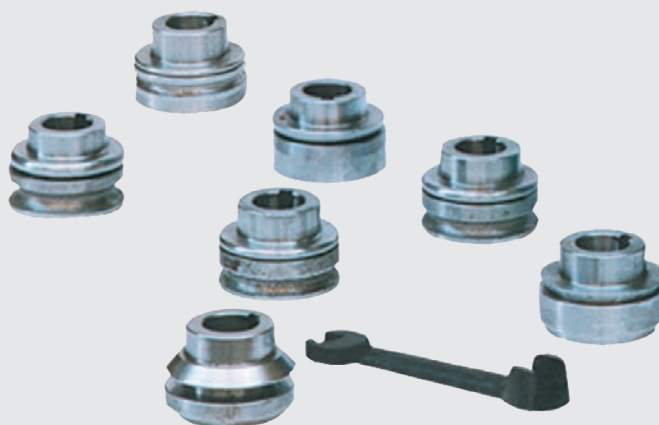

Description	E-SM 12
max. sheet thickness	1,2 mm
wave length	140 mm
roller diameter	62 mm
roller speed	-
working radius	100 mm
motor power	manual
dimensions (L x D x H)	560 x 220 x 500 mm
weight	50 kg
	<b>E-SM 12</b>
<b>EAN</b>	<b>4260364291179</b>
<b>Item No.</b>	<b>354 1210</b>

### EXAMPLE OF USE

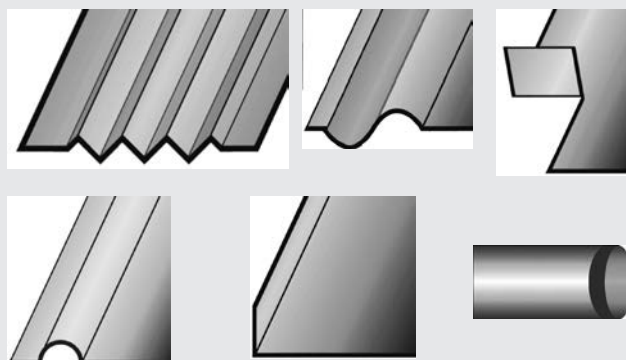

DRILLING

MILLING

TURNING

SAWING

GRINDING

BENDING

CUTTING / PRESSING

OTHER MACHINES

ACCESSORIES

## E-SM 12 MP ELECTRICAL DEBURRING MACHINES

**PREMIUM-LINE**



### STANDARD

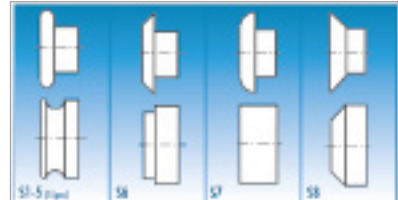

### OPTIONAL

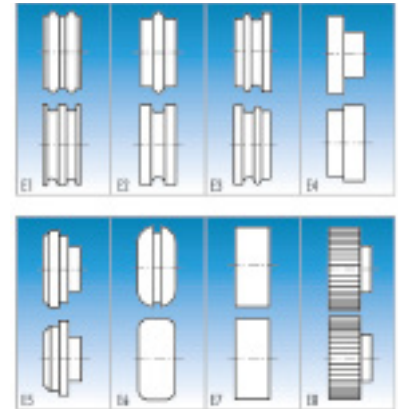

Description	E-SM 12 MP
max. sheet thickness	1,2 mm
wavelength	140 mm
roller diameter	62 mm
roller speed	32 min <sup>-1</sup>
working radius	100 mm
motor power	400 V / 0,75 kW
dimensions (L x D x H)	900 x 450 x 1.350 mm
weight	135 kg
<b>E-SM 12 MP</b>	
EAN	4260364291186
Item No.	354 1200

### E-SM 12 MP INCL. STAND

- » heavy duty cast iron construction
- » substructure
- » foot pedal
- » 8 standard roller sets
- » adjustable bottom shaft
- » self-braking motor

### EXAMPLE OF USE

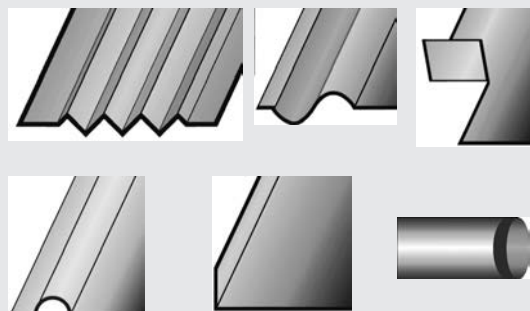

OPTIONAL  
MODEL E-SM 12-4 MP

» 4 speeds (30, 60, 90, 120 min<sup>-1</sup>)

# E-SM 25 MP

## DEBURRING MACHINES

**PREMIUM-LINE**



PIC: DIAMETER 2,5



PIC: E-SM 25 MP

### E-SM 25 MP INCL. STAND

- » heavy duty cast iron construction
- » base frame and base cabinet
- » freely movable foot pedal, thus remains free hands for material guidance
- » 8 standard roll sets
- » forward and backward adjustment
- » self-braking motor

#### OPTIONAL-ROLLERS FOR E-SM 25 MP

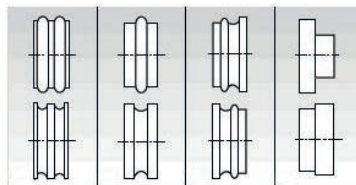

#### STANDARD-ROLLERS FOR E-SM 25 MP

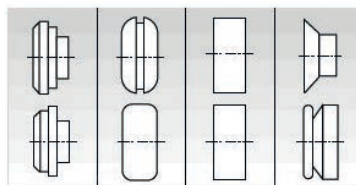
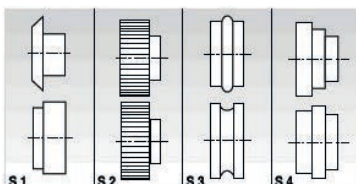

Description	E-SM 25 MP
max. sheet thickness	2,5 mm
wavelengths	250 mm
roller diameter	96 mm
roller speed	5 m/min
working range	160 mm
motor power	400 V / 1,5 kW
dimensions (L x D x H)	1.400 x 550 x 1.120 mm
weight	350 kg

	E-SM 25 MP
<b>EAN</b>	<b>4260364296266</b>
<b>Item No.</b>	<b>354 2500</b>

DRILLING

MILLING

TURNING

SAWING

GRINDING

BENDING

CUTTING /  
PRESSING

OTHER  
MACHINES

ACCESSORIES



# E-SM 40 MP

## DEBURRING MACHINE

**PREMIUM-LINE**



PIC: E-SM 40 MP

Deburring Machine

### E-SM 40 MP INCL. STAND

- » heavy duty cast iron construction
- » base frame and base cabinet
- » freely movable foot pedal, thus remains free hands for material guidance
- » steel tool shank with bronze bearing
- » 4 standard roll sets
- » forward and backward adjustment
- » self-braking motor

### OPTIONAL ACCESSORIES

- » digital Readout System for upper tools
- » roller sets for different profiles (see examples on page 167)
- » hydraulic infeed for the top roller

Description	E-SM 40 MP
max. sheet thickness	4,0 mm
wavelength	300 mm
roller diameter	126 mm
roller speed	5 m/min
working range	200 mm
motor power	400 V / 2,2 kW
dimensions (L x D x H)	1.700 x 570 x 1.200 mm
weight	500 kg
<b>E-SM 40 MP</b>	
<b>EAN</b>	<b>4260364296273</b>
<b>Item No.</b>	<b>354 4000</b>

### STANDARD-ROLLERS FOR E-SM 40 MP

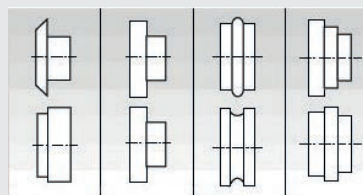

### OPTIONAL-ROLLERS FOR E-SM 40 MP

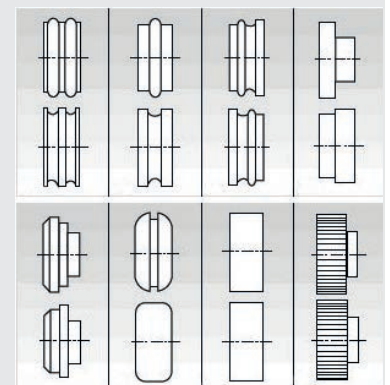

# ROLL SETS

## DEBURRING MACHINES

### E-SM 12 / E-SM 12 MP

#### STANDARD

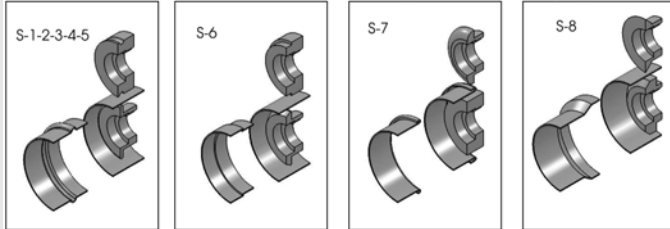

#### OPTIONAL

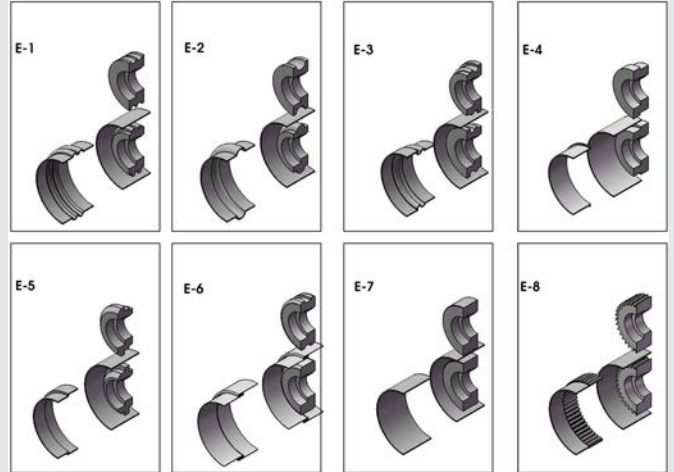

### E-SM 25 MP

#### STANDARD

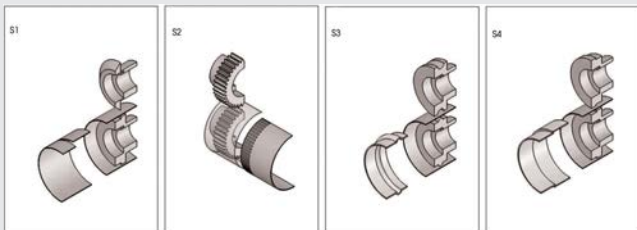

#### OPTIONAL

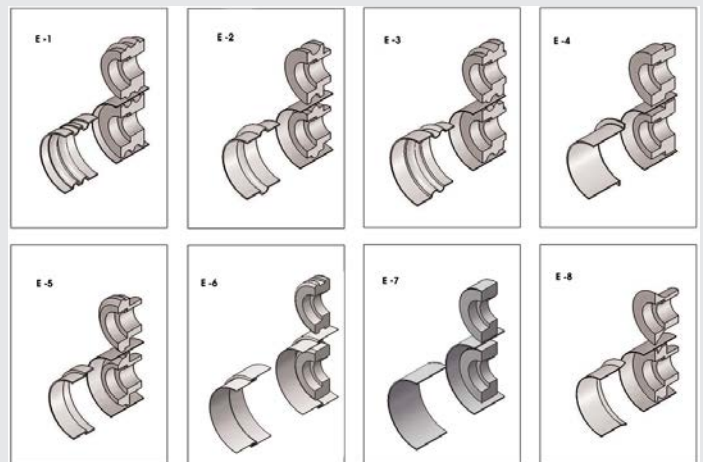

### E-SM 40 MP

#### STANDARD

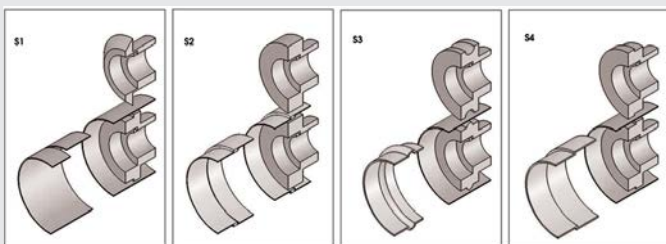

#### OPTIONAL

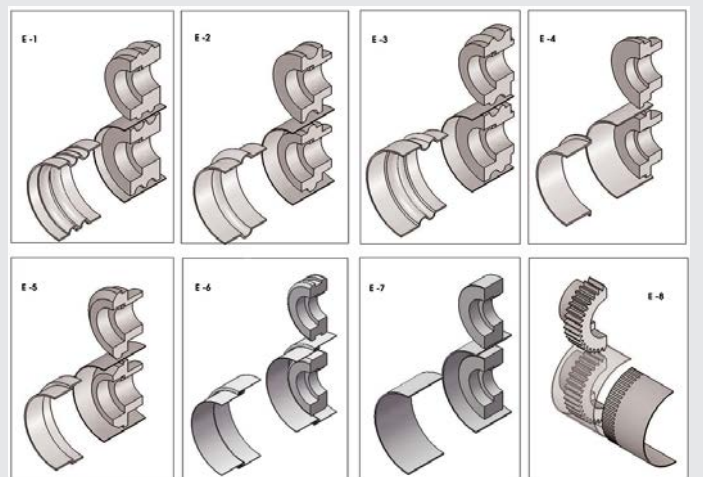

# E-FFM 12-4,0 / E-FFM 12-4,1

## FOLDING MACHINES

**PREMIUM-LINE**

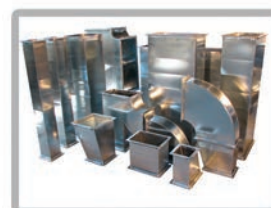
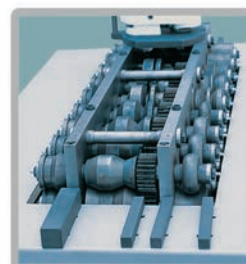

PIC: E-FFM 12-4,0

7 STATION FOLDING MACHINE

Folding Machines

- » drive system: with gear
- » ideal for industry and handcraft
- » high-quality machine

**Please specify fold forms (types 1-4):**



fold forms 1 = E-FFM 12-4,0

fold forms 2 = E-FFM 12-4,1

### 9 STATION FOLDING MACHINE

Description	E-FFM 12-4,0	E-FFM 12-4,1
max. capacity	0,5 / 1,2 mm	0,5 / 1,2 mm
operating speed	6 m/min	6 m/min
motor power	400 V / 50 Hz / 2,2 kW	400 V / 50 Hz / 2,2 kW
dimensions (W x D x H)	800 x 1.300 x 1.100 mm	800 x 1.300 x 1.100 mm
weight	456 kg	456 kg
	<b>E-FFM 12-4,0</b>	<b>E-FFM 12-4,1</b>
<b>EAN</b>	<b>4260364294637</b>	<b>4260364294644</b>
<b>Item No.</b>	<b>354 3140</b>	<b>354 3141</b>

# E-PFM 13

## PNEUMATIC REBATE PRESSING MACHINE

**PREMIUM-LINE**

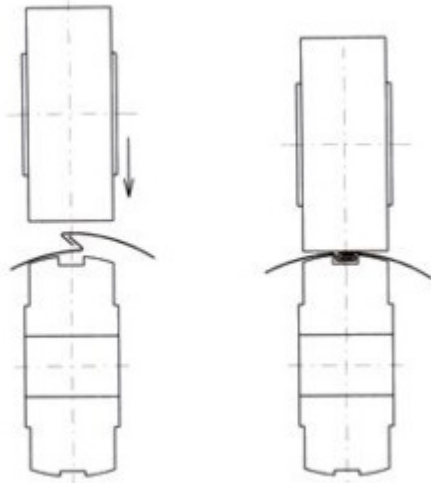

PIC: SKETCH PRESSING POSITION

PIC: E-PFM 13

### E-PFM 13

- » pinion geared clamping system
- » easy handling through pneumatic pressure piston
- » clamping and turning controlled by foot pedal
- » protection of the pneumatic system through air strainer
- » hardened folding rollers
- » slip system with ball bearing
- » construction according to CE safety standards

Description	E-PFM 13
fold length	1.300 mm
min. fold diameter	120 mm
max. fold diameter	1.000 mm
max. sheet thickness	1,2 mm
operating pressure	8 bar
pressure performance	1.000 kg
motor power	400 V / 50 Hz / 0,37 kW
dimensions (L x D x H)	1.720 x 900 x 1.650 mm
weight	300 kg
	<b>E-PFM 13</b>
<b>EAN</b>	<b>4260364294620</b>
<b>Item No.</b>	<b>354 3013</b>

DRILLING

MILLING

TURNING

SAWING

GRINDING

BENDING

CUTTING / PRESSING

OTHER MACHINES

ACCESSORIES



# E-BKS 6 / E-BKS 8 FLANGING MACHINES

**PREMIUM-LINE**



PIC: E-BKS 8

Flanging Machines

## E-BKS 6 / E-BKS 8

- » standard one kit flanging rolls (R25) and one kit blades
- » extreme solid and robust cast-iron construction
- » blade made of special steel K2379, in bronze bearing
- » blades are hardened, adjustable and regrindable
- » gear motor with brake system
- » cutting and flanging with one head
- » excellent price-performance ratio



Description	E-BKS 6	E-BKS 8
sheet thickness	max. 6,0 mm	max. 8,0 mm
min. workpiece	440 mm	720 mm
max. workpiece	4.000 mm	4.500 mm
max. flanging radius	35 mm	100 mm
motor power	400 V / 50 Hz / 8 kW	400 V / 50 Hz / 10 kW
dimensions (L x D x H)	4.250 x 720 x 2.000 mm	4.600 x 1.250 x 2.700 mm
weight	2.050 kg	4.400 kg
	<b>E-BKS 6</b>	<b>E-BKS 8</b>
<b>EAN</b>	<b>4260364294545</b>	<b>4260364294552</b>
<b>Item No.</b>	<b>353 4006</b>	<b>353 4008</b>

## OPTIONAL ACCESSORIES

- » flanging rolls (50, 75 and 100)
- » extra set of cutting blades

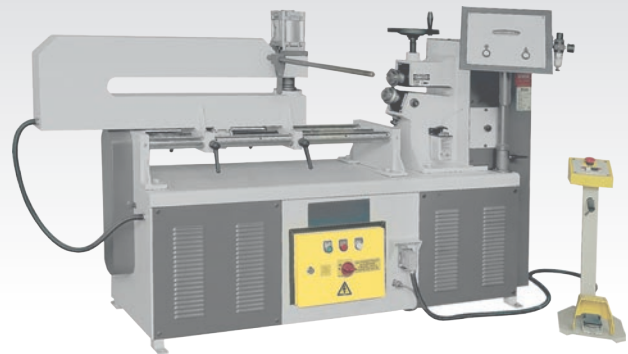
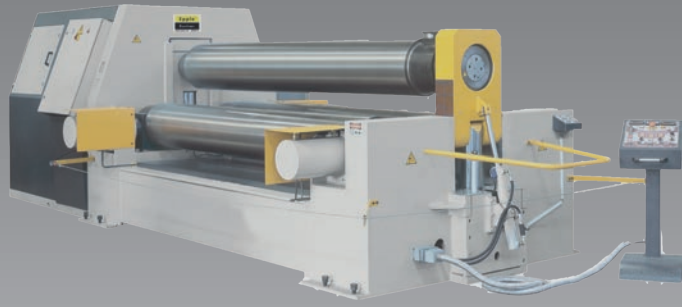

# Bending Machines

# AKB 1.020-2,5 / AKB 1.270-2,0 BENDING MACHINES

THE ORIGINAL  
Epple Maschinen®



YouTube

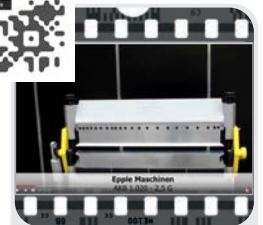

Product video on  
www.epple.com

**Hardened segments on upper and lower cheek as standard.**

**AKB 1.020-2,5 / AKB 1.270-2,0**

WITH SEGMENTS (UPPER AND LOWER  
DETACHABLE SEGMENTS)

- » ideal for industry and handcraft
- » high quality in a modern design
- » foot operated upper beam which gives you free hands for the working material
- » self-lubricated bearings
- » hardened segments that can be removed at the top and bottom as standard
- » heavy support cylinder enables folding of steel sheets up to 2,5 mm
- » opening between the upper - and lower beams can be adjusted to 50 mm
- » bending angle adjustment manual with scale

- » **bending performance data refer to 24 kg/m<sup>2</sup> sheet bending limit**
- » **sheet thickness for stainless steel: factor 0,5**
- » **sheet thickness for aluminum: factor 1,2**

Description	AKB 1.020-2,5	AKB 1.270-2,0
working length	max. 1.020 mm	max. 1.270 mm
sheet thickness (hardness ≤ 48 Rockwell)	max. 2,5 mm	max. 2,0 mm
bending angle	max. 135°	max. 135°
spindle hole	50 mm	50 mm
dimensions (L x D x H)	1.340 x 620 x 1.180 mm	1.610 x 940 x 1.180 mm
weight	320 kg	370 kg
	<b>AKB 1.020-2,5</b>	<b>AKB 1.270-2,0</b>
<b>EAN</b>	<b>4260364291193</b>	<b>4260657650607</b>
<b>Item No.</b>	<b>125 0220</b>	<b>125 0127</b>

# AKB 1.020-2,5 G

## BENDING MACHINE



**Hardened segments on upper and lower cheek as standard.**

### AKB 1.020-2,5 G

WITH SEGMENTS (UPPER AND LOWER DETACHABLE SEGMENTS)

- » ideal for industry and handcraft
- » high quality in a modern design
- » foot operated upper beam which gives you free hands for the working material
- » self-lubricated bearings
- » standard with three segment rows, one above, two below
- » heavy support cylinder enables folding of steel sheets up to 2,5 mm
- » opening between the upper - and lower beams can be adjusted to 50 mm
- » bending angle adjustment manual with scale

- » **bending performance data refer to 24 kg/m<sup>2</sup> sheet bending limit**
- » **sheet thickness for stainless steel: factor 0,5**
- » **sheet thickness for aluminum: factor 1,2**

Description	AKB 1.020-2,5 G
working length	max. 1.020 mm
sheet thickness (hardness ≤ 48 Rockwell)	max. 2,0 mm
bending angle	max. 135°
spindle hole	50 mm
dimensions (L x D x H)	1.346 x 810 x 1.243 mm
weight	430 kg
	<b>AKB 1.020-2,5 G</b>
<b>EAN</b>	<b>4260364291209</b>
<b>Item No.</b>	<b>125 1220</b>



# AKB 2.020-2,0

## BENDING MACHINE



PIC: AKB 2.020-2,0

### AKB 2.020-2,0

WITH SEGMENTS (UPPER AND LOWER  
DETACHABLE SEGMENTS)

- » ideal for industry and handcraft
- » high quality in a modern design
- » foot operated upper beam which gives you free hands for the working material
- » self-lubricated bearings
- » standard with top and bottom removable segments
- » spring-loaded dampers, which makes it easier to bend sheet metal up to 2,0 mm
- » opening between the upper- and lower beams can be adjusted to 50 mm
- » bending angle adjustment manual with scale

### OPTIONAL ACCESSORIES

- » manually adjustable backgauge

- » **bending performance data refer to 24 kg/m<sup>2</sup> sheet bending limit**
- » **sheet thickness for stainless steel: factor 0,5**
- » **sheet thickness for aluminum: factor 1,2**

Description	AKB 2.020-2,0
working length	max. 2.020 mm
sheet thickness (hardness ≤ 150 Rockwell)	max. 2,0 mm
bending angle	max. 135°
spindle hole	50 mm
dimensions (L x D x H)	2.300 x 1.200 x 950 mm
weight	560 kg
	<b>AKB 2.020-2,0</b>
<b>EAN</b>	<b>4260364291216</b>
<b>Item No.</b>	<b>125 0320</b>

**E-AKB-S 1.220-0,8 / E-AKB-S 2.040-0,8**  
**E-AKB-S 2.540-0,8 / E-AKB-S 3.040-0,8**  
**MANUAL BENDING MACHINES WITH ROLLER SHEARS**

**NEW**

**PREMIUM-LINE**



PIC: E-AKB-S 2.540-0,8

**E-AKB-S 1.220-0,8 / E-AKB-S 2.040-0,8 / E-AKB-S 2.540-0,8 / E-AKB-S 3.040-0,8**

Manual bending machine with additional sheet shears for thin sheets up to 0,8 mm (also e.g. copper, aluminum or zinc sheet) in one operation for edges and cutting.

Description	E-AKB-S 1.220-0,8	E-AKB-S 2.040-0,8	E-AKB-S 2.540-0,8	E-AKB-S 3.040-0,8
working length	max. 1.220 mm	max. 2.040 mm	max. 2.540 mm	max. 3.040 mm
sheet thickness (hardness ≤ 48 Rockwell)	max. 0,8 mm	max. 0,8 mm	max. 0,8 mm	max. 0,8 mm
bending angle	max. 110°	max. 110°	max. 110°	max. 110°
dimensions (L x D x H)	1.650 x 320 x 850 mm	2.400 x 750 x 850 mm	3.000 x 750 x 850 mm	3.500 x 750 x 850 mm
weight	180 kg	290 kg	350 kg	440 kg
	<b>E-AKB-S 1.220-0,8</b>	<b>E-AKB-S 2.040-0,8</b>	<b>E-AKB-S 2.540-0,8</b>	<b>E-AKB-S 3.040-0,8</b>
<b>EAN</b>	<b>4260364298307</b>	<b>4260364298314</b>	<b>4260364298321</b>	<b>4260364298338</b>
<b>Item No.</b>	<b>325 0122</b>	<b>325 0204</b>	<b>325 0254</b>	<b>325 0304</b>

DRILLING

MILLING

TURNING

SAWING

GRINDING

BENDING

CUTTING /  
PRESSING

OTHER  
MACHINES

ACCESSORIES

AKB 2.020-1,5 E / AKB 2.020-1,5 ES  
AKB 2.520-1,0 E / AKB 2.520-1,0 ES  
AKB 3.020-1,0 E / AKB 3.020-1,0 ES

BENDING MACHINES WITH MOTORS



PIC: AKB 2.020-1,5 ES

- » bending performance data refer to 24 kg/m<sup>2</sup> sheet bending limit
- » sheet thickness for stainless steel: factor 0,5
- » sheet thickness for aluminum: factor 1,2

For more technical data check page 177.

Description	AKB 2.020-1,5 E	AKB 2.020-1,5 ES	AKB 2.520-1,0 E
working length	max. 2.000 mm	max. 2.000 mm	max. 2.500 mm
sheet thickness (hardness ≤ 50 Rockwell)	max. 1,5 mm	max. 1,5 mm	max. 1,0 mm
bending angle	0° - max. 135°	0° - max. 135°	0° - max. 135°
spindle hole	100 mm	100 mm	100 mm
motor power pressing	0,37 kW	0,37 kW	0,37 kW
motor power edging	0,75 kW	0,75 kW	0,75 kW
motor power	400 V / 50 Hz / 0,75 kW	400 V / 50 Hz / 0,75 kW	400 V / 50 Hz / 0,75 kW
dimensions (L x D x H)	2.830 x 760 x 1.420 mm	2.830 x 760 x 1.420 mm	3.330 x 760 x 1.410 mm
weight	925 kg	965 kg	1.260 kg
	<b>AKB 2.020-1,5 E</b>	<b>AKB 2.020-1,5 ES</b>	<b>AKB 2.520-1,0 E</b>
<b>EAN</b>	<b>4260364291223</b>	<b>4260364291230</b>	<b>4260364291247</b>
<b>Item No.</b>	<b>125 2202</b>	<b>125 3202</b>	<b>125 2252</b>



PIC: OPTIONAL BACK GAUGE (MANUALLY)

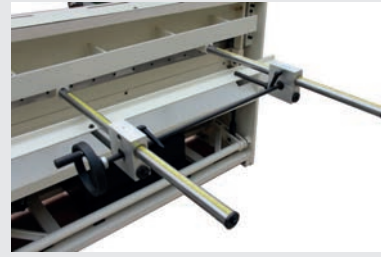

PIC: OPTIONAL BACK GAUGE (VIA HAND WHEEL)

## BENDING MACHINES

- » ideal for industry and handcraft
- » high quality in a modern design
- » operation via selector switch and foot pedal
- » foot operated upper beam which gives you free hands for the working material
- » self-lubricated bearings
- » opening between the upper- and lower beams can be adjusted up to 100 mm
- » bending angle adjustment via scale ring with sensor

E = electrical adjustment of the upper beam and pivoting of the lower beam

ES = additional upper cheek segmented



- » bending performance data refer to 24 kg/m<sup>2</sup> sheet bending limit
- » sheet thickness for stainless steel: factor 0,5
- » sheet thickness for aluminum: factor 1,2

Description	AKB 2.520-1,0 ES	AKB 3.020-1,0 E	AKB 3.020-1,0 ES
working length	max. 2.500 mm	max. 3.000 mm	max. 3.000 mm
sheet thickness (hardness ≤ 50 Rockwell)	max. 1,0 mm	max. 1,0 mm	max. 1,0 mm
bending angle	0° - max. 135°	0° - max. 135°	0° - max. 135°
spindle hole	100 mm	100 mm	100 mm
motor power pressing	0,37 kW	0,37 kW	0,37 kW
motor power edging	0,75 kW	0,75 kW	0,75 kW
dimensions (L x D x H)	3.330 x 760 x 1.410 mm	3.830 x 760 x 1.450 mm	3.830 x 760 x 1.450 mm
weight	1.310 kg	1.560 kg	1.630 kg
	<b>AKB 2.520-1,0 ES</b>	<b>AKB 3.020-1,0 E</b>	<b>AKB 3.020-1,0 ES</b>
<b>EAN</b>	<b>4260364291254</b>	<b>4260364291261</b>	<b>4260364291278</b>
<b>Item No.</b>	<b>125 3252</b>	<b>125 2302</b>	<b>125 3302</b>

DRILLING

MILLING

TURNING

SAWING

GRINDING

BENDING

CUTTING / PRESSING

OTHER MACHINES

ACCESSORIES



# E-AKB-H 1.260-2,0

## BENDING MACHINES WITH HYDRAULIC SUPPORT

NEW

PREMIUM-LINE



### E-AKB-H 1.260-2,0

Stable swivel bending machine based on a manual bending bench but with hydraulic support of the bending beam.

Description	E-AKB-H 1.260-2,0
working length	1.260 mm
sheet thickness (hardness ≤ 50 Rockwell)	2,0 mm
bending angle	max. 135°
motor power pressing	0,9 kW
dimensions (L x D x H)	1.600 x 920 x 1.180 mm
weight	480 kg
	<b>E-AKB-H 1.260-2,0</b>
<b>EAN</b>	<b>4260657650195</b>
<b>Item No.</b>	<b>325 1126</b>

- » segments on the upper beam
- » the workpiece is clamped manually
- » Bending is performed hydraulically by an electric pump using up and down buttons on the control panel, which is connected to the machine by a cable.
- » the control panel has an additional emergency stop button
- » bending angle adjustment manual with scale

# E-AKB 1.020-4,5 HS / E-AKB 1.520-3,5 HS / E-AKB 2.520-2,5 HS

BENDING MACHINES WITH HYDRAULIC BENDING DRIVE

**NEW**

**PREMIUM-LINE**



PIC: E-AKB 1.520-3,5 HS

## E-AKB 1.020-4,5 HS / E-AKB 1.520-3,5 HS / E-AKB 2.520-2,5 HS

Powerful swivel bending machine for the workshop with easy operation.

- » upper beam with removable segments
- » manual adjustment of the bending angle via scale
- » manual control panel on cable, optionally via control panel and foot pedal

## OPTIONAL ACCESSORIES

- » control panel
- » foot pedal
- » digital display
- » backgauge

Description	E-AKB 1.020-4,5 HS	E-AKB 1.520-3,5 HS	E-AKB 2.520-2,5 HS
working length	1.020 mm	1.520 mm	2.520 mm
sheet thickness (hardness ≤ 50 Rockwell)	max. 4,5 mm	max. 3,5 mm	max. 2,5 mm
bending angle	0° - 135°	0° - 135°	0° - 135°
motor power pressing	1,1 kW	2,2 kW	2,2 kW
dimensions (L x D x H)	1.160 x 1.100 x 1.260 mm	1.710 x 1.100 x 1.260 mm	2.730 x 1.100 x 1.260 mm
weight	750 kg	1.350 kg	2.250 kg
	<b>E-AKB 1.020-4,5 HS</b>	<b>E-AKB 1.520-3,5 HS</b>	<b>E-AKB 2.520-2,5 HS</b>
<b>EAN</b>	4260657650119	4260657650126	4260657651802
<b>Item No.</b>	325 1102	325 1152	325 1252

# MAKB 1.250-1,6 / MAKB 2.500-1,6 MAKB 3.200-1,2

## MAGNETIC BENDING MACHINES



PIC: MAKB 1.250-1,6

### MAKB 1.250-1,6 / MAKB 2.500-1,6 / MAKB 3.200-1,2

- » ideal for bending steel, copper, stainless steel, aluminium etc.
- » easy, quick and comfortable handling
- » powerful electromagnetic system for ideal bending results
- » the clamping over the entire width guarantees a precise bending result
- » segmentation in mm: 25 - 40 - 50 - 70 - 140 - 280 - 700 - 1.250
- » exact angle adjustment up to 180°
- » for non-magnetic materials a bending strip is required

#### INCLUDED IN DELIVERY

- » bending angle stop, widening, bending cheek and rear stop
- » sharp bending bar and narrow slotted bending bar (model MAKB 1.250-1,6)
- » 7 bending segments
- » foot pedal



Product video on  
www.epple.com

Description	MAKB 1.250-1,6	MAKB 2.500-1,6	MAKB 3.200-1,2
folding length	1.250 mm	2.500 mm	3.200 mm
fixing pressure	6 t	12 t	10 t
sheet thickness (hardness ≤ 48 Rockwell) without bending bar / with bending bar	1,6 mm / 1,2 mm	1,6 mm / 1,2 mm	1,2 mm / 1,0 mm
min. height distance when bending 180°	16 mm	19 mm	45 mm
motor power	230 V / 50 Hz	230 V / 50 Hz	230 V / 50 Hz
dimensions (L x D x H)	1.450 x 380 x 1.120 mm	2.700 x 380 x 1.120 mm	3.400 x 380 x 1.120 mm
weight	185 kg	290 kg	381 kg
	<b>MAKB 1.250-1,6</b>	<b>MAKB 2.500-1,6</b>	<b>MAKB 3.200-1,2</b>
<b>EAN</b>	<b>4260364294484</b>	<b>4260364296280</b>	<b>4260364296297</b>
<b>Item No.</b>	<b>125 5125</b>	<b>125 5250</b>	<b>125 5320</b>

Note: Please do not use the machine when you have a cardiac pacemaker



# Round Bending-/Roller Bending Machines



## RM 1.020-1,5 / RME 1.020-1,5

### 3-ROLLER-ROUND BENDING MACHINES



PIC: RM 1.020-1,5



PIC: RME 1.020-1,5

#### RM 1.020-1,5 / RME 1.020-1,5 WITH CONE BENDING DEVICE

- » heavy duty cast iron construction
- » rolls are made of wear-resistant steel
- » asymmetrical 3-roller system with swing-out top roller and eccentric lock
- » upper roll with indicatory slot
- » lower roll adjustment with adjusting lever and eccentric
- » back roll through hand wheel
- » lower and back rolls are supplied with various grooves for rolling of wire inserts or smaller work pieces
- » transmission gear

» bending performance data refer to 24 kg/m<sup>2</sup> sheet bending limit  
 » sheet thickness for stainless steel: factor 0,5  
 » sheet thickness for aluminum: factor 1,2

Description	RM 1.020-1,5
roller length	1.020 mm
sheet thickness (hardness ≤ 150 HB)	1,5 mm
roller diameter	60 mm
min. bending radius	35 mm
dimensions (L x D x H)	1.700 x 540 x 1.110 mm
weight	250 kg
<b>RM 1.020-1,5</b>	
<b>EAN</b>	<b>4260364291285</b>
<b>Item No.</b>	<b>125 0520</b>

#### RME 1.020-1,5 WITH ELECTRIC MOTOR AND CONE BENDING DEVICE

- » heavy duty cast iron construction
- » rolls are made of wear-resistant steel
- » asymmetrical 3-roller system with swing-out top roller and eccentric lock
- » upper roll with indicatory slot
- » lower roll adjustment with adjusting lever and eccentric
- » back roll through hand wheel
- » lower and rear roller with wire insertion groove
- » transmission gear
- » foot operating enables you free hands for the working material
- » electric motor 400 V / 750 W with reduction gear
- » foot pedal for forward and reverse
- » safety barrier with emergency stop switch

**When ordering please name the type of material which will be used**

Description	RME 1.020-1,5
roller length	1.020 mm
sheet thickness (hardness ≤ 150 HB)	1,5 mm
roller diameter	60 mm
min. bending radius	35 mm
motor power	400 V / 50 Hz / 0,75 kW
dimensions (L x D x H)	1.700 x 600 x 1.100 mm
weight	260 kg
<b>RME 1.020-1,5</b>	
<b>EAN</b>	<b>4260364291377</b>
<b>Item No.</b>	<b>125 1520</b>

# RME 1.300-1,5

## 3-ROLLER-ROUND BENDING MACHINE

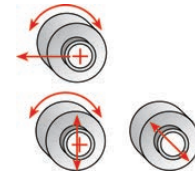

### RME 1.300-1,5 WITH ELECTRIC MOTOR AND CONE BENDING DEVICE

- » heavy duty cast iron construction
- » rolls are made of wear-resistant steel
- » asymmetrical 3-roller quality bending roller
- » upper roll with indicatory slot
- » lower roll adjustment with adjusting lever and eccentric
- » back roll through hand wheel
- » lower and back rolls are supplied with various grooves for rolling of wire inserts or smaller work pieces
- » transmission gear
- » foot operation enables you free hands for the working material
- » electric motor 400 V / 750 W with reduction gear
- » foot pedal for forward and reverse
- » safety barrier with emergency stop switch

- » bending performance data refer to 24 kg/m<sup>2</sup> sheet bending limit
- » sheet thickness for stainless steel: factor 0,5
- » sheet thickness for aluminum: factor 1,2

Description	RME 1.300-1,5
roller length	1.300 mm
sheet thickness (hardness ≤ 150 HB)	1,5 mm
roller diameter	75 mm
min. bending radius	57,5 mm
motor power	400 V / 50 Hz / 0,75 kW
dimensions (L x D x H)	1.700 x 400 x 1.100 mm
weight	300 kg
	<b>RME 1.300-1,5</b>
<b>EAN</b>	<b>4260364291384</b>
<b>Item No.</b>	<b>125 1315</b>

E-RB 1.050-2,0 / E-RB 1.270-1,5  
E-RB 1.550-1,2 / E-RB 2.050-1,0

**PREMIUM-LINE**

## 3-ROLLER-ROUND BENDING MACHINES



PIC: E-RB 1.270-1,5

E-RB 1.050-2,0 / E-RB 1.270-1,5  
E-RB 1.550-1,2 / E-RB 2.050-1,0

- » heavy duty cast iron construction
- » are made of SAE-1050 quality steel
- » asymmetrical 3-roller system with swing-out top roller and eccentric lock
- » usable from the right and left
- » upper roll with straightening groove
- » bottom roller adjustment with adjusting lever and eccentric
- » rear roller adjustment via hand lever
- » bottom and rear roll with wire inlay

**When ordering please name the type of material which will be used**

- » **bending performance data refer to 24 kg/m<sup>2</sup> sheet bending limit**
- » **sheet thickness for stainless steel: factor 0,5**
- » **sheet thickness for aluminum: factor 1,2**

Description	E-RB 1.050-2,0	E-RB 1.270-1,5	E-RB 1.550-1,2	E-RB 2.050-1,0
roller length	1.050 mm	1.270 mm	1.550 mm	2.050 mm
sheet thickness (St 37)	max 2,0 mm	max 1,5 mm	max 1,2 mm	max 1,0 mm
roller diameter	75 mm	75 mm	75 mm	75 mm
min. bending diameter	110 mm	110 mm	110 mm	110 mm
dimensions (L x D x H)	1.930 x 700 x 1.160 mm	2.150 x 700 x 1.160 mm	2.430 x 700 x 1.160 mm	2.930 x 700 x 1.160 mm
weight	300 kg	330 kg	365 kg	525 kg

	E-RB 1.050-2,0	E-RB 1.270-1,5	E-RB 1.550-1,2	E-RB 2.050-1,0
<b>EAN</b>	4260364291292	4260364291308	4260364291315	4260364291322
<b>Item No.</b>	352 0050	352 0127	352 0155	352 0205

	E-RB 1.050-2,0 GW	E-RB 1.270-1,5 GW	E-RB 1.550-1,2 GW	E-RB 2.050-1,0 GW
<b>EAN</b>	4260364291339	4260364291346	4260364291353	4260364291360
<b>Item No.</b>	352 0055	352 1127	352 1155	352 1205

GW = hardened rolls

# E-RME 1.050-2,0 / E-RME 1.270-1,5 E-RME 1.550-1,2 / E-RME 2.050-1,0

## 3-ROLLER-ROUND BENDING MACHINES



PIC: E-RME 1.550-1,2

**PREMIUM-LINE**

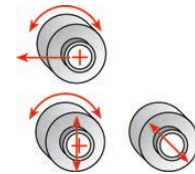

When ordering please name the type of material which will be used

- » bending performance data refer to 24 kg/m<sup>2</sup> sheet bending limit
- » sheet thickness for stainless steel: factor 0,5
- » sheet thickness for aluminum: factor 1,2

### E-RME 1.050-2,0 / E-RME 1.270-1,5 E-RME 1.550-1,2 / E-RME 2.050-1,0

- » heavy duty cast iron construction
- » are made of SAE-1050 quality steel
- » asymmetrical 3-roller system with swing-out top roller and eccentric lock
- » upper roll with indicatory slot
- » bottom roller adjustment with adjusting lever and eccentric
- » rear roller adjustment via hand lever
- » lower and rear roller with wire insertion groove

Description	E-RME 1.050-2,0	E-RME 1.270-1,5	E-RME 1.550-1,2	E-RME 2.050-1,0
roller length	max. 1.050 mm	max. 1.270 mm	max. 1.550 mm	max. 2.050 mm
sheet thickness (St 37)	max. 2,0 mm	max. 1,5 mm	max. 1,2 mm	max. 1,0 mm
roller diameter	75 mm	75 mm	75 mm	75 mm
min. bending diameter	110 mm	110 mm	110 mm	110 mm
motor power	400 V / 50 Hz / 1,5 kW	400 V / 50 Hz / 1,5 kW	400 V / 50 Hz / 1,5 kW	400 V / 50 Hz / 1,5 kW
dimensions (L x D x H)	1.610 x 700 x 1.160 mm	1.830 x 700 x 1.160 mm	2.110 x 700 x 1.160 mm	2.610 x 700 x 1.160 mm
weight	385 kg	400 kg	430 kg	590 kg
	<b>E-RME 1.050-2,0</b>	<b>E-RME 1.270-1,5</b>	<b>E-RME 1.550-1,2</b>	<b>E-RME 2.050-1,0</b>
<b>EAN</b>	4260364291391	4260364291407	4260364291414	4260364291421
<b>Item No.</b>	352 2050	352 2127	352 2155	352 2205

	E-RME 1.050-2,0 GW	E-RME 1.270-1,5 GW	E-RME 1.550-1,2 GW	E-RME 2.050-1,0 GW
<b>EAN</b>	4260364291438	4260364291445	4260364291452	4260364291469
<b>Item No.</b>	352 2055	352 3127	352 3155	352 3205

## E-RBE 1.050-3,0 / E-RBE 1.270-2,5 E-RBE 1.550-2,0 / E-RBE 2.050-1,5

### 3-ROLLER-ROUND BENDING MACHINES

**PREMIUM-LINE**



PIC: E-RBE 1.050-3,0

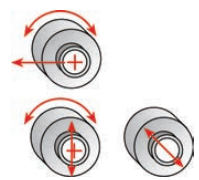

#### OPTIONAL EQUIPMENT

- » motorized roller adjustment
  - » digital display
  - » hardened rollers
- » bending performance data refer to 24 kg/m<sup>2</sup> sheet bending limit
  - » sheet thickness for stainless steel: factor 0,5
  - » sheet thickness for aluminum: factor 1,2

**E-RBE 1.050-3,0 / E-RBE 1.270-2,5**  
**E-RBE 1.550-2,0 / E-RBE 2.050-1,5**

- » heavy duty cast iron construction
- » are made of SAE-1050 quality steel
- » asymmetrical 3-roller system with swing-out top roller and eccentric lock
- » upper roll with indicatory slot and safety switch
- » lower roll adjustment with adjusting lever and eccentric
- » rear roller adjustment via hand wheel
- » lower and rear roller with wire insertion groove
- » with conical bending device (sheet thickness less)
- » the foot control leaves both hands free for Free material guidance
- » electric motor 400 V / 1,1 kW / 1,5 kW
- » foot pedal for forward and reverse
- » safety device with emergency stop switch

**When ordering please name the type of material which will be used**

Description	E-RBE 1.050-3,0	E-RBE 1.270-2,5	E-RBE 1.550-2,0	E-RBE 2.050-1,5
roller length	max. 1.050 mm	max. 1.270 mm	max. 1.550 mm	max. 2.050 mm
sheet thickness (St 37)	max. 3,0 mm	max. 2,5 mm	max. 2,0 mm	max. 1,5 mm
roller diameter	90 mm	90 mm	90 mm	95 mm
min. bending diameter	200 mm	200 mm	200 mm	200 mm
motor power	400 V / 50 Hz / 1,1 kW	400 V / 50 Hz / 1,1 kW	400 V / 50 Hz / 1,5 kW	400 V / 50 Hz / 1,5 kW
dimensions (L x D x H)	1.630 x 700 x 1.200 mm	1.850 x 700 x 1.200 mm	2.130 x 700 x 1.200 mm	2.630 x 700 x 1.200 mm
weight	455 kg	490 kg	545 kg	665 kg
	<b>E-RBE 1.050-3,0</b>	<b>E-RBE 1.270-2,5</b>	<b>E-RBE 1.550-2,0</b>	<b>E-RBE 2.050-1,5</b>
<b>EAN</b>	4260364291476	4260364291483	4260364291513	4260364291520
<b>Item No.</b>	352 1050	352 1270	352 1550	352 3050

	E-RBE 1.050-3,0 GW	E-RBE 1.270-2,5 GW	E-RBE 1.550-2,0 GW	E-RBE 2.050-1,5 GW
<b>EAN</b>	4260364291490	4260364291506	4260364291537	4260364291544
<b>Item No.</b>	352 1055	352 1275	352 1555	352 3055

GW = hardened rolls



# E-RBE-H 1.270-2,5 / E-RBE-H 1.550-2,0 E-RBE-H 2.050-1,5

## 3-ROLLER-ROUND BENDING MACHINES

**PREMIUM-LINE**



PIC: E-RBE-H 1.270-2,5

- » bending performance data refer to 24 kg/m<sup>2</sup> sheet bending limit
- » sheet thickness for stainless steel: factor 0,5
- » sheet thickness for aluminum: factor 1,2

**E-RBE-H 1.270-2,5 / E-RBE-H 1.550-2,0  
E-RBE-H 2.050-1,5**

- » 3-roller system (asymmetrical) with swing-out top roller
- » upper and lower rolls easy adjustable
- » rolls are made of high pressure steel
- » lower roller adjustment due to control lever and excentre
- » roller adjustment due to handwheel
- » lower and rear roller with wire insertion groove
- » foot operation leaves both hands free for material guidance
- » safety device with emergency stop switch

### OPTIONAL EQUIPMENT

- » hardened rollers
- » digital readout for rear rollers
- » stepless roller speeds

Description	E-RBE-H 1.270-2,5	E-RBE-H 1.550-2,0	E-RBE-H 2.050-1,5
roller length	1.270 mm	1.550 mm	2.050 mm
sheet thickness	2,5 mm	2,0 mm	1,5 mm
roller diameter	90 mm	90 mm	95 mm
roller speed	6 m/min	6 m/min	6 m/min
motor power	400 V / 50 Hz / 1,1 kW	400 V / 50 Hz / 1,5 kW	400 V / 50 Hz / 1,5 kW
wire chunks diameter	4 / 7 / 10 mm	4 / 7 / 10 mm	4 / 7 / 10 mm
dimensions (L x D x H)	1.850 x 700 x 1.200 mm	2.130 x 700 x 1.200 mm	2.630 x 700 x 1.200 mm
weight	520 kg	580 kg	715 kg
	<b>E-RBE-H 1.270-2,5</b>	<b>E-RBE-H 1.550-2,0</b>	<b>E-RBE-H 2.050-1,5</b>
<b>EAN</b>	<b>4260364296303</b>	<b>4260364296310</b>	<b>4260364296327</b>
<b>Item No.</b>	<b>352 1225</b>	<b>352 1520</b>	<b>352 2015</b>

## E-RWE 1.270-3,0 / E-RWE 1.550-2,5 E-RWE 2.050-1,8 / E-RWE 2.550-1,0

### 3-ROLLER-ROUND BENDING MACHINES

**NEW**

**PREMIUM-LINE**



PIC: E-RWE 1.270-2,5

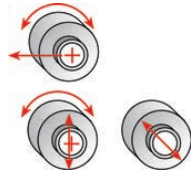

**OPTIONAL EQUIPMENT**

- » hardened rollers
- » bending performance data refer to 24 kg/m<sup>2</sup> sheet bending limit
- » sheet thickness for stainless steel: factor 0,5
- » sheet thickness for aluminum: factor 1,2

**E-RWE 1.270-3,0 / E-RWE 1.550-2,5  
E-RWE 2.050-1,8 / E-RWE 2.550-1,0**

- » heavy and stable cast iron construction
- » top and bottom rollers with gear drive
- » rolls are made of SAE-1050 quality steel
- » asymmetrical 3-roller system with swing-out top roller and eccentric shutter
- » rear roller adjustment via handwheel
- » rollers with wire insertion groove
- » with conical bending device (sheet thickness less)
- » the foot control allows both hands to remain free for material handling
- » electric motor 400 V / 1,1 kW / 1,5 kW
- » foot pedal for forward and reverse motion
- » safety device with emergency stop switch

**When ordering please name the type of material which will be used**

Description	E-RWE 1.270-3,0	E-RWE 1.550-2,5	E-RWE 2.050-1,8	E-RWE 2.550-1,0
roller length	max. 1.270 mm	max. 1.550 mm	max. 2.050 mm	max. 2.550 mm
sheet thickness (St 37)	max. 3,0 mm	max. 2,5 mm	max. 1,8 mm	max. 1,0 mm
roller diameter	100 mm	100 mm	100 mm	100 mm
motor power	400 V / 50 Hz / 1,1 kW	400 V / 50 Hz / 1,5 kW	400 V / 50 Hz / 1,5 kW	400 V / 50 Hz / 1,5 kW
roller speed	6 m/min	6 m/min	6 m/min	6 m/min
dimensions (L x D x H)	1.570 x 430 x 1.130 mm	1.770 x 430 x 1.130 mm	2.070 x 430 x 1.130 mm	3.180 x 700 x 1.200 mm
weight	650 kg	700 kg	850 kg	950 kg
	<b>E-RWE 1.050-3,0</b>	<b>E-RWE 1.270-2,5</b>	<b>E-RWE 1.550-2,0</b>	<b>E-RWE 2.050-1,5</b>
<b>EAN</b>	4260364298352	4260364298369	4260364298376	4260364298345
<b>Item No.</b>	352 1230	352 1525	352 2018	351 2510

	E-RWE 1.270-3,0 GW	E-RWE 1.550-2,5 GW	E-RWE 2.050-1,8 GW	E-RWE 2.550-1,0 GW
<b>EAN</b>	4260364298390	4260364298406	4260364298413	4260364298406
<b>Item No.</b>	352 3230	352 3525	352 3018	352 3510

GW = hardened rolls

# E-RBM 1.270-4,0 / E-RBM 1.550-4,0 E-RBM 2.050-3,0

## MOTORIC 3-ROLLER-ROUND BENDING MACHINES

**PREMIUM-LINE**

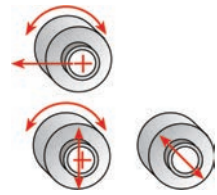

PIC: E-RBM 1.270-4,0

### E-RBM 1.270-4,0 / E-RBM 1.550-4,0 E-RBM 2.050-3,0

- » heavy duty cast iron construction
- » 3-roller system (asymmetrical) with swing-out top roller
- » upper and lower rolls easy adjustable
- » rolls are made of St.1050 high pressure steel
- » with conical bending device (sheet thickness less)
- » wire insertion groove on bottom and rear roller
- » foot operation enables you free hands for the working material
- » powerful 400 V motor



### OPTIONAL ACCESSORIES

- » motorized roller adjustment
- » digital display
- » hardened rollers (GW)

**When ordering please name the type of material which will be used**

- » bending performance data refer to 24 kg/m<sup>2</sup> sheet bending limit
- » sheet thickness for stainless steel: factor 0,5
- » sheet thickness for aluminum: factor 1,2

Description	E-RBM 1.270-4,0	E-RBM 1.550-4,0	E-RBM 2.050-3,0
roller length	max. 1.270 mm	max. 1.550 mm	max. 2.050 mm
sheet thickness (St 37)	max. 4,0 mm	max. 4,0 mm	max. 3,0 mm
roller diameter	120 mm	140 mm	130 mm
min. bending diameter	180 mm	210 mm	195 mm
motor power	400 V / 50 Hz / 2,2 kW	400 V / 50 Hz / 2,2 kW	400 V / 50 Hz / 2,2 kW
roller speed	3,5 m/min	3,5 m/min	3,5 m/min
dimensions (L x D x H)	2.470 x 750 x 1.000 mm	2.700 x 750 x 1.000 mm	3.200 x 750 x 1.000 mm
weight	1.350 kg	1.420 kg	1.500 kg

	E-RBM 1.270-4,0	E-RBM 1.550-4,0	E-RBM 2.050-3,0
<b>EAN</b>	4260364291551	4260364291568	4260364291575
<b>Item No.</b>	352 1274	352 1554	352 2053

	E-RBM 1.270-4,0 GW	E-RBM 1.550-4,0 GW	E-RBM 2.050-3,0 GW
<b>EAN</b>	4260364291582	4260364291599	4260364291605
<b>Item No.</b>	352 2274	352 2554	352 3054

GW = hardened rolls

# E-RBM-S PRO - MODELS

## MOTORIC 3-ROLLER-ROUND BENDING MACHINES

**PREMIUM-LINE**

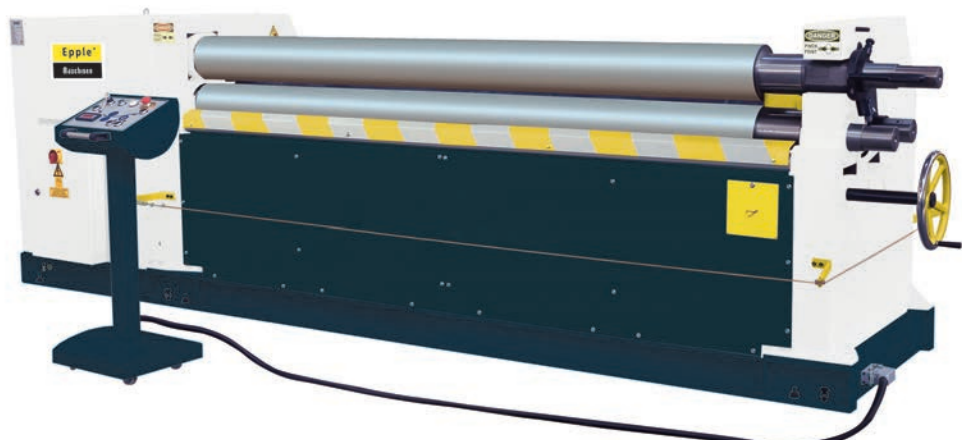

PIC: E-RBM-S 1.550-6,0 PRO

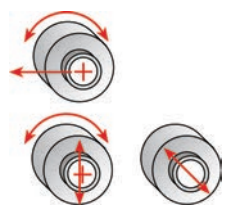

### E-RBM-S PRO - MODELS

- » solid steel construction for highest loads in continuous operation
- » conical bending device as standard (sheet thickness less)
- » motor driven central roller
- » motoric pre-bending by worm gear
- » rolls are made of SAE-1050 quality steel
- » speed reduction gear in oil bath
- » brake motor
- » central lubrication
- » separate, mobile control panel

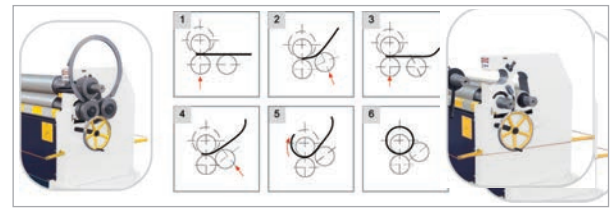

» **bending performance data refer to 24 kg/m<sup>2</sup> sheet bending limit**  
 » **sheet thickness for stainless steel: factor 0,5**  
 » **sheet thickness for aluminum: factor 1,2**

### OPTIONAL ACCESSORIES

- » profile bending rolls
- » digital display
- » hardened rollers
- » extended roller ends for placing profile-bending rolls



**When ordering please name the type of material which will be used**

Description	E-RBM-S PRO 1.550-6,0	E-RBM-S PRO 1.550-9,0	E-RBM-S PRO 2.050-6,0	E-RBM-S PRO 2.550-6,0	E-RBM-S PRO 3.050-6,0
roller length	1.550 mm	1.550 mm	2.050 mm	2.550 mm	3.050 mm
sheet thickness (St 37)	max. 6,0 mm	max. 9,0 mm	max. 6,0 mm	max. 6,0 mm	max. 6,0 mm
roller diameter	130 mm	190 mm	170 mm	190 mm	220 mm
min. bending diameter	195 mm	285 mm	255 mm	285 mm	330 mm
motor power	400 V / 50 Hz / 2,2 kW	400 V / 50 Hz / 4 kW	400 V / 50 Hz / 4 kW	400 V / 50 Hz / 2,2 kW	400 V / 50 Hz / 5,5 kW
dimensions (L x D x H)	3.250 x 650 x 1.020 mm	3.700 x 950 x 1.300 mm	3.850 x 720 x 1.050 mm	4.700 x 950 x 1.300 mm	5.200 x 1.150 x 1.400 mm
weight	1.400 kg	2.750 kg	2.100 kg	3.400 kg	6.000 kg
	<b>E-RBM-S PRO 1.550-6,0</b>	<b>E-RBM-S PRO 1.550-9,0</b>	<b>E-RBM-S PRO 2.050-6,0</b>	<b>E-RBM-S PRO 2.550-6,0</b>	<b>E-RBM-S PRO 3.050-6,0</b>
<b>EAN</b>	4260364291612	4260364291629	4260364291636	4260364291643	4260364291650
<b>Item No.</b>	353 1556	353 1559	353 2056	353 2556	353 3056

	E-RBM-S PRO 1.550-6,0 GW	E-RBM-S PRO 1.550-9,0 GW	E-RBM-S PRO 2.050-6,0 GW	E-RBM-S PRO 2.550-6,0 GW	E-RBM-S PRO 3.050-6,0 GW
<b>EAN</b>	4260364291667	4260364291674	4260364291681	4260364291698	4260364291704
<b>Item No.</b>	353 1557	353 1550	353 2057	353 2557	353 3057

GW = hardened rollers



# E-3RBM PRO UHS - MODELS

## HYDRAULIC 3-ROLLER-ROUND BENDING MACHINES

**NEW**



**PREMIUM-LINE**

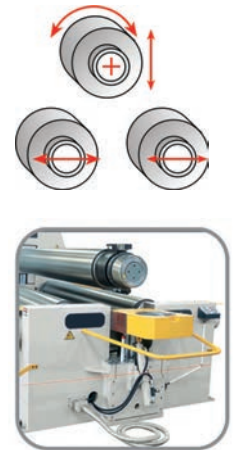

PIC: E-3RBM PRO UHS 3.100-45,0

Particularly stable machines with optimized roll arrangement for bending thick sheets. The standard machines are equipped with hardened rollers.

Top roller with two speeds, safety brake system, electronic balancing system, conical bending device.

The two bottom rollers move horizontally. The distance between the bottom rollers can be reduced for pre-bending tubes with small diameters and small thickness.

Due to the special arrangement of the bottom rolls, plates can be straightened with this machine. The top roll can also be used as a forming roll like a conventional press brake to allow perfect rewinding and calibration of the produced tubes. Funnel moulds with large sheet thickness can also be produced with these machines.

Description	E-3RBM PRO UHS 3.100-55,0	E-3RBM PRO UHS 3.100-60,0	E-3RBM PRO UHS 3.100-65,0
roller length	3.100 mm	3.100 mm	3.100 mm
sheet thickness (St 37)	40,0 mm	45,0 mm	50,0 mm
diameter of the upper rolls	450 mm	580 mm	550 mm
diameter of the lower rolls	420 mm	500 mm	500 mm
motor power	400 V / 50 Hz / 52 kW	400 V / 50 Hz / 73,5 kW	400 V / 50 Hz / 73,5 kW
roller speed	1,5 - 5 m/min	1,5 - 4 m/min	1,5 - 4 m/min
dimensions (L x D x H)	6.650 x 2.800 x 2.200 mm	7.450 x 3.100 x 2.650 mm	7.600 x 3.350 x 2.700 mm
weight	25.000 kg	33.000 kg	45.000 kg
	<b>E-3RBM PRO UHS 3.100-55,0</b>	<b>E-3RBM PRO UHS 3.100-60,0</b>	<b>E-3RBM PRO UHS 3.100-65,0</b>
<b>EAN</b>	<b>4260364299151</b>	<b>4260364299168</b>	<b>4260364299175</b>
<b>Item No.</b>	<b>355 3155</b>	<b>355 3106</b>	<b>355 3165</b>

Description	E-3RBM PRO UHS 3.100-80,0	E-3RBM PRO UHS 3.100-90,0
roller length	3.100 mm	3.100 mm
sheet thickness (St 37)	65,0 mm	75,0 mm
diameter of the upper rolls	620 mm	680 mm
diameter of the lower rolls	560 mm	600 mm
motor power	400 V / 50 Hz / 169 kW	400 V / 50 Hz / 180 kW
roller speed	1,5 - 4 m/min	1,5 - 4 m/min
dimensions (L x D x H)	9.000 x 4.400 x 3.000 mm	9.200 x 4.500 x 3.000 mm
weight	65.000 kg	73.000 kg
	<b>E-3RBM PRO UHS 3.100-80,0</b>	<b>E-3RBM PRO UHS 3.100-90,0</b>
<b>EAN</b>	<b>4260364299182</b>	<b>4260364299199</b>
<b>Item No.</b>	<b>355 3181</b>	<b>355 3190</b>

» bending performance data refer to 24 kg/m<sup>2</sup> sheet bending limit  
 » sheet thickness for stainless steel: factor 0,5  
 » sheet thickness for aluminum: factor 1,2

When ordering please name the type of material which will be used

DRILLING

MILLING

TURNING

SAWING

GRINDING

BENDING

CUTTING / PRESSING

OTHER MACHINES

ACCESSORIES



# E-RBM-H PRO - MODELS

## HYDRAULIC 3-ROLLER-ROUND BENDING MACHINES



PIC: E-RBM-H PRO 1.270-5,0

For technical data check page 193.

### E-RBM-H PRO - MODELS

- » hydraulic 3-roller round bending machine with asymmetrical roll arrangement, ideal for pre-bending
- » 2-axis digital readout system for rear and bottom roller
- » conical bending device, motor-driven adjustment of bottom roller
- » hydraulic folding bearing
- » motorized drive of top and bottom roller
- » inclined position of the bottom roller motorized (conical bending)
- » hydraulic rear roller feed
- » hardened rollers



**drop end**  
» hydraulic drop end for quick removal of machined tube



**Digital Readout**  
» mobile control panel for the control of all elements including 2-axis digital display for back and lower roll

### OPTIONAL

- » 3 driven rollers

» bending performance data refer to 24 kg/m<sup>2</sup> sheet bending limit  
 » sheet thickness for stainless steel: factor 0,5  
 » sheet thickness for aluminum: factor 1,2

### Functional scheme of the bending process

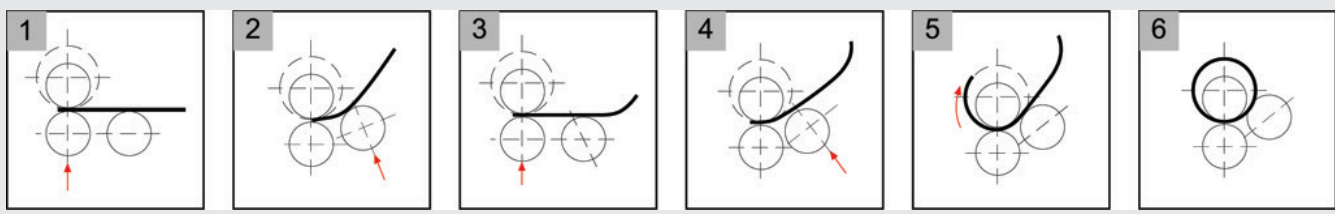

## E-RBM-H PRO - MODELS

### TECHNICAL DATA

When ordering please  
name the type of material  
which will be used

Description	E-RBM-H PRO 1.270-5,0	E-RBM-H PRO 1.270-12,0	E-RBM-H PRO 1.550-6,5
roller length	max. 1.270 mm	max. 1.270 mm	max. 1.550 mm
sheet thickness (St 37)	max. 5,0 mm	max. 12,0 mm	max. 6,5 mm
diameter of the upper and lower rolls	130 mm	200 mm	150 mm
min. bending diameter	195 mm	300 mm	225 mm
motor power	400 V / 50 Hz / 3,3 kW	400 V / 50 Hz / 5,5 kW	400 V / 50 Hz / 3,3 kW
roller speed	5 m/min	6 m/min	6 m/min
dimensions (L x D x H)	3.020 x 950 x 1.100 mm	3.070 x 1.150 x 1.290 mm	3.300 x 950 x 1.110 mm
weight	1.750 kg	2.200 kg	2.000 kg
	E-RBM-H PRO 1.270-5,0	E-RBM-H PRO 1.270-12,0	E-RBM-H PRO 1.550-6,5
<b>EAN</b>	<b>4260364291711</b>	<b>4260364291728</b>	<b>4260364291735</b>
<b>Item No.</b>	<b>354 1250</b>	<b>354 1212</b>	<b>354 1565</b>

Description	E-RBM-H PRO 1.550-12,0	E-RBM-H PRO 2.050-8,0	E-RBM-H PRO 2.050-12,0
roller length	max. 1.550 mm	max. 2.050 mm	max. 2.050 mm
sheet thickness (St 37)	max. 12,0 mm	max. 8,0 mm	max. 12,0 mm
diameter of the upper and lower rolls	220 mm	180 mm	250 mm
min. bending diameter	330 mm	270 mm	375 mm
motor power	400 V / 50 Hz / 7 kW	400 V / 50 Hz / 5,1 kW	400 V / 50 Hz / 3 kW
roller speed	5 m/min	5 m/min	5 m/min
dimensions (L x D x H)	3.500 x 1.200 x 1.370 mm	3.850 x 1.100 x 1.290 mm	4.000 x 1.200 x 1.370 mm
weight	3.250 kg	2.690 kg	4.200 kg
	E-RBM-H PRO 1.550-12,0	E-RBM-H PRO 2.050-8,0	E-RBM-H PRO 2.050-12,0
<b>EAN</b>	<b>4260364291742</b>	<b>4260364291759</b>	<b>4260364291766</b>
<b>Item No.</b>	<b>354 1512</b>	<b>354 2080</b>	<b>354 2012</b>

Description	E-RBM-H PRO 2.550-6,0	E-RBM-H PRO 2.550-10,0	E-RBM-H PRO 3.050-9,0
roller length	max. 2.550 mm	max. 2.550 mm	max. 3.050 mm
sheet thickness (St 37)	max. 6,0 mm	max. 10,0 mm	max. 9,0 mm
diameter of the upper and lower rolls	180 mm	250 mm	250 mm
min. bending diameter	270 mm	375 mm	375 mm
motor power	400 V / 50 Hz / 7,5 kW	400 V / 50 Hz / 7,5 kW	400 V / 50 Hz / 7,5 kW
roller speed	5 m/min	5 m/min	5 m/min
dimensions (L x D x H)	4.350 x 1.100 x 1.290 mm	4.500 x 1.200 x 1.370 mm	5.000 x 1.200 x 1.370 mm
weight	3.070 kg	4.800 kg	5.400 kg
	E-RBM-H PRO 2.550-6,0	E-RBM-H PRO 2.550-10,0	E-RBM-H PRO 3.050-9,0
<b>EAN</b>	<b>4260364291773</b>	<b>4260364291780</b>	<b>4260364291797</b>
<b>Item No.</b>	<b>354 2560</b>	<b>354 2510</b>	<b>354 3090</b>

DRILLING

MILLING

TURNING

SAWING

GRINDING

BENDING

CUTTING /  
PRESSING

OTHER  
MACHINES

ACCESSORIES

# E-3RBM PRO HS - MODELS

## HYDRAULIC 3-ROLLER-ROUND BENDING MACHINES

**PREMIUM-LINE**

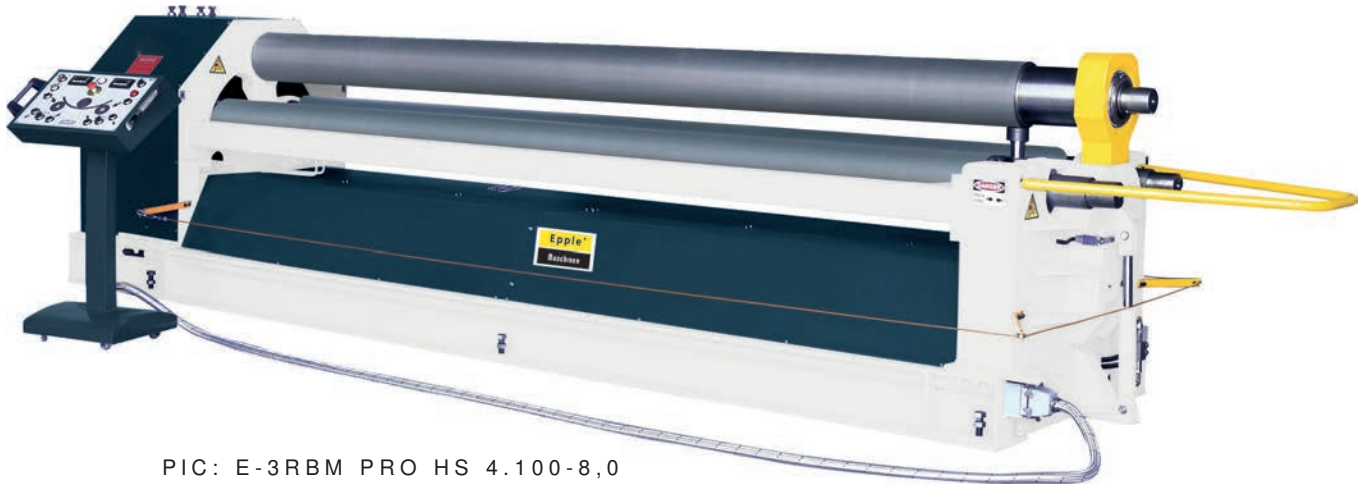
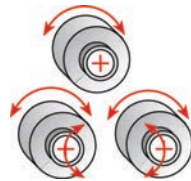

PIC: E-3RBM PRO HS 4.100-8,0

For technical data check page 195.

### E-3RBM PRO HS - MODELS

- » all 3 rolls are driven
- » diagonal positioning of the lower rolls straight from the control panel for conic bending
- » hydraulic drop end for easy work piece removal
- » hydraulic balance system
- » hardened rolls made of forged SAE-1050 quality steel
- » digital display for the roller adjustment



**profile bending**  
» with extended roller ends (optional)



**bending possibility of cones**  
» setting for cone bending (standard)



**prebending**  
» easy prebending of the sheets



**drop end**  
» hydraulic drop end for rapid removal of the machined tubes (standard)

## E-3RBM PRO HS - MODELS

### OPTIONAL ACCESSORIES

- » profile bending rolls
- » hydraulic, stepless control of the roller speed
- » hydraulic support for large radius
- » hydraulic side support
- » hydraulic tube ejection
- » ground and polished rolls

- » **bending performance data refer to 24 kg/m<sup>2</sup> sheet bending limit**
- » **sheet thickness for stainless steel: factor 0,5**
- » **sheet thickness for aluminum: factor 1,2**

**When ordering please name the type of material which will be used**

### TECHNICAL DATA

Description	E-3RBM PRO HS 2.050-13,0	E-3RBM PRO HS 2.550-8,0	E-3RBM PRO HS 2.550-13,0
roller length	max. 2.050 mm	max. 2.550 mm	max. 2.550 mm
sheet thickness (St 37)	max. 13,0 mm	max. 8,0 mm	max. 13,0 mm
diameter of the upper rolls	240 mm	210 mm	280 mm
diameter of the lower rolls	220 mm	190 mm	260 mm
motor power	400 V / 50 Hz / 7,5 kW	400 V / 50 Hz / 7,5 kW	400 V / 50 Hz / 11 kW
roller speed	5 m/min	5 m/min	5 m/min
dimensions (L x D x H)	3.400 x 1.300 x 1.450 mm	3.900 x 1.200 x 1.300 mm	4.600 x 1.400 x 1.550 mm
weight	5.060 kg	4.570 kg	7.720 kg

	E-3RBM PRO HS 2.050-13,0	E-3RBM PRO HS 2.550-8,0	E-3RBM PRO HS 2.550-13,0
<b>EAN</b>	<b>4260364291803</b>	<b>4260364291810</b>	<b>4260364291827</b>
<b>Item No.</b>	<b>355 2013</b>	<b>355 2580</b>	<b>355 2513</b>

Description	E-3RBM PRO HS 3.100-6,0	E-3RBM PRO HS 3.100-13,0	E-3RBM PRO HS 4.100-8,0
roller length	max. 3.100 mm	max. 3.100 mm	max. 4.100 mm
sheet thickness (St 37)	max. 6,0 mm	max. 13,0 mm	max. 8,0 mm
diameter of the upper rolls	210 mm	300 mm	300 mm
diameter of the lower rolls	190 mm	280 mm	280 mm
motor power	400 V / 50 Hz / 7,5 kW	400 V / 50 Hz / 11 kW	400 V / 50 Hz / 11 kW
roller speed	5 m/min	5 m/min	5 m/min
dimensions (L x D x H)	4.450 x 1.200 x 1.300 mm	5.150 x 1.500 x 1.550 mm	6.150 x 1.500 x 1.550 mm
weight	5.205 kg	9.900 kg	11.800 kg

	E-3RBM PRO HS 3.100-6,0	E-3RBM PRO HS 3.100-13,0	E-3RBM PRO HS 4.100-8,0
<b>EAN</b>	<b>4260364291834</b>	<b>4260364291841</b>	<b>4260364291858</b>
<b>Item No.</b>	<b>355 3160</b>	<b>355 3113</b>	<b>355 4180</b>

# E-3RBM PRO HSS - MODELS

## HYDRAULIC 3-ROLLER-ROUND BENDING MACHINES



**PREMIUM-LINE**



PIC: E-3RBM 3.100-25,0  
WITH OPTIONAL VERTICAL OVERHEADCRANE

For technical data check page 197.

When ordering please name the type of material which will be used

### E-3RBM PRO HSS - MODELS

- » fully hydraulic 3-roller round bending machine with high prebending performance
- » solid welded steel construction
- » hydraulic drive of all 3 rolls via planetary reduction gear
- » hydraulic compensation of the roll rotation speed
- » extended roll ends for the application of profile bending rolls
- » hardened rolls made of forged SAE-1050 quality steel
- » digital display for adjustable lower rolls as standard
- » conical bending device as standard

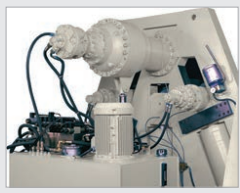

**hydraulic device**  
» With high-quality components  
» view without cladding



**drop end**  
» hydraulic drop end for rapid removal of the machined tubes (standard)

### OPTIONAL ACCESSORIES

- » various profile rolls
- » hydraulic support for large radius
- » hydraulic side support
- » hydraulic tube ejecting
- » ground and polished rolls

» bending performance data refer to 24 kg/m<sup>2</sup> sheet bending limit  
» sheet thickness for stainless steel: factor 0,5  
» sheet thickness for aluminum: factor 1,2

### Function scheme of the bending process

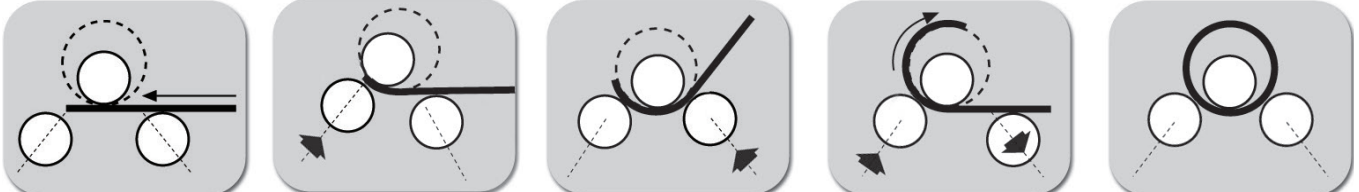



## E-3RBM PRO HSS - MODELS

### TECHNICAL DATA

Description	E-3RBM PRO HSS 2.050-30,0	E-3RBM PRO HSS 2.050-35,0	E-3RBM PRO HSS 2.550-25,0
roller length	max. 2.050 mm	max. 2.050 mm	max. 2.550 mm
sheet thickness (St 37)	max. 30,0 mm	max. 35,0 mm	max. 25,0 mm
diameter of the upper rolls	350 mm	380 mm	350 mm
diameter of the lower rolls	330 mm	360 mm	330 mm
motor power	400 V / 50 Hz / 22 kW	400 V / 50 Hz / 37 kW	400 V / 50 Hz / 22 kW
roller speed	1,5 / 5 m/min	1,5 / 5 m/min	1,5 / 5 m/min
dimensions (L x D x H)	4.600 x 2.000 x 1.750 mm	4.600 x 2.100 x 1.850 mm	5.100 x 2.000 x 1.750 mm
weight	10.600 kg	12.650 kg	12.000 kg
	<b>E-3RBM PRO HSS 2.050-30,0</b>	<b>E-3RBM PRO HSS 2.050-35,0</b>	<b>E-3RBM PRO HSS 2.550-25,0</b>
<b>EAN</b>	<b>4260364291865</b>	<b>4260364291872</b>	<b>4260364291889</b>
<b>Item No.</b>	<b>356 2030</b>	<b>356 2035</b>	<b>356 2525</b>

Description	E-3RBM PRO HSS 2.550-30,0	E-3RBM PRO HSS 3.100-20,0	E-3RBM PRO HSS 3.100-25,0
roller length	max. 2.550 mm	max. 3.100 mm	max. 3.100 mm
sheet thickness (St 37)	max. 30,0 mm	max. 20,0 mm	max. 25,0 mm
diameter of the upper rolls	380 mm	350 mm	380 mm
diameter of the lower rolls	360 mm	330 mm	360 mm
motor power	400 V / 50 Hz / 37 kW	400 V / 50 Hz / 22 kW	400 V / 50 Hz / 37 kW
roller speed	1,5 / 5 m/min	1,5 / 5 m/min	1,5 / 5 m/min
dimensions (L x D x H)	5.100 x 2.100 x 1.850 mm	5.650 x 2.000 x 1.750 mm	5.650 x 2.100 x 1.850 mm
weight	13.900 kg	13.000 kg	15.300 kg
	<b>E-3RBM PRO HSS 2.550-30,0</b>	<b>E-3RBM PRO HSS 3.100-20,0</b>	<b>E-3RBM PRO HSS 3.100-25,0</b>
<b>EAN</b>	<b>4260364291896</b>	<b>4260364291902</b>	<b>4260364291919</b>
<b>Item No.</b>	<b>356 2530</b>	<b>356 3120</b>	<b>356 3125</b>

Description	E-3RBM PRO HSS 4.100-12,0	E-3RBM PRO HSS 4.100-16,0	E-3RBM PRO HSS 4.100-20,0
roller length	max. 4.100 mm	max. 4.100 mm	max. 4.100 mm
sheet thickness (St 37)	max. 12,0 mm	max. 16,0 mm	max. 20,0 mm
diameter of the upper rolls	350 mm	380 mm	420 mm
diameter of the lower rolls	330 mm	360 mm	400 mm
motor power	400 V / 50 Hz / 22 kW	400 V / 50 Hz / 37 kW	400 V / 50 Hz / 37 kW
roller speed	1,5 / 5 m/min	1,5 / 5 m/min	1,5 / 5 m/min
dimensions (L x D x H)	6.650 x 2.000 x 1.750 mm	6.950 x 2.100 x 1.850 mm	6.750 x 2.250 x 2.250 mm
weight	14.800 kg	17.950 kg	23.320 kg
	<b>E-3RBM PRO HSS 4.100-12,0</b>	<b>E-3RBM PRO HSS 4.100-16,0</b>	<b>E-3RBM PRO HSS 4.100-20,0</b>
<b>EAN</b>	<b>4260364291926</b>	<b>4260364291933</b>	<b>4260364291940</b>
<b>Item No.</b>	<b>356 4112</b>	<b>356 4116</b>	<b>356 4120</b>

DRILLING

MILLING

TURNING

SAWING

GRINDING

BENDING

CUTTING /  
PRESSING

OTHER  
MACHINES

ACCESSORIES

# E-4RBM HS LINEAR - MODELS

## MOTORIZED 4-ROLLER ROUND BENDING MACHINES

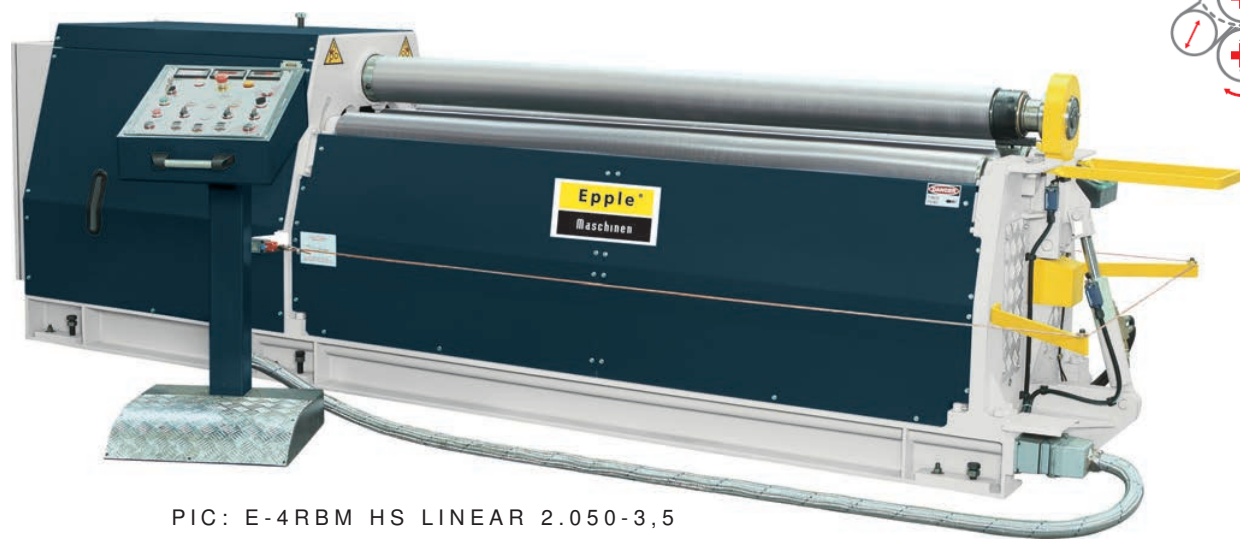
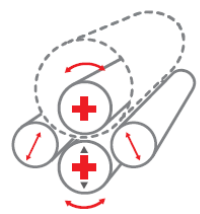

PIC: E-4RBM HS LINEAR 2.050-3,5  
(ON REQUEST)

### E-4RBM HS LINEAR - MODELS

- » top roller drive via planetary gear, side and bottom roller free-running, up and down movements are hydraulic
- » hydraulic folding bearing for easy removal of the rolled material
- » complete operation via a clearly arranged, mobile control panel
- » digital display for the lower roller and the side rollers
- » heavy welded steel construction
- » conical bending device (less sheet thickness), motorized adjustment of lower roll
- » central lubrication
- » induction-hardened forged steel rolls

### OPTIONAL ACCESSORIES

- » NC-control
- » hydraulic large radius support
- » hydraulic side support

» bending performance data refer to 24 kg/m<sup>2</sup> sheet bending limit  
 » sheet thickness for stainless steel: factor 0,5  
 » sheet thickness for aluminum: factor 1,2

**When ordering please include the processable Specify material type!**

### E-4RBM HS - MODELS - TECHNICAL DATA

Description	E-4RBM HS linear 1.050-2,5	E-4RBM HS linear 1.050-3,5	E-4RBM HS linear 1.050-4,5	E-4RBM HS linear 1.050-5,0
roller length	max. 1.050 mm	max. 1.050 mm	max. 1.050 mm	max. 1.050 mm
sheet thickness (St 37)	max. 2,5 mm	max. 3,5 mm	max. 4,5 mm	max. 5,0 mm
central rolls Ø	90 / 120 mm	100 / 120 mm	110 / 120 mm	120 / 130 mm
side rolls Ø	110 mm	110 mm	110 mm	130 mm
motor power	400 V / 50 Hz / 2,2 kW	400 V / 50 Hz / 2,2 kW	400 V / 50 Hz / 3,0 kW	400 V / 50 Hz / 5,0 kW
roller speed	1,5 - 6 m/min	1,5 - 6 m/min	1,5 - 6 m/min	1,5 - 6 m/min
dimensions (L x D x H)	3.100 x 1.000 x 1.100 mm	3.100 x 1.000 x 1.100 mm	3.100 x 1.000 x 1.100 mm	3.100 x 1.000 x 1.150 mm
weight	1.990 kg	2.010 kg	2.040 kg	2.330 kg
	<b>E-4RBM HS Linear 1.050-2,5</b>	<b>E-4RBM HS Linear 1.050-3,5</b>	<b>E-4RBM HS Linear 1.050-4,5</b>	<b>E-4RBM HS Linear 1.050-5,0</b>
<b>EAN</b>	4260657651550	4260657651567	4260657651574	4260657651581
<b>Item No.</b>	457 1025	457 1035	457 1045	457 1050

## E-4RBM HS LINEAR - MODELS

### TECHNICAL DATA

Description	E-4RBM HS linear 1.050-5,5	E-4RBM HS linear 1.050-7,0	E-4RBM HS linear 1.550-2,0	E-4RBM HS linear 1.550-3,0
roller length	max. 1.050 mm	max. 1.050 mm	max. 1.550 mm	max. 1.550 mm
sheet thickness (St 37)	max. 5,5 mm	max. 7,0 mm	max. 2,0 mm	max. 3,0 mm
central rolls Ø	130 / 130 mm	140 / 130 mm	90 / 120 mm	100 / 120 mm
side rolls Ø	130 mm	130 mm	110 mm	110 mm
motor power	400 V / 50 Hz / 3,0 kW	400 V / 50 Hz / 4,0 kW	400 V / 50 Hz / 2,2 kW	400 V / 50 Hz / 2,2 kW
roller speed	1,5 - 6 m/min	1,5 - 6 m/min	1,5 - 6 m/min	1,5 - 6 m/min
dimensions (L x D x H)	3.100 x 1.000 x 1.150 mm	3.100 x 1.000 x 1.150 mm	3.600 x 1.000 x 1.100 mm	3.600 x 1.000 x 1.100 mm
weight	2.350 kg	2.380 kg	2.150 kg	2.170 kg
Description	E-4RBM HS linear 1.050-5,5	E-4RBM HS linear 1.050-7,0	E-4RBM HS linear 1.550-2,0	E-4RBM HS linear 1.550-3,0
<b>EAN</b>	<b>4260657651598</b>	<b>4260657651604</b>	<b>4260657651611</b>	<b>4260657651628</b>
<b>Item No.</b>	<b>457 1055</b>	<b>457 1070</b>	<b>457 1520</b>	<b>457 1530</b>

Description	E-4RBM HS linear 1.550-3,5	E-4RBM HS linear 1.550-4,0	E-4RBM HS linear 1.550-4,5	E-4RBM HS linear 1.550-5,0
roller length	max. 1.550 mm	max. 1.550 mm	max. 1.550 mm	max. 1.550 mm
sheet thickness (St 37)	max. 3,5 mm	max. 4,0 mm	max. 4,5 mm	max. 5,0 mm
central rolls Ø	110 / 120 mm	120 / 130 mm	130 / 130 mm	140 / 130 mm
side rolls Ø	110 mm	130 mm	130 mm	130 mm
motor power	400 V / 50 Hz / 3,0 kW	400 V / 50 Hz / 3,0 kW	400 V / 50 Hz / 3,0 kW	400 V / 50 Hz / 4,0 kW
roller speed	1,5 - 6 m/min	1,5 - 6 m/min	1,5 - 6 m/min	1,5 - 6 m/min
dimensions (L x D x H)	3.600 x 1.000 x 1.100 mm	3.600 x 1.000 x 1.150 mm	3.600 x 1.000 x 1.150 mm	3.600 x 1.000 x 1.150 mm
weight	2.200 kg	2.410 kg	2.430 kg	2.460 kg
Description	E-4RBM HS linear 1.550-3,5	E-4RBM HS linear 1.550-4,0	E-4RBM HS linear 1.550-4,5	E-4RBM HS linear 1.550-5,0
<b>EAN</b>	<b>4260657651635</b>	<b>4260657651642</b>	<b>4260657651659</b>	<b>4260657651666</b>
<b>Item No.</b>	<b>457 1535</b>	<b>457 1540</b>	<b>457 1545</b>	<b>457 1550</b>

Description	E-4RBM HS linear 2.050-2,0	E-4RBM HS linear 2.050-3,0	E-4RBM HS linear 2.050-4,0	E-4RBM HS linear 2.050-4,5
roller length	max. 2.050 mm	max. 2.050 mm	max. 2.050 mm	max. 2.050 mm
sheet thickness (St 37)	max. 2,0 mm	max. 3,0 mm	max. 4,0 mm	max. 4,5 mm
central rolls Ø	110 / 120 mm	120 / 130 mm	130 / 130 mm	140 / 130 mm
side rolls Ø	110 mm	130 mm	130 mm	130 mm
motor power	400 V / 50 Hz / 3,0 kW	400 V / 50 Hz / 3,0 kW	400 V / 50 Hz / 3,0 kW	400 V / 50 Hz / 4,0 kW
roller speed	1,5 - 6 m/min	1,5 - 6 m/min	1,5 - 6 m/min	1,5 - 6 m/min
dimensions (L x D x H)	4.100 x 1.000 x 1.100 mm	4.100 x 1.000 x 1.150 mm	4.100 x 1.000 x 1.150 mm	4.100 x 1.000 x 1.150 mm
weight	2.360 kg	2.490 kg	2.510 kg	2.540 kg
Description	E-4RBM HS linear 2.050-2,0	E-4RBM HS linear 2.050-3,0	E-4RBM HS linear 2.050-4,0	E-4RBM HS linear 2.050-4,5
<b>EAN</b>	<b>4260657651673</b>	<b>4260657651680</b>	<b>4260657651697</b>	<b>4260657651703</b>
<b>Item No.</b>	<b>457 2020</b>	<b>457 2030</b>	<b>457 2040</b>	<b>457 2045</b>

DRILLING

MILLING

TURNING

SAWING

GRINDING

BENDING

CUTTING / PRESSING

OTHER MACHINES

ACCESSORIES

**E-4RBM 1.050-5,0 / E-4RBM 1.550-4,0**  
**E-4RBM 2.050-3,0**

**4-ROLLER-ROUND BENDING MACHINES**

**NEW**

**PREMIUM-LINE**



PIC: E-4RBM 1.550-4,0

**E-4RBM 1.050-5,0 / E-4RBM 1.550-4,0**  
**E-4RBM 2.050-3,0**

- » upper roller drive of the side and bottom roll; up and down movements are carried out with reduction gears
- » manual folding bearing for easy removal of the rolled material
- » control via mobile control panel
- » heavy steel welded construction
- » conical bending device
- » induction-hardened rolls of forged steel



- » **bending performance data refer to 24 kg/m<sup>2</sup> sheet bending limit**
- » **sheet thickness for stainless steel: factor 0,5**
- » **sheet thickness for aluminum: factor 1,2**

**When ordering please name the type of material which will be used**

Description	E-4RBM 1.050-5,0	E-4RBM 1.550-4,0	E-4RBM 2.050-3,0
roller length	max. 1.050 mm	max. 1.550 mm	max. 2.050 mm
sheet thickness (St 37)	max. 5,0 mm	max. 4,0 mm	max. 3,0 mm
diameter of the upper rolls	130 mm	130 mm	130 mm
diameter of the lower rolls	110 mm	110 mm	110 mm
motor power	400 V / 50 Hz / 2,2 kW	400 V / 50 Hz / 2,2 kW	400 V / 50 Hz / 2,2 kW
roller speed	5 m/min	5 m/min	5 m/min
dimensions (L x D x H)	2.500 x 900 x 850 mm	3.000 x 900 x 850 mm	3.500 x 900 x 850 mm
weight	1.300 kg	1.550 kg	1.900 kg
	<b>E-4RBM 1.050-5,0</b>	<b>E-4RBM 1.550-4,0</b>	<b>E-4RBM 2.050-3,0</b>
<b>EAN</b>	<b>4260364296471</b>	<b>4260364296488</b>	<b>4260364296495</b>
<b>Item No.</b>	<b>359 1055</b>	<b>359 1554</b>	<b>359 2053</b>

# E-4RBM-H NC - MODELS

## HYDRAULIC 4-ROLLER-ROUND BENDING MACHINES

**NEW**

**PREMIUM-LINE**

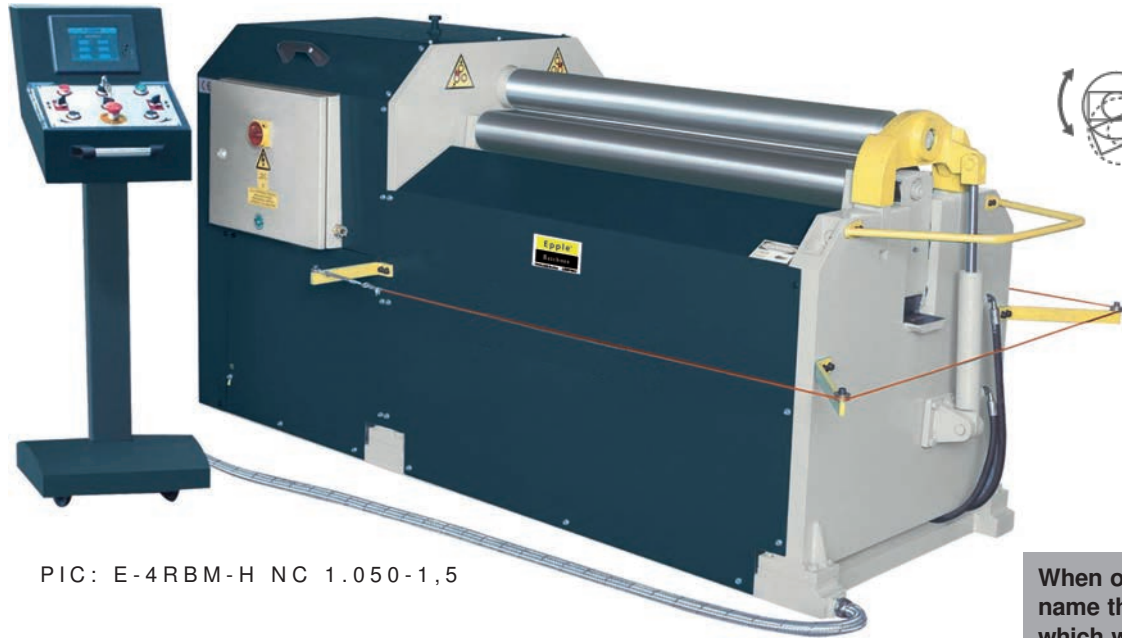

PIC: E-4RBM-H NC 1.050-1,5

When ordering please name the type of material which will be used

### E-4RBM-H NC - MODELS WITH NC CONTROL

- » top roller drive via planetary gear, side and bottom roller free-running, on and off downwards movements are hydraulic
- » hydraulic folding bearing for easy removal of the rolled material
- » complete operation via a clearly laid out mobile control panel
- » digital display for the lower roller and the side rollers
- » heavy welded steel construction
- » conical bending device (sheet thicknesses are smaller)
- » central lubrication
- » induction hardened rollers made of forged steel

Description	E-4RBM-H 1.050-1,5 NC	E-4RBM-H 1.050-2,5 NC
roller length	max. 1.050 mm	max. 1.050 mm
sheet thickness (St 37)	max. 1,5 mm	max. 2,5 mm
diameter of the central rolls	60 mm	90 mm
diameter of the side rolls	60 mm	100 mm
motor power	400 V / 50 Hz / 1,1 kW	400 V / 50 Hz / 2,2 kW
roller speed	4,5 m/min	4,5 m/min
dimensions (L x D x H)	2.050 x 875 x 1.060 mm	2.250 x 1.000 x 1.500 mm
weight	720 kg	900 kg
	<b>E-4RBM-H 1.050-1,5 NC</b>	<b>E-4RBM-H 1.050-2,5 NC</b>
<b>EAN</b>	<b>4260364296549</b>	<b>4260364296556</b>
<b>Item No.</b>	<b>357 2015</b>	<b>357 1025</b>

Description	E-4RBM-H 1.050-5,0 NC	E-4RBM-H 1.550-2,0 NC	E-4RBM-H 1.550-4,0 NC
roller length	max. 1.050 mm	max. 1.550 mm	max. 1.550 mm
sheet thickness (St 37)	max. 5,0 mm	max. 2,0 mm	max. 4,0 mm
diameter of the central rolls	130 mm	90 mm	130 mm
diameter of the side rolls	110 mm	100 mm	110 mm
motor power	400 V / 50 Hz / 3 kW	400 V / 50 Hz / 2,2 kW	400 V / 50 Hz / 3 kW
roller speed	4,5 m/min	4,5 m/min	5 m/min
dimensions (L x D x H)	2.250 x 1.000 x 1.500 mm	2.750 x 1.000 x 1.500 mm	2.750 x 1.000 x 1.500 mm
weight	1.560 kg	1.100 kg	1.760 kg
	<b>E-4RBM-H 1.050-5,0 NC</b>	<b>E-4RBM-H 1.550-2,0 NC</b>	<b>E-4RBM-H 1.550-4,0 NC</b>
<b>EAN</b>	<b>4260364296563</b>	<b>4260364296570</b>	<b>4260364296587</b>
<b>Item No.</b>	<b>357 1050</b>	<b>357 1520</b>	<b>357 1540</b>

- » bending performance data refer to 24 kg/m<sup>2</sup> sheet bending limit
- » sheet thickness for stainless steel: factor 0,5
- » sheet thickness for aluminum: factor 1,2

The machines are also available for other sheet thicknesses.

DRILLING

MILLING

TURNING

SAWING

GRINDING

BENDING

CUTTING / PRESSING

OTHER MACHINES

ACCESSORIES



**E-4RBM PRO HMS - MODELS**  
HYDRAULIC 4-ROLLER-ROUND BENDING MACHINES

**PREMIUM-LINE**

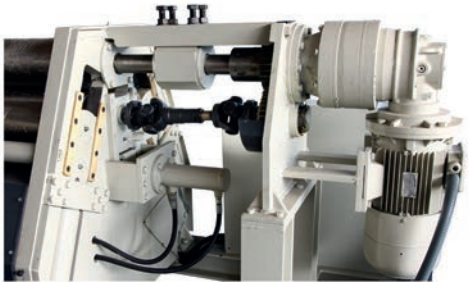

PIC: E-4RBM PRO HMS 650-3,5  
(ON REQUEST: E-4RBM PRO HMS 1.550-8,0)

For technical data check page 204 - 205.

**E-4RBM PRO HMS - MODELS**

- » top roller driven by electric motor with gear
- » clamping roller and side roller hydraulically driven
- » hydraulic hinged bearing for easy removal of the rolled material
- » digital display of lower roll and both side rolls
- » complete operation via a clearly arranged, mobile control panel
- » heavy welded steel construction
- » conical bending device (sheet thickness less), motorized adjustment of lower roller
- » central lubrication
- » hydraulic balance system
- » induction hardened rolls made of forged steel

When ordering please name the type of material which will be used

- » bending performance data refer to 24 kg/m<sup>2</sup> sheet bending limit
- » sheet thickness for stainless steel: factor 0,5
- » sheet thickness for aluminum: factor 1,2



PIC: E-4RBM PRO HMS 1.550-8,0  
OPTIONAL WITH HYDRAULIC SUPPORT FOR LARGE RADIUS

**OPTIONAL ACCESSORIES**

- » NC control
- » hydraulic support for large radius
- » hydraulic side support
- » hydraulic tube ejection
- » ground and polished rolls

# E-4RBM PRO HMS - MODELS

HYDRAULIC 4-ROLLER-ROUND BENDING MACHINE

OPTIONAL SEMI- OR FULLY AUTOMATIC FOR SERIAL PRODUCTION

**PREMIUM-LINE**



PIC: E-4RBM PRO HMS  
FULLY AUTOMATIC WITH ACCESSORIES

## E-4RBM PRO HMS - MODELS

Hydraulic 4-roller-round bending machine for processing light and medium plate thickness, also for aluminum and stainless steel.

- » heavy and robust, welded construction
- » drive top roller via electric motor and planetary gear
- » drive clamping roller via cardan joint system
- » overload protection
- » linear infeed of the clamping and side rollers by means of hydraulic cylinder
- » rolls induction hardened
- » triple digital display of the roller position
- » conical bending device
- » hydraulic folding bearing for removal of finished parts
- » mobile control panel

**When ordering please name the type of material which will be used**

- » bending performance data refer to 24 kg/m<sup>2</sup> sheet bending limit
- » sheet thickness for stainless steel: factor 0,5
- » sheet thickness for aluminum: factor 1,2

## OPTIONAL ACCESSORIES

- » teach-in-control
- » easy to operate 4-axis NC-control, expandable to 7 axes
- » teach-In-Input
- » 16 languages
- » up to 1.000 programs can be stored via USB
- » stepless adjustment of the bending speed
- » double speed for automation
- » grounded and polished rollers
- » overhead crane for large diameters
- » hydraulic lateral supports for large diameter
- » material feeding system with vacuum lifter
- » automatic bending via NC control
- » ejector system

For technical data check page 204 - 205.

DRILLING

MILLING

TURNING

SAWING

GRINDING

BENDING

CUTTING / PRESSING

OTHER MACHINES

ACCESSORIES

## E-4RBM PRO HMS - MODELS

### TECHNICAL DATA

Description	E-4RBM PRO HMS 650-3,5	E-4RBM PRO HMS 1.050-1,0	E-4RBM PRO HMS 1.050-2,5
roller length	max. 650 mm	max. 1.050 mm	max. 1.050 mm
sheet thickness (St 37)	max. 3,5 mm	max. 1,0 mm	max. 2,5 mm
diameter of upper/lower rollers	80 mm	60 mm	80 mm
diameter of the side rollers	80 mm	60 mm	80 mm
motor power	400 V / 50 Hz / 1,9 kW	400 V / 50 Hz / 1,9 kW	400 V / 50 Hz / 1,9 kW
roller speed	5 m/min	5 m/min	5 m/min
dimensions (L x D x H)	1.950 x 950 x 960 mm	1.850 x 650 x 760 mm	2.350 x 950 x 960 mm
weight	950 kg	850 kg	1.150 kg
	<b>E-4RBM PRO HMS 650-3,5</b>	<b>E-4RBM PRO HMS 1.050-1,0</b>	<b>E-4RBM PRO HMS 1.050-2,5</b>
<b>EAN</b>	<b>4260364296594</b>	<b>4260657650614</b>	<b>4260657650621</b>
<b>Item No.</b>	<b>359 0635</b>	<b>359 1010</b>	<b>359 1025</b>

Description	E-4RBM PRO HMS 1.050-5,0	E-4RBM PRO HMS 1.270-3,0	E-4RBM PRO HMS 1.270-7,0
roller length	max. 1.050 mm	max. 1.270 mm	max. 1.270 mm
sheet thickness (St 37)	max. 5,0 mm	max. 3,0 mm	max. 7,0 mm
diameter of upper/lower rollers	130 mm	100 mm	150 mm
diameter of the side rollers	130 mm	90 mm	130 mm
motor power	400 V / 50 Hz / 3,3 kW	400 V / 50 Hz / 1,9 kW	400 V / 50 Hz / 3,3 kW
roller speed	5 m/min	6,5 m/min	6 m/min
dimensions (L x D x H)	2.770 x 1.150 x 1.100 mm	2.570 x 950 x 960 mm	3.020 x 1.150 x 1.110 mm
weight	2.050 kg	1.350 kg	2.155 kg
	<b>E-4RBM PRO HMS 1.050-5,0</b>	<b>E-4RBM PRO HMS 1.270-3,0</b>	<b>E-4RBM PRO HMS 1.270-7,0</b>
<b>EAN</b>	<b>4260364296600</b>	<b>4260364296617</b>	<b>4260364296624</b>
<b>Item No.</b>	<b>359 1050</b>	<b>359 1230</b>	<b>359 1270</b>

Description	E-4RBM PRO HMS 1.270-10,0	E-4RBM PRO HMS 1.550-1,5	E-4RBM PRO HMS 1.550-4,5
roller length	max. 1.270 mm	max. 1.550 mm	max. 1.550 mm
sheet thickness (St 37)	max. 10,0 mm	max. 1,5 mm	max. 4,5 mm
diameter of upper/lower rollers	200 mm	80 mm	150 mm
diameter of the side rollers	180 mm	80 mm	130 mm
motor power	400 V / 50 Hz / 4 kW	400 V / 50 Hz / 1,9 kW	400 V / 50 Hz / 2,2 kW
roller speed	6 m/min	5 m/min	6 m/min
dimensions (L x D x H)	3.070 x 1.350 x 1.290 mm	2.850 x 950 x 960 mm	3.300 x 1.150 x 1.110 mm
weight	3.000 kg	1.350 kg	2.370 kg
	<b>E-4RBM PRO HMS 1.270-10,0</b>	<b>E-4RBM PRO HMS 1.550-1,5</b>	<b>E-4RBM PRO HMS 1.550-4,5</b>
<b>EAN</b>	<b>4260364299458</b>	<b>4260657650638</b>	<b>4260364299465</b>
<b>Item No.</b>	<b>359 1210</b>	<b>359 1515</b>	<b>359 1545</b>

The machines are also available for other sheet thicknesses.

## E-4RBM PRO HMS - MODELS

### TECHNICAL DATA

Description	E-4RBM PRO HMS 1.550-6,5	E-4RBM PRO HMS 1.550-9,0	E-4RBM PRO HMS 1.550-12,0
roller length	max. 1.550 mm	max. 1.550 mm	max. 1.550 mm
sheet thickness (St 37)	max. 6,5 mm	max. 9,0 mm	max. 12,0 mm
diameter of upper/lower rollers	150 mm	180 mm	250 mm
diameter of the side rollers	130 mm	150 mm	200 mm
motor power	400 V / 50 Hz / 3,3 kW	400 V / 50 Hz / 5,5 kW	400 V / 50 Hz / 7,5 kW
roller speed	6 m/min	5 m/min	5 m/min
dimensions (L x D x H)	3.300 x 1.150 x 1.310 mm	3.350 x 1.350 x 1.290 mm	3.500 x 1.500 x 1.370 mm
weight	2.370 kg	2.900 kg	4.650 kg
	<b>E-4RBM PRO HMS 1.550-6,5</b>	<b>E-4RBM PRO HMS 1.550-9,0</b>	<b>E-4RBM PRO HMS 1.550-12,0</b>
<b>EAN</b>	<b>4260657650645</b>	<b>4260657650652</b>	<b>4260364299472</b>
<b>Item No.</b>	<b>359 1565</b>	<b>359 1590</b>	<b>359 1512</b>

Description	E-4RBM PRO HMS 2.050-6,0	E-4RBM PRO HMS 2.050-8,0	E-4RBM PRO HMS 2.050-10,0
roller length	max. 2.050 mm	max. 2.050 mm	max. 2.050 mm
sheet thickness (St 37)	max. 6,0 mm	max. 8,0 mm	max. 10,0 mm
diameter of upper/lower rollers	180 mm	200 mm	250 mm
diameter of the side rollers	150 mm	180 mm	200 mm
motor power	400 V / 50 Hz / 4 kW	400 V / 50 Hz / 5,5 kW	400 V / 50 Hz / 7,5 kW
roller speed	5 m/min	6 m/min	5 m/min
dimensions (L x D x H)	3.850 x 1.350 x 1.290 mm	3.850 x 1.350 x 1.290 mm	4.000 x 1.500 x 1.370 mm
weight	3.300 kg	3.750 kg	5.350 kg
	<b>E-4RBM PRO HMS 2.050-6,0</b>	<b>E-4RBM PRO HMS 2.050-8,0</b>	<b>E-4RBM PRO HMS 2.050-10,0</b>
<b>EAN</b>	<b>4260364299489</b>	<b>4260657650669</b>	<b>4260364299496</b>
<b>Item No.</b>	<b>359 2060</b>	<b>359 2080</b>	<b>359 2010</b>

Description	E-4RBM PRO HMS 2.550-8,0	E-4RBM PRO HMS 3.100-4,0	E-4RBM PRO HMS 3.100-7,0
roller length	max. 2.550 mm	max. 3.100 mm	max. 3.100 mm
sheet thickness (St 37)	max. 8,0 mm	max. 4,0 mm	max. 7,0 mm
diameter of upper/lower rollers	250 mm	180 mm	250 mm
diameter of the side rollers	200 mm	150 mm	200 mm
motor power	400 V / 50 Hz / 7,5 kW	400 V / 50 Hz / 5,5 kW	400 V / 50 Hz / 7,5 kW
roller speed	5 m/min	5 m/min	5 m/min
dimensions (L x D x H)	4.500 x 1.500 x 1.370 mm	4.850 x 1.350 x 1.290 mm	5.000 x 1.500 x 1.370 mm
weight	6.100 kg	4.100 kg	6.800 kg
	<b>E-4RBM PRO HMS 2.550-8,0</b>	<b>E-4RBM PRO HMS 3.100-4,0</b>	<b>E-4RBM PRO HMS 3.100-7,0</b>
<b>EAN</b>	<b>4260364299519</b>	<b>4260657650676</b>	<b>4260364299526</b>
<b>Item No.</b>	<b>359 2580</b>	<b>359 3140</b>	<b>359 3170</b>

The machines are also available for other sheet thicknesses.

DRILLING

MILLING

TURNING

SAWING

GRINDING

BENDING

CUTTING /  
PRESSING

OTHER  
MACHINES

ACCESSORIES

# E-4RBM PRO HS - MODELS

## MOTORIC 4-ROLLER-ROUND BENDING MACHINES

**PREMIUM-LINE**

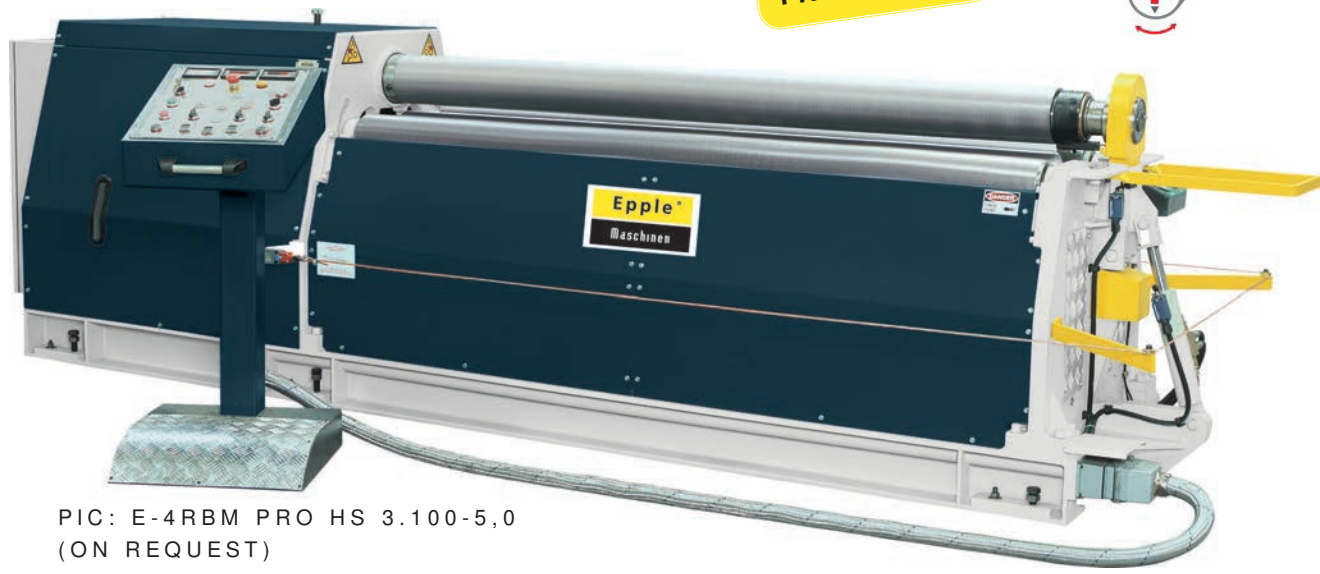
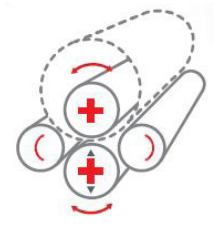

PIC: E-4RBM PRO HS 3.100-5,0  
 (ON REQUEST)

### E-4RBM PRO HS - MODELS

- » top roller drive via planetary gearbox, side and bottom roller free-running, upward and downward movements are made hydraulically
- » side roll movement is circular
- » hydraulic folding bearing for easy removal of the rolled material
- » complete operation via a clearly arranged, mobile control panel
- » digital display for the bottom roll and the side rolls
- » heavy steel welded construction
- » conical bending device (sheet thickness less), motorized adjustment of bottom roll
- » central lubrication
- » induction hardened forged steel rolls

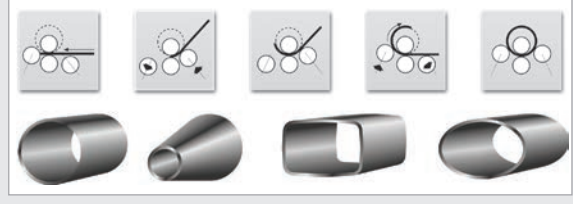

### OPTIONAL EQUIPMENT

- » NC control
- » hydraulic support for large radius
- » hydraulic side support

» bending performance data refer to 24 kg/m<sup>2</sup> sheet bending limit  
 » sheet thickness for stainless steel: factor 0,5  
 » sheet thickness for aluminum: factor 1,2

**When ordering please name the type of material which will be used**

Description	E-4RBM PRO HS 1.550-8,0	E-4RBM PRO HS 2.050-10,0	E-4RBM PRO HS 2.050-13,0	E-4RBM PRO HS 2.550-10,0	E-4RBM PRO HS 2.550-13,0
roller length	max. 1.550 mm	max. 2.050 mm	max. 2.050 mm	max. 2.550 mm	max. 2.550 mm
sheet thickness (St 37)	max. 8,0 mm	max. 10,0 mm	max. 13,0 mm	max. 10,0 mm	max. 13,0 mm
diameter of the central rolls	170 / 160 mm	220 mm	245 mm	245 mm	260 mm
diameter of the side rolls	150 mm	160 mm	180 mm	180 mm	200 mm
motor power	400 V / 50 Hz / 4 kW	400 V / 50 Hz / 5,5 kW	400 V / 50 Hz / 7,5 kW	400 V / 50 Hz / 7,5 kW	400 V / 50 Hz / 7,5 kW
roller speed	1,5 / 6 m/min	1,5 / 6 m/min	1,5 / 6 m/min	1,5 / 6 m/min	1,5 / 5 m/min
dimensions (L x D x H) in mm	3.600 x 860 x 1.150 mm	3.750 x 1.180 x 1.300 mm	4.000 x 1.550 x 1.500 mm	4.500 x 1.550 x 1.500 mm	4.500 x 1.590 x 1.600 mm
weight	2.500 kg	4.000 kg	5.100 kg	6.100 kg	6.740 kg
	<b>E-4RBM PRO HS 1.550-8,0</b>	<b>E-4RBM PRO HS 2.050-10,0</b>	<b>E-4RBM PRO HS 2.050-13,0</b>	<b>E-4RBM PRO HS 2.550-10,0</b>	<b>E-4RBM PRO HS 2.550-13,0</b>
EAN	4260364291957	4260364291964	4260364291971	4260364291988	4260364291995
Item No.	357 1580	357 2010	357 2013	357 2510	357 2513



# E-4KRB-H 1.050-3,0 / E-4KRB-H 1.050-4,0 CONIC 4-ROLLER-ROUND BENDING MACHINES



PIC: E-4KRB-H 1.050-3,0

**PREMIUM-LINE**



## E-4KRB-H 1.050-3,0 / E-4KRB-H 1.050-4,0

- » the drive of the rolls is given by electric motor with planetary gear
- » hydraulic upward and downward movement
- » hydraulic bearing cap for easy removal of the rolled material
- » entire operation via clear and mobile control panel
- » digital display for roll position
- » heavy welded steel construction
- » central lubrication
- » induction hardened, polished steel rolls (SAE-1050)

- » **bending performance data refer to 24 kg/m<sup>2</sup> sheet bending limit**
- » **sheet thickness for stainless steel: factor 0,5**
- » **sheet thickness for aluminum: factor 1,2**

When ordering please name the type of material which will be used

Description	E-4KRB-H 1.050-3,0	E-4KRB-H 1.050-4,0
roller length	max. 1.050 mm	max. 1.050 mm
sheet thickness (St 37)	max. 3,0 mm	max. 4,0 mm
biggest roller Ø	155 mm	185 mm
smallest roller Ø	40 mm	70 mm
min. bending diameter	63 mm	105 mm
motor power	400 V / 50 Hz / 3,7 kW	400 V / 50 Hz / 5,5 kW
roller speed	5 m/min	5 m/min
dimensions (L x D x H)	3.200 x 1.150 x 1.100 mm	2.800 x 1.250 x 1.170 mm
weight	2.000 kg	2.500 kg
	<b>E-4KRB-H 1.050-3,0</b>	<b>E-4KRB-H 1.050-4,0</b>
<b>EAN</b>	<b>4260364296457</b>	<b>4260364296464</b>
<b>Item No.</b>	<b>357 1030</b>	<b>357 1040</b>



PIC: SHOWS AN EXAMPLE OF A FINAL PRODUCT

# E-4RBM PRO HSS - MODELS

## MOTORIC 4-ROLLER-ROUND BENDING MACHINES

**PREMIUM-LINE**



PIC: E-4RBM PRO HSS 3.100-20,0  
(ON REQUEST)



### E-4RBM PRO HSS - MODELS

- » hydraulic drive of upper and side rolls, also for up and down movements
- » side rolls in pyramid system (reliable parallelism for precise bending by the lower and side rolls)
- » 2-speed levels to be chosen on the control panel
- » digital display of both side rolls and lower roll
- » hydraulic drop end for easy removal of the machined sheets
- » all operations controlled by functionally designed movable panel
- » conic bending device as standard
- » central lubrication as standard
- » induction hardened rolls made of forged steel

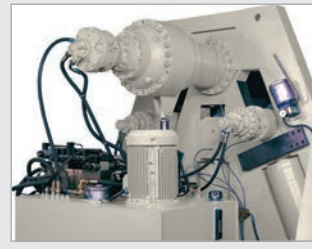

**hydraulic device**  
» with high quality components  
(view without cover)



» bending performance data refer to 24 kg/m<sup>2</sup> sheet bending limit  
» sheet thickness for stainless steel: factor 0,5  
» sheet thickness for aluminum: factor 1,2

When ordering please name the type of material which will be used

Description	E-4RBM PRO HSS 2.050-20,0	E-4RBM PRO HSS 2.050-40,0	E-4RBM PRO HSS 2.050-60,0	E-4RBM PRO HSS 2.550-16,0
roller length	max. 2.050 mm	max. 2.050 mm	max. 2.050 mm	max. 2.550 mm
sheet thickness (St 37)	max. 20,0 mm	max. 40,0 mm	max. 60,0 mm	max. 16,0 mm
diameter of the central rolls	280 mm	380 mm	550 mm	280 mm
diameter of the side rolls	220 mm	300 mm	450 mm	220 mm
motor power	400 V / 50 Hz / 16,5 kW	400 V / 50 Hz / 31,5 kW	400 V / 50 Hz / 66,0 kW	400 V / 50 Hz / 16,5 kW
roller speed	1,5 / 5 m/min	1,5 / 5 m/min	1,0 / 4 m/min	1,5 / 5 m/min
dimensions (L x D x H)	4.850 x 1.700 x 1.850 mm	4.900 x 2.250 x 2.350 mm	5.700 x 2.900 x 2.950 mm	5.300 x 1.700 x 1.850 mm
weight	8.550 kg	15.800 kg	40.000 kg	9.200 kg
	<b>E-4RBM PRO HSS 2.050-20,0</b>	<b>E-4RBM PRO HSS 2.050-40,0</b>	<b>E-4RBM PRO HSS 2.050-60,0</b>	<b>E-4RBM PRO HSS 2.550-16,0</b>
<b>EAN</b>	4260364296501	4260364296518	4260364296532	4260364296525
<b>Item No.</b>	358 2020	358 2040	358 2060	358 2516

## OPTIONAL EQUIPMENT

- » NC control
- » hydraulic support for large radius
- » hydraulic side support
- » hydraulic tube ejection
- » ground and polished rolls



## E-4RBM PRO HSS - MODELS

### TECHNICAL DATA

When ordering please name the type of material which will be used

Description	E-4RBM PRO HSS 2.550-20,0	E-4RBM PRO HSS 2.550-25,0	E-4RBM PRO HSS 3.100-12,0
roller length	max. 2.550 mm	max. 2.550 mm	max. 3.100 mm
sheet thickness (St 37)	max. 20,0 mm	max. 25,0 mm	max. 12,0 mm
diameter of the central rolls	320 mm	350 mm	280 mm
diameter of the side rolls	240 mm	260 mm	220 mm
motor power	400 V / 50 Hz / 20,0 kW	400 V / 50 Hz / 23,5 kW	400 V / 50 Hz / 16,5 kW
roller speed	1,5 / 5 m/min	1,5 / 5 m/min	1,5 / 5 m/min
dimensions (L x D x H)	5.400 x 1.800 x 1.950 mm	5.400 x 1.900 x 1.950 mm	5.850 x 1.700 x 1.850 mm
weight	11.750 kg	13.000 kg	10.000 kg
	<b>E-4RBM PRO HSS 2.550-20,0</b>	<b>E-4RBM PRO HSS 2.550-25,0</b>	<b>E-4RBM PRO HSS 3.100-12,0</b>
<b>EAN</b>	<b>4260364292008</b>	<b>4260364297232</b>	<b>4260364292015</b>
<b>Item No.</b>	<b>358 2520</b>	<b>358 2525</b>	<b>358 3112</b>

Description	E-4RBM PRO HSS 3.100-20,0	E-4RBM PRO HSS 3.100-25,0	E-4RBM PRO HSS 4.100-8,0
roller length	max. 3.100 mm	max. 3.100 mm	max. 4.100 mm
sheet thickness (St 37)	max. 20,0 mm	max. 25,0 mm	max. 8,0 mm
diameter of the central rolls	350 mm	380 mm	280 mm
diameter of the side rolls	260 mm	300 mm	220 mm
motor power	400 V / 50 Hz / 23,5 kW	400 V / 50 Hz / 31,5 kW	400 V / 50 Hz / 16,5 kW
roller speed	1,5 / 5 m/min	1,5 / 5 m/min	1,5 / 5 m/min
dimensions (L x D x H)	5.850 x 1.900 x 1.950 mm	5.850 x 2.250 x 2.350 mm	6.850 x 1.700 x 1.850 mm
weight	15.000 kg	18.800 kg	13.000 kg
	<b>E-4RBM PRO HSS 3.100-20,0</b>	<b>E-4RBM PRO HSS 3.100-25,0</b>	<b>E-4RBM PRO HSS 4.100-8,0</b>
<b>EAN</b>	<b>4260364292022</b>	<b>4260364292039</b>	<b>4260364292046</b>
<b>Item No.</b>	<b>358 3120</b>	<b>358 3125</b>	<b>358 4180</b>

## PW 10 M / PW 30 / PW 30 HV

### PROFILE ROLLER MACHINES



PIC: PW 10 M



PIC: PW 30



PIC: PW 30 HV

#### PW 10 M / PW 30 / PW 30 HV

- » solid frame made of cast iron
- » drive over hand crank
- » gearwheel milled from solid
- » hardened and ground rollers
- » arbors made of special steel, hardened and ground
- » millimeter scale for adjusting the pressure rollers
- » polished and double-based drive shafts that rotate in opposite tapered roller bearings
- » central block in one piece sliding on hardened slide shoes
- » the sliding blocks are housed on the machine frame
- » longitudinal workpiece storage and alignment devices
- » mechanical service, 2 slaving rollers

Description	PW 10 M	PW 30	PW 30 HV
axle diameter	30 mm	30 mm	30 mm
roller diameter	100 mm	118 - 148 mm	118 - 148 mm
head foldable for horizontal use	no	no	yes
motor power	-	400 V / 50 Hz / 1,1 kW	400 V / 50 Hz / 0,75 kW
roller speeds	-	4 U/min	4 U/min
dimensions (L x D x H)	580 x 550 x 1.470 mm	620 x 480 x 1.360 mm	1.000 x 620 x 1.360 mm
weight	158 kg	213 kg	224 kg
	<b>PW 10 M</b>	<b>PW 30</b>	<b>PW 30 HV</b>
EAN	4260364292053	4260364292060	4260364292077
Item No.	225 0030	225 1030	225 1530



# PW 40 HV / PW 50 PROFILE ROLLER MACHINES



PIC: PW 40 HV



PIC: PW 50

## PW 40 HV / PW 50

- » heavy version
- » millimetre scale for setting the printing rollers
- » width for round steel, square steel and tubes up to 30 mm stepless adjustable (with standard roller set supplied)
- » grounded and double-supported drive shafts, which rotate in opposite taper bearings
- » central block sliding on hardened sliding shoes from one piece
- » the hardened and grounded glide shoes are accommodated on the machine frame
- » longitudinal fixtures for workpiece deposit and alignment
- » mechanical infeed, 2 driven rollers

Description	PW 40 HV	PW 50
axis diameter	40 mm	50 mm
roller diameter	126 - 168 mm	190 mm
head foldable for horizontal use	yes	no
motor power	400 V / 50 Hz / 1,5 kW	400 V / 50 Hz / 2,2 kW
dimensions (L x D x H)	1.560 x 1.240 x 860 mm	840 x 750 x 1.450 mm
weight	425 kg	450 kg
	<b>PW 40 HV</b>	<b>PW 50</b>
<b>EAN</b>	<b>4260364292176</b>	<b>4260364292268</b>
<b>Item No.</b>	<b>225 1540</b>	<b>225 1050</b>

## ROLLER SETS



- » roller sets for specific dimensions on page 213
- » optional sets of plastic rollers on request



## PW 10 ROLLER SET INCLUDED IN DELIVERY

Profile	Dimensions in mm	min $\varnothing$ in mm
	10 x 10 20 x 20	190 500
	20 x 5 50 x 10	160 400
	20 x 5 30 x 10	190 500

## PW 30 / PW 30 HV ROLLER SET INCLUDED IN DELIVERY











Profile	PW 30 Dimensions in mm	PW 30 min $\varnothing$ in mm
	$\varnothing$ 20 x 1 $\varnothing$ 30 x 1	500 800
	$\varnothing$ 16	400
	20 x 20 x 1 30 x 30 x 1	800 900
	20 x 10 30 x 10	320 320

Profile	PW 30 HV Dimensions in mm	PW 30 HV min $\varnothing$ in mm
	40 x 40 x 3	1.000
	50 x 15	350
	50 x 30 x 3	1.200

## PW 30 HV OPTIONAL STEEL ROLLER SETS

Profile	Dimensions in mm	min $\varnothing$ in mm
	$\varnothing$ 15 $\varnothing$ 20 $\varnothing$ 25 $\varnothing$ 30	600
	40 x 40 x 2 40 x 40 x 3 40 x 40 x 4 40 x 40 x 5	400
	40 x 40 x 2 40 x 40 x 3 40 x 40 x 4 40 x 40 x 5	400
	50 x 50 x 2 50 x 50 x 3 50 x 50 x 4 50 x 50 x 5	400
	50 x 25 x 2 50 x 25 x 3 50 x 25 x 4 50 x 25 x 5	300
	50 x 25 x 2 50 x 25 x 3 50 x 25 x 4 50 x 25 x 5	400
	50 x 25 x 2 50 x 25 x 3 50 x 25 x 4 50 x 25 x 5	300
	$\varnothing$ 35 x 2 $\varnothing$ 40 x 2 $\varnothing$ 45 x 2 $\varnothing$ 50 x 2 $\varnothing$ 55 x 2 $\varnothing$ 60 x 2	600 500

# PW 40 HV / PW 50 ROLLER SET INCLUDED IN DELIVERY

Profile	PW 40 HV Dimensions in mm	PW 40 HV min $\phi$ in mm	PW 50 Dimensions in mm	PW 50 min $\phi$ in mm
	30 x 30 10 x 10 (continuously adjustable)	650 1.100	35 x 35 20 x 20	600 780
	60 x 20 30 x 6	800 1.250	60 x 10 40 x 10	500 650
	50 x 10 20 x 6	600 800	100 x 15 60 x 10	920 1.150
	$\phi$ 30 $\phi$ 10	650 1.100	$\phi$ 35 $\phi$ 30	600 650
	50 x 5 30 x 4	500 500	60 x 5 50 x 5	500 500
	50 x 5 30 x 4	500 500	60 x 5 50 x 5	700 700
	50 x 6 30 x 3	600 500	60 x 7 50 x 5	750 500
	50 x 6 30 x 3	600 500	60 x 7 50 x 5	750 700
	60 x 40 x 6 30 x 15 x 4	600 900	80 x 45 x 6 85 x 40 x 5	600 550
	60 x 40 x 6 30 x 15 x 4	600 900	80 x 45 x 6 65 x 40 x 5	650 550

PLASTIC - ROLLER SETS AND SETS FOR CUSTOMS ON REQUEST

# PW 40 HV / PW 50 OPTIONAL STEEL ROLLER SETS

Profile	PW 40 HV Dimensions in mm	PW 40 HV min $\phi$ in mm	PW 50 Dimensions in mm	PW 50 min $\phi$ in mm
	$\phi$ 30 x 2 $\phi$ 35 x 2 $\phi$ 40 x 2 $\phi$ 45 x 2 $\phi$ 50 x 2 $\phi$ 55 x 2 $\phi$ 60 x 2 $\phi$ 65 x 2 $\phi$ 70 x 2	700	$\phi$ 30 x 2 $\phi$ 55 x 2 $\phi$ 35 x 2 $\phi$ 60 x 2 $\phi$ 40 x 2 $\phi$ 65 x 2 $\phi$ 45 x 2 $\phi$ 70 x 2 $\phi$ 50 x 2	600

# E-PW 31 F / E-PW 35 F

## PROFILE ROLLER MACHINES

**PREMIUM-LINE**



PIC: E-PW 31 F



PIC: E-PW 35 F

Profile Roller Machines

### E-PW 31 F / E-PW 35 F WITH FOOT CONTROL

- » heavy and solid construction
- » 2 powered rolls
- » horizontally and vertically applicable  
(E-PW 31 F only vertically)
- » sideways mangle rolls, stepless adjustable for spiral bending
- » special hardened bending rolls
- » hardened and ground shaft of special steel
- » foot operating

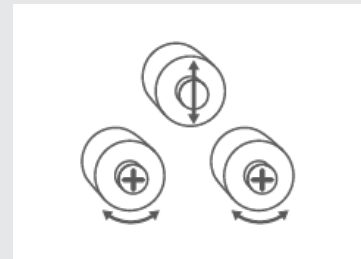

Description	E-PW 31 F	E-PW 35 F
axis diameter	30 mm	50 mm
upper rolls - diameter	148 mm	155 mm
lower rolls - diameter	118 mm	155 mm
horizontal working	-	yes
speed	2 - 4 m/min	4,5 m/min
motor power	400 V / 50 Hz / 0,85 kW	400 V / 50 Hz / 1,5 kW
dimensions (L x D x H)	800 x 600 x 1.450 mm	750 x 1.000 x 1.400 mm
weight	220 kg	400 kg
	<b>E-PW 31 F</b>	<b>E-PW 35 F</b>
<b>EAN</b>	4260364296631	4260364292275
<b>Item No.</b>	351 0031	351 0035

# E-PW 40 H / E-PW 50 H / E-PW 60 H

## HYDRAULIC PROFILE ROLLER MACHINES

**PREMIUM-LINE**



PIC: E-PW 40 H

PIC: E-PW 50 H

PIC: E-PW 60 H

### E-PW 40 H / E-PW 50 H / E-PW 60 H WITH FOOT CONTROL

- » heavy construction
- » hydraulic adjustment of the upper roll
- » 3 driven rolls
- » horizontal and vertical bending (machine inclinable)
- » hardened standard rolls
- » shafts are hardened and ground
- » stepless adjustable lateral rolls for spiral bending
- » brake motor equipped
- » control panel with foot control

The model **E-PW 40 H** is particularly suitable for smaller diameters and has 2 additional guide rollers for this purpose. The machine has a control panel with digital display for two axes.

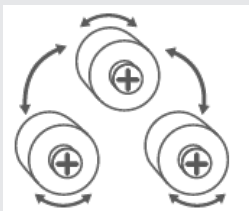

PIC: ROLLER  
MOVEMENT E-PW 40 H

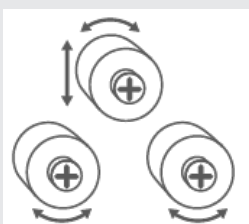

PIC: ROLLER MOVEMENT  
E-PW 50 H / E-PW 60 H

Description	E-PW 40 H	E-PW 50 H	E-PW 60 H
axis diameter	40 mm	50 mm	60 mm
upper rolls - diameter	137 mm	152 mm	215 mm
lower rolls - diameter	137 mm	162 mm	215 mm
horizontal working	yes	yes	yes
speed	7 m/min	4,5 m/min	4 m/min
hydraulic power		8 t	16 t
motor power	400 V / 50 Hz / 1,1 kW	400 V / 50 Hz / 1,1 kW	400 V / 50 Hz / 1,5 kW
dimensions (W x D x H)	1.050 x 530 x 1.250 mm	810 x 950 x 1.500 mm	1.000 x 1.400 x 1.650 mm
weight	350 kg	500 kg	950 kg
	<b>E-PW 40 H</b>	<b>E-PW 50 H</b>	<b>E-PW 60 H</b>
<b>EAN</b>	<b>4260364298420</b>	<b>4260364292282</b>	<b>4260364292299</b>
<b>Item No.</b>	<b>351 0040</b>	<b>351 0050</b>	<b>351 0060</b>

DRILLING

MILLING

TURNING

SAWING

GRINDING

BENDING

CUTTING /  
PRESSING

OTHER  
MACHINES

ACCESSORIES

# E-PW 70 H

## HYDRAULIC PROFILE ROLLER MACHINE

**PREMIUM-LINE**

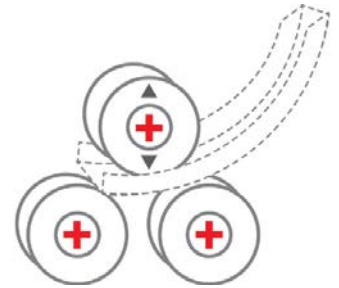

### E-PW 70 H WITH FOOT CONTROL

A machine with a special arrangement of the bottom rollers. These can be moved horizontally. Due to the variable position of the lower rollers, 180-degree bends can also be inserted into long strips or pipes, e.g. cooling pipes, with little effort. The top roll can be used to calibrate and reroll previously bent parts just like a conventional workshop press.

- » welded steel construction frame
- » 3 driven rollers
- » top roller with hydraulic feed
- » bottom rollers horizontally adjustable
- » hardened and grounded shafts made of high strength special steel
- » horizontal and vertical operation (machine can be folded down)
- » mobile control panel
- » adjustable lateral guide rollers

Special accessories:  
Rollers for tubes and profiles,  
NC-control

Description	E-PW 70 H
upper axis diameter	60 mm
lower axis diameter	50 mm
roller diameter	180 mm
horizontal working	yes
speed	5 m/min
motor power	400 V / 50 Hz / 3 kW
dimensions (W x D x H)	850 x 1.200 x 1.200 mm
weight	1.000 kg
E-PW 70 H	
<b>EAN</b>	<b>4260364297805</b>
<b>Item No.</b>	<b>351 0070</b>



# E-PW 65 H / E-PW 80 H

## HYDRAULIC PROFILE ROLLER MACHINES

**PREMIUM-LINE**



PIC: E-PW 65 H



PIC: E-PW 80 H

### E-PW 65 H / E-PW 80 H

- » steel welded frame construction
- » 3 driven rolls
- » 2-level digital display (lower rolls)
- » hardened and ground shaft made of high tensile special steel
- » horizontal and vertical bending (machine inclinable)

- » hardened roller sets as standard
- » mobile control panel
- » brake motor equipped
- » side leveling rollers, adjustable for spiral bending

Description	E-PW 65 H	E-PW 80 H
upper axis diameter	60 mm	80 mm
lower axis diameter	50 mm	70 mm
roller diameter	180 mm	245 mm
horizontal working	yes	yes
speed	5 m/min	6 m/min
motor power	400 V / 50 Hz / 3 kW	400 V / 50 Hz / 4 kW
dimensions (W x D x H)	850 x 1.200 x 1.200 mm	1.000 x 1.450 x 1.400 mm
weight	1.000 kg	1.700 kg
	<b>E-PW 65 H</b>	<b>E-PW 80 H</b>
<b>EAN</b>	<b>4260364292305</b>	<b>4260364292312</b>
<b>Item No.</b>	<b>351 0065</b>	<b>351 0080</b>

DRILLING

MILLING

TURNING

SAWING

GRINDING

BENDING

CUTTING / PRESSING

OTHER MACHINES

ACCESSORIES

## E-PW 100 H / E-PW 120 H HYDRAULIC PROFILE ROLLER MACHINES

**PREMIUM-LINE**



PIC: E-PW 100 H



PIC: E-PW 120 H

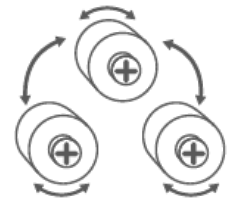

### E-PW 100 H / E-PW 120 H

- » steel welded frame construction
- » 3 driven rolls
- » 2-level digital display (lower rolls)
- » hardened and ground shafts made of high tensile special steel
- » horizontal and vertical bending (machine inclinable)
- » hardened roller sets as standard
- » mobile control panel
- » stepless adjustable lateral rolls for spiral bending

Description	E-PW 100 H	E-PW 120 H
upper axis diameter	100 mm	120 mm
lower axis diameter	-	-
roller diameter	315 mm	390 mm
horizontal working	yes	yes
speed	7 m/min	2 - 7,5 m/min
motor power	400 V / 50 Hz / 7,5 kW	400 V / 50 Hz / 15 kW
dimensions (W x D x H)	1.450 x 2.000 x 1.700 mm	1.650 x 2.000 x 1.900 mm
weight	3.650 kg	4.770 kg
	<b>E-PW 100 H</b>	<b>E-PW 120 H</b>
<b>EAN</b>	<b>4260364292329</b>	<b>4260364294491</b>
<b>Item No.</b>	<b>351 0100</b>	<b>351 0120</b>

### OPTIONAL ACCESSORIES

- » tube and profile roller kits
- » 3-axis hydraulic lateral guide rolls
- » stepless driving speed adjustment

# E-PW 160 H / E-PW 180 H

## HYDRAULIC PROFILE ROLLER MACHINES

**PREMIUM-LINE**



PIC: E-PW 180 H

### E-PW 160 H / E-PW 180 H

- » steel welded frame construction
- » 3 driven rolls
- » 2-level digital display (lower rolls)
- » horizontal and vertical bending (machine inclinable)
- » hardened roller sets as standard
- » mobile control panel
- » brake motor equipped
- » stepless adjustable lateral rolls for spiral bending

### OPTIONAL ACCESSORIES

- » tube and profile roller kits
- » stepless driving speed adjustment

Description	E-PW 160 H	E-PW 180 H
upper axis diameter	160 mm	180 mm
lower axis diameter	160 mm	180 mm
roller diameter	500 mm	580 mm
horizontal working	yes	yes
speed	3 - 6 m/min	3 - 6 m/min
motor power	400 V / 50 Hz / 22 kW	400 V / 50 Hz / 30 kW
dimensions (W x D x H)	2.350 x 2.500 x 2.600 mm	2.400 x 2.600 x 3.000 mm
weight	10.700 kg	12.000 kg
	E-PW 160 H	E-PW 180 H
<b>EAN</b>	<b>4260364294507</b>	<b>4260364298444</b>
<b>Item No.</b>	<b>351 0160</b>	<b>351 0180</b>

DRILLING

MILLING

TURNING

SAWING

GRINDING

BENDING

CUTTING /  
PRESSING

OTHER  
MACHINES

ACCESSORIES

**E-PW 200 H**  
HYDRAULIC PROFILE ROLLER MACHINES

**PREMIUM-LINE**



PIC: E-PW 200 H

**E-PW 200 H**

- » steel welded frame construction
- » 3 driven rolls
- » 2-level digital display (lower rolls)
- » hardened and ground shafts made of high tensile special steel
- » hardened roller sets as standard
- » mobile control panel
- » stepless adjustable lateral rolls for spiral bending

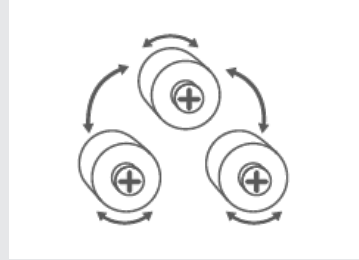

Description	E-PW 200 H
upper axis diameter	200 mm
roller diameter	650 mm
horizontal working	yes
speed	2 - 5 m/min
motor power	400 V / 50 Hz / 30 kW
dimensions (L x D x H)	3.400 x 2.400 x 2.300 mm
weight	15.000 kg
<b>E-PW 200 H</b>	
<b>EAN</b>	<b>4260364294514</b>
<b>Item No.</b>	<b>351 0200</b>

**OPTIONAL ACCESSORIES**

- » tube and profile roller kits
- » stepless driving speed adjustment

# E-PW 240 H / E-PW 360 H

## HYDRAULIC PROFILE ROLLER MACHINES

**PREMIUM-LINE**



PIC: E-PW 240 H

### E-PW 240 H / E-PW 360 H

- » steel welded frame construction
- » 3 hydraulically driven rolls by planetary gear
- » 2-level digital display (lower rolls)
- » hardened roller sets as standard
- » hardened and ground shafts
- » mobile control panel
- » standard castor set on request

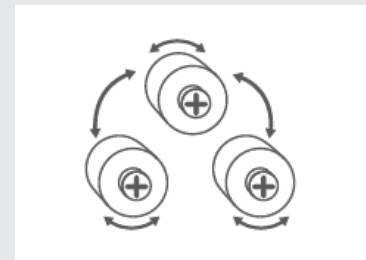

### OPTIONAL ACCESSORIES

- » tube and profile roller kits
- » stepless driving speed adjustment

Description	E-PW 240 H	E-PW 360 H
upper axis diameter	240 mm	360 mm
roller diameter	620 mm	800 mm
speed	2 - 4 m/min	2 - 4 m/min
motor power	400 V / 50 Hz / 44 kW	400 V / 50 Hz / 77 kW
dimensions (L x D x H)	3.100 x 2.400 x 3.200 mm	5.000 x 4.250 x 3.750 mm
weight	19.800 kg	55.000 kg
	<b>E-PW 240 H</b>	<b>E-PW 360 H</b>
<b>EAN</b>	<b>4260364296648</b>	<b>4260364296655</b>
<b>Item No.</b>	<b>351 1240</b>	<b>351 1360</b>

More sizes are available on request.

DRILLING

MILLING

TURNING

SAWING

GRINDING

BENDING

CUTTING /  
PRESSING

OTHER  
MACHINES









ACCESSORIES









# E-PW 35 F / E-PW 40 H / E-PW 50 H

## ROLLER SETS

### STANDARD ROLLER SETS

Profile	E-PW 35 F Dimensions	E-PW 35 F min ø in mm	E-PW 40 H Dimensions	E-PW 40 H min ø in mm	E-PW 50 H Dimensions	E-PW 50 H min ø in mm
	60 x 10 40 x 10	500 400	35 x 8	300	60 x 10 20 x 10	600 300
	100 x 15 60 x 10	450 350	50 x 12	400	100 x 15 50 x 10	600 300
	35 x 35 20 x 20	900 300	18 x 18	250	35 x 35 15 x 15	600 300
	60 x 7 50 x 6	700 500	30 x 30 x 5	300	60 x 7 30 x 4	800 500
	60 x 7 50 x 6	700 500	35 x 35 x 5	350	50 x 6 30 x 4	800 500
	60 x 7 50 x 6	700 500	35 x 35 x 5	300	60 x 7 30 x 4	800 500
	UPN 80 UPN 60	1.000 700	UPN 40 x 20	350	UPN 80 UPN 30	800 400
	UPN 80 UPN 30	1.200 800	UPN 35 x 18	500	UPN 80 UPN 30	1.200 600

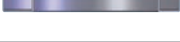
### OPTIONAL ROLLER SETS MADE OF STEEL

Profile	E-PW 35 F Dimensions	E-PW 35 F min ø in mm	E-PW 40 H Dimensions	E-PW 40 H min ø in mm	E-PW 50 H Dimensions	E-PW 50 H min ø in mm
	ø 35 ø 30	600 400	ø 22	200	ø 35 ø 20	600 300
	ø 70 x 2 ø 30 x 2	1.000 500	ø 40 x 1,5	500	ø 70 x 2 ø 25 x 1,5	1.200 400
	2" x 2,9 1" x 2,3	1.000 350	ø 1 1/2" x 2,3	200	2" x 2,9 1/2" x 2,3	1.000 300
	70 x 30 x 2 50 x 40 x 3	1.200 1.200	30 x 15 x 2,5	500	70 x 30 x 3 30 x 15 x 2	1.500 400
	50 x 3 40 x 3	1.700 600	25 x 25 x 2	450	50 x 3 20 x 2	1.600 400
	50 x 50 x 5 40 x 40 x 5	1.000 600	35 x 35 x 5	400	50 x 50 x 6 30 x 30 x 3	600 400
	50 x 50 x 6 30 x 30 x 3	1.000 500	30 x 30 x 4	550	50 x 50 x 6 30 x 30 x 3	900 600

PLASTIC ROLLS FOR BENDING STAINLESS STEEL ARE AVAILABLE ON REQUEST.

# E-PW 60 H / E-PW 65 H / E-PW 70 H ROLLER SETS

## STANDARD ROLLER SETS

Profile	E-PW 60 H Dimensions	E-PW 60 H min ø in mm	E-PW 65 H Dimensions	E-PW 65 H min ø in mm	E-PW 70 H Dimensions	E-PW 70 H min ø in mm
	80 x 20 40 x 10	1.200 400	60 x 10 20 x 5	500 250	60 x 10 20 x 5	500 250
	120 x 25 50 x 10	600 400	80 x 20 50 x 5	500 250	80 x 20 50 x 5	500 250
	50 x 50 20 x 20	800 400	32 x 32 12 x 12	400 250	32 x 32 12 x 12	400 250
	80 x 9 40 x 5	1.000 400	60 x 7 20 x 3	550 250	60 x 7 20 x 3	550 250
	80 x 9 40 x 5	1.200 500	50 x 6 20 x 3	500 250	50 x 6 20 x 3	500 250
	80 x 9 40 x 5	1.000 400	60 x 70 20 x 3	500 250	60 x 70 20 x 3	500 250
	UPN 120 UPN 60	800 500	UPN 80 UPN 30	600 250	UPN 80 UPN 30	600 250
	UPN 120 UPN 60	1.200 600	UPN 65 UPN 30	600 250	UPN 65 UPN 30	600 250

## OPTIONAL ROLLER SETS MADE OF STEEL

Profile	E-PW 60 H Dimensions	E-PW 60 H min ø in mm	E-PW 65 H Dimensions	E-PW 65 H min ø in mm	E-PW 70 H Dimensions	E-PW 70 H min ø in mm
	ø 50 ø 20	800 400	ø 35 ø 10	350 250	ø 35 ø 10	350 250
	ø 100 x 2 ø 60 x 2	1.600 500	ø 60 x 2 ø 15 x 1,5	600 200	ø 60 x 2 ø 15 x 1,5	600 200
	3" x 3,2 1" x 2,6	1.600 500	2" x 3,91 1/2" x 2,77	400 200	2" x 3,91 1/2" x 2,77	400 200
	80 x 40 x 3 40 x 20 x 2	1.400 500	50 x 25 x 3 20 x 15 x 2	450 250	50 x 25 x 3 20 x 15 x 2	450 250
	70 x 3 40 x 2	1.600 500	45 x 3 20 x 2	600 300	45 x 3 20 x 2	600 300
	70 x 70 x 7 40 x 40 x 5	1.000 500	60 x 60 x 6 30 x 30 x 4	650 350	60 x 60 x 6 30 x 30 x 4	650 350
	70 x 70 x 7 40 x 40 x 5	1.200 600	50 x 50 x 5 30 x 30 x 4	550 350	50 x 50 x 5 30 x 30 x 4	550 350

PLASTIC ROLLS FOR BENDING STAINLESS STEEL ARE AVAILABLE ON REQUEST.

# E-PW 80 H / E-PW 100 H / E-PW 120 H

## ROLLER SETS

### STANDARD ROLLER SETS

Profile	E-PW 80 H Dimensions	E-PW 80 H min ø in mm	E-PW 100 H Dimensions	E-PW 100 H min ø in mm	E-PW 120 H Dimensions	E-PW 120 H min ø in mm
	100 x 20 80 x 20 30 x 10	2.000 800 300	100 x 20 30 x 10	800 400	125 x 25 30 x 10	1.200 500
	125 x 25 60 x 5	600 300	200 x 30 160 x 35 80 x 5	1.200 800 400	200 x 50 100 x 10	1.000 500
	45 x 45 15 x 15	500 380	60 x 60 15 x 15	750 400	65 x 65 20 x 20	750 500
	80 x 9 25 x 3,5	800 450	90 x 10 30 x 4	1.000 400	100 x 11 30 x 4	800 500
	70 x 8 23 x 3,5	800 280	90 x 10 30 x 4	1.000 400	100 x 11 30 x 4	1.000 500
	80 x 9 30 x 4	800 300	100 x 11 30 x 4	1.000 400	---	---
	UPN 140 UPN 120 UPN 100	1.600 900 800	UPN 180 UPN 30	900 400	UPN 220 UPN 180 UPN 40	1.000 800 500
	UPN 140 UPN 120 UPN 100	1.600 1.000 800	UPN 180 UPN 30	1.000 400	UPN 220 UPN 180 UPN 40	1.200 900 600







### STEEL ROLLER SETS OPTIONAL

Profile	E-PW 80 H Dimensions	E-PW 80 H min ø in mm	E-PW 100 H Dimensions	E-PW 100 H min ø in mm	E-PW 120 H Dimensions	E-PW 120 H min ø in mm
	ø 50 ø 15	500 380	ø 75 ø 15	800 450	ø 80 ø 20	850 500
	ø 100 x 2,5 ø 15 x 1	1.200 380	ø 125 x 2,5 ø 15 x 1	1.400 450	ø 160 x 4 ø 140 x 3 ø 50 x 2	2.800 1.500 500
	3" x 5,48 1/2" x 2,77	800 380	4" x 4,5 1/2" x 2,77	2.500 450	5" x 6,35 3/4" x 2,87	1.500 500
	80 x 25 x 3 25 x 15 x 2	800 350	100 x 40 x 4 25 x 15 x 2	1.300 450	120 x 40 x 4 30 x 20 x 3	1.800 500
	70 x 3 25 x 2	1.300 350	80 x 5 25 x 2	1.500 450	90 x 5 30 x 3	1.800 500
	80 x 80 x 8 30 x 30 x 3	800 400	100 x 100 x 12 40 x 40 x 4	1.000 700	120 x 120 x 12 40 x 40 x 4	1.200 600
	70 x 70 x 7 30 x 30 x 3	700 450	100 x 100 x 10 40 x 40 x 4	1.500 550	100 x 100 x 10 40 x 40 x 4	1.200 600







For all machines of the E-PW series special rollers can be manufactured optionally.

# E-PW 160 H / E-PW 200 H / E-PW 240 H ROLLER SETS

## STANDARD ROLLER SETS

Profile	E-PW 160 H Dimensions	E-PW 160 H min ø in mm	E-PW 180 H Dimensions	E-PW 180 H min ø in mm	E-PW 200 H Dimensions	E-PW 200 H min ø in mm
	150 x 40 50 x 10	2.500 700	180 x 30	2.500	200 x 50	3.500
	280 x 50 120 x 15	1.500 700	280 x 60	2.000	350 x 80	2.500
	90 x 90 30 x 30	1.500 700	110 x 110	2.000	120 x 120	3.000
	150 x 15	2.000	160 x 20	2.500	200 x 20	3.500
	150 x 15	2.000	150 x 20	3.000	200 x 20	3.500
	UPN 300	2.000	UPN 350	2.500	UPN 380	3.000
	UPN 300	2.500	UPN 350	3.000	UPN 300	2.500

## STEEL ROLLER SETS OPTIONAL

Profile	E-PW 160 H Dimensions	E-PW 160 H min ø in mm	E-PW 180 H Dimensions	E-PW 180 H min ø in mm	E-PW 200 H Dimensions	E-PW 200 H min ø in mm
	ø 90	1.800	ø 110	2.000	ø 120	3.000
	ø 150 x 4	6.000	ø 220 x 4	8.000	ø 273 x 5,6	10.000
	6" x 7,11	3.500	8" x 8,18	4.000	9" x 6,3	4.000
	150 x 50 x 5	4.500	200 x 100 x 8	5.000	220 x 80 x 7	7.000
	120 x 6	4.000	150 x 8	4.500	180 x 10	5.500
	150 x 150 x 18	4.000	180 x 180 x 18	2x500	200 x 200 x 20	3.000
	140 x 140 x 14	5.000	180 x 180 x 15	4.000	180 x 180 x 18	4.000

For all machines of the E-PW series special rollers can be manufactured optionally.

DRILLING

MILLING

TURNING

SAWING

GRINDING

BENDING

CUTTING /  
PRESSING

OTHER  
MACHINES

ACCESSORIES

# E-4PW 70 H

## HYDRAULIC PROFILE ROLLER MACHINE

**NEW**

**PREMIUM-LINE**



Description	E-4PW 70 H
axis diameter	70 mm
roller diameter	200 mm
horizontal working	yes
speed	8 m/min
motor power	400 V / 50 Hz / 3 kW
dimensions (L x D x H)	1.200 x 1.100 x 800 mm
weight	1.400 kg
	E-4PW 70 H
<b>EAN</b>	<b>4260364296662</b>
<b>Item No.</b>	<b>351 2070</b>

### E-4PW 70 H

- » machine frame as stable welded construction
- » up and down movement of base and side rollers hydraulically
- » two driven rollers
- » guide made of high-strength and hardened steel, also inside the housing
- » operation via mobile panel
- » machine can be used vertically and horizontally

### OPTIONAL ACCESSORIES

- » drive for 3rd roller



# E-4 PW 90 H / E-4 PW 110 H

## HYDRAULIC PROFILE ROLLER MACHINES

NEW

PREMIUM-LINE

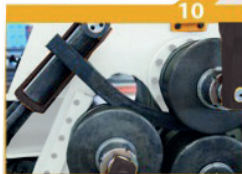

### E-4PW 90 H / E-4PW 110 H

- » 4-roll profile bending machines with direct drive by means of hydraulic motor and planetary gear for top and side shafts.
- » hydraulic positioning of the bottom and side rollers
- » drive shafts made of high-strength steel, hardened
- » mobile control panel with 3 digital displays (bottom roller and side rollers)



Description	E-4PW 90 H	E-4PW 110 H
axis diameter	90 mm	110 mm
roller diameter	260 mm	320 mm
horizontal working	yes	yes
speed	6,37 m/min	4,98 m/min
motor power	400 V / 50 Hz / 5,5 kW	400 V / 50 Hz / 7,5 kW
dimensions (L x D x H)	1.700 x 1.450 x 1.200 mm	2.000 x 1.700 x 1.250 mm
weight	2.800 kg	4.500 kg
	<b>E-4PW 90 H</b>	<b>E-4PW 110 H</b>
<b>EAN</b>	<b>4260364296679</b>	<b>4260364296686</b>
<b>Item No.</b>	<b>351 2090</b>	<b>351 2110</b>

DRILLING

MILLING

TURNING

SAWING

GRINDING

BENDING

CUTTING / PRESSING











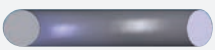
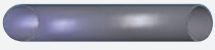
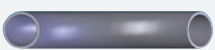

OTHER MACHINES

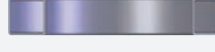
ACCESSORIES

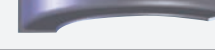
# E-4PW 70 H / E-4PW 90 H / E-4PW 110 H

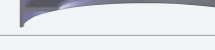
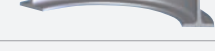
## ROLLER SETS

### Roller Sets

Profil Typ	E-4PW 70 H		E-4PW 90 H		E-4PW 110 H		
	Size	Min Ø	Size	Min Ø	Size	Min Ø	
	60 x 10	500	100 x 20	2.000	100 x 20	800	Standard
	20 x 5	250	80 x 20 30 x 10	800 300	30 x 10	400	
	80 x 20	500	125 x 25	600	200 x 30	1.200	Standard
	50 x 5	250	60 x 5	300	160 x 35 80 x 5	800 400	
	32 x 32	400	45 x 45	500	60 x 60	750	Standard
	12 x 12	250	15 x 15	380	15 x 15	400	
	Ø 35	350	Ø 50	500	Ø 75	800	Optional
	Ø 10	250	Ø 15	380	Ø 15	450	
	Ø 60 x 2	600	Ø 100 x 2,5	1.200	Ø 120 x 2,5	1.400	Optional
	Ø 15 x 1,5	200	Ø 15 x 1	380	Ø 15 x 1	450	
	Ø 2" x 3,91	400	Ø 3" x 5,48	800	Ø 4" x 6,02	1.000	Optional
	Ø 1/2" x 2,77	200	Ø 1/2" x 2,77	380	Ø 1/2" x 2,77	450	
	50 x 25 x 3	450	80 x 25 x 3	800	100 x 40 x 4	1.300	Optional
	20 x 15 x 2	250	25 x 15 x 2	350	25 x 15 x 2	450	
	45 x 3	600	70 x 3	1.300	80 x 5	1.500	Optional
	20 x 2	300	25 x 2	400	25 x 2	450	
	60 x 60 x 6	650	80 x 80 x 8	800	100 x 100 x 12	1.000	Optional
	30 x 30 x 4	350	30 x 30 x 3	450	40 x 40 x 4	700	
	50 x 50 x 5	550	70 x 70 x 7	700	100 x 100 x 10	1.000	Optional
	30 x 30 x 4	350	30 x 30 x 3	460	40 x 40 x 4	550	
	60 x 7	550	80 x 9	800	100 x 11	1.000	Standard
	20 x 3	250	25 x 3,5	280	30 x 4	400	
	50 x 6	500	70 x 8	800	90 x 10	1.000	Standard
	20 x 3	250	25 x 3,5	280	30 x 4	400	
	60 x 70	500	80 x 9	800	100 x 11	1.000	Optional
	20 x 3	250	30 x 4	300	30 x 4	400	
	UPN 80	600	UPN 140	1.600	UPN 180	900	Standard
	UPN 30	250	UPN 120 UPN 100	900 600	UPN 30	400	
	UPN 65	600	UPN 140	1.600	UPN 180	1.000	Standard
	UPN 30	250	UPN 120 UPN 100	1.000 800	UPN 30	400	
	IPN 80	600	IPN 120	600	IPN 180	1.000	Optional
			IPN 80	400	IPN 80	400	

PLASTIC ROLLS FOR BENDING STAINLESS STEEL ARE AVAILABLE ON REQUEST.

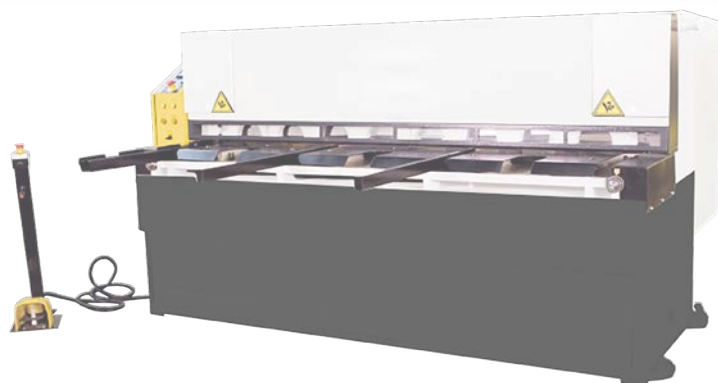
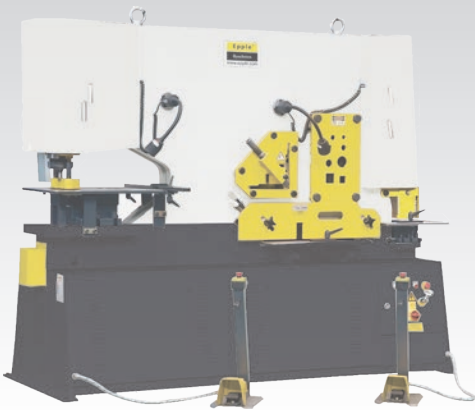

# Cutting Machines

## EK 1 / EK 2 / EK 3 / EK 8-E

### NOTCHING MACHINES FOR PIPES



PIC: EK 2

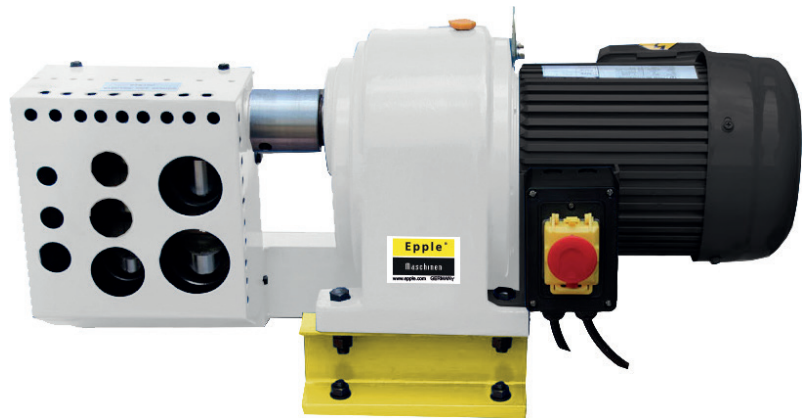

PIC: EK 8-E

#### EK 1 / EK 2 / EK 3 / EK 8-E FOR DIFFERENT DIAMETERS

- » from mild steel to high grade steel and other pipes to 3 mm wall thickness
- » different rolls dia in one unit
- » high productiveness with low investment
- » clear edges, so there is no rework necessary
- » low force required due to eccentric shaft (**EK 1 - 3**)
- » motorized notching cut (just incl. in model EK 8-E)

#### EXAMPLE OF USE

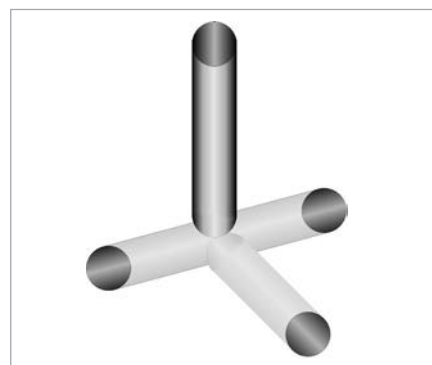

Description	EK 1	EK 2	EK 3	EK 8-E
outer diameter of the tube	1/4", 3/8", 1/2"	3/4", 1", 1-1/4"	1-1/2", 2"	1/4" bis 2"
max. wall thickness	3 mm	3 mm	3 mm	3 mm
weight	6 kg	8 kg	15 kg	98 kg
	EK 1	EK 2	EK 3	EK 8-E
EAN	4260364292367	4260364292374	4260364292381	4260364297362
Item No.	225 1001	225 1002	225 1003	325 1008

# AM 4T / AM 4T-3,0 / AM 4PT / HAM-P 3,0 MANUAL NOTCHING MACHINE



PIC: AM 4T



PIC: AM 4PT



PIC: HAM-P 3,0

## AM 4T / AM 4T-3,0 / AM 4PT / HAM-P 3,0

- » solid punching machine with high pressure
- » free of burrs cut by precision cutting edge from high - quality steel
- » universally adjustable stop for the serial production
- » for cutting of corners, forms etc.
- » body is of steel construction
- » no deflection of the cutting edge is possible

Model AM 4 PT (floor model) without hand lever, operation via foot pedal

Model HAM-P 3,0 (floor model) with pneumatic drive (up to 8 bar)

Description	AM 4T	AM 4T - 3,0	AM 4PT	HAM-P 3,0
max. sheet thickness	1,5 mm	3,0 mm	1,5 mm	3,0 mm
max. stamp length	152 x 152 mm	100 x 100 mm	80 x 80 mm	130 x 130 mm
cutting angle	90°	90°	90°	90°
cutting pressure	20 mm	30 mm	25 mm	28 - 30 mm
table size	460 x 310 mm	450 x 300 mm	310 x 310 mm	600 x 460 mm
dimensions (L x D x H)	530 x 520 x 580 mm	460 x 450 x 760 mm	510 x 400 x 1.150 mm	600 x 680 x 1.255 mm
weight	75 kg	105 kg	74 kg	188 kg
	<b>AM 4T</b>	<b>AM 4T - 3,0</b>	<b>AM 4PT</b>	<b>HAM-P 3,0</b>
EAN	4260364292398	4260364299540	4260364298451	4260657651758
Item No.	225 1040	225 3040	225 2040	225 2030



# E-HAM 4 F / E-HAM 6 VP

## HYDRAULIC NOTCHING MACHINES

**PREMIUM-LINE**



PIC: E-HAM 6 VP

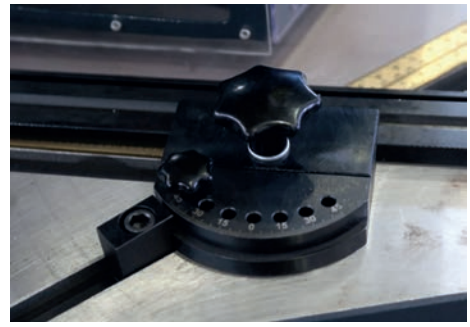

REAR HOLE PUNCHING UNIT ONLY FOR MODEL E-HAM 6 VP

OPTIONAL

» rear hole punching unit

EXAMPLE OF USE

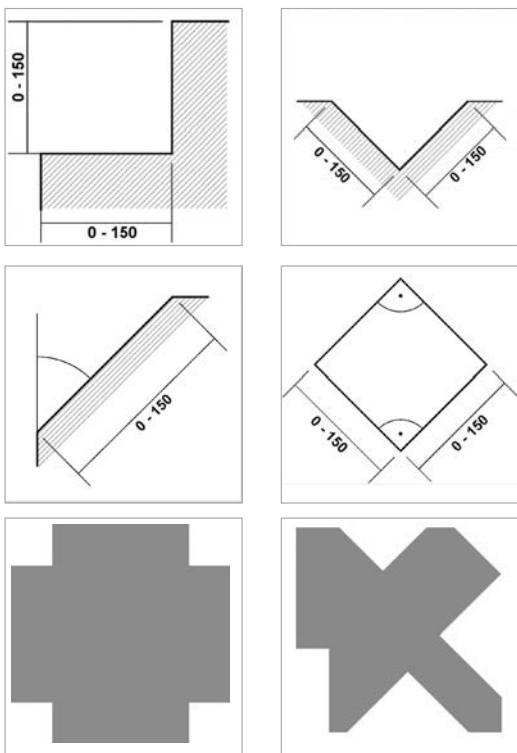

Description	E-HAM 4 F	E-HAM 6 VP
sheet thickness - ST 37	4 mm (90°)	6 mm (60 - 140°) 4 mm (30 - 59°)
sheet thickness - stainless steel	2,5 mm (90°)	3 mm (60 - 140°) 2,5 mm (30 - 59°)
table size	685 x 590 mm	1.150 x 610 mm
cutting angle	90°	30 - 140°
max. cutting operations	50 per min.	30 per min.
max. punching length	197 x 197 mm	200 x 200 mm
oil tank	45 Liter	35 Liter
cutting pressure	120 bar	200 bar
motor power	4 kW	4 kW
dimensions (L x D x H)	1.120 x 1.200 x 1.600 mm	1.150 x 1.160 x 1.440 mm
weight	500 kg	1.050 kg
	<b>E-HAM 4 F</b>	<b>E-HAM 6 VP</b>
<b>EAN</b>	<b>4260364298819</b>	<b>4260364296693</b>
<b>Item No.</b>	<b>353 1004</b>	<b>353 1006</b>

# E-KS 1,8 M

## CIRCULAR SHEAR

PREMIUM-LINE



### E-KS 1,8 M

Electric circular shears for cutting various materials.

- » workpiece clamping and measuring setting manually
- » extremely stable and robust welded construction
- » knives made of special steel K2379, bronze bearing
- » knives are hardened, adjustable and regrindable
- » geared motor with brake system
- » central lubrication
- » very good value of money

### OPTIONAL ACCESSORIES

- » pneumatic clutch system

Description	E-KS 1,8 M
sheet thickness (St 42)	max. 2,0 mm
min. workpiece diameter	100 mm
max. workpiece diameter	1.000 mm
cutting speed	7,5 m/min
motor power	1,1 kW
working range	700 mm
hump depth	280 mm
dimensions (L x D x H)	1.350 x 400 x 1.300 mm
weight	220 kg
	<b>E-KS 1,8 M</b>
<b>EAN</b>	<b>4260364296709</b>
<b>Item No.</b>	<b>353 1018</b>

# E-KS 3,5 M / E-KS 5 M CIRCULAR SHEARS

**PREMIUM-LINE**



PIC: E-KS 3,5 M

## E-KS 3,5 M / E-KS 5 M

Electric circular shears for cutting various materials.

- » workpiece clamping hydraulically, measuring setting manual (E-KS 3,5 M)
- » workpiece clamping and hydraulic adjustment (E-KS 5 M)
- » extremely stable and robust welded construction
- » knives made of special steel K2379, bronze bearing
- » knives are hardened, adjustable and regrindable
- » geared motor with brake system
- » central lubrication
- » hydraulic driven sheet centering system
- » very good value of money

Description	E-KS 3,5 M	E-KS 5 M
sheet thickness (St 37)	max. 3,5 mm	max. 5,0 mm
min. workpiece diameter	200 mm	250 mm
max. workpiece diameter	1.200 mm	2.000 mm
cutting speed	6,1 m/min	4,1 m/min
motor power	400 V / 50 Hz / 2,2 kW	400 V / 50 Hz / 2,2 kW
working range	750 mm	880 mm
hump depth	250 mm	300 mm
dimensions (L x D x H)	2.000 x 600 x 1.400 mm	3.000 x 750 x 1.400 mm
weight	750 kg	1.350 kg
	<b>E-KS 3,5 M</b>	<b>E-KS 5 M</b>
<b>EAN</b>	<b>4260364294521</b>	<b>4260364294538</b>
<b>Item No.</b>	<b>353 1035</b>	<b>353 1050</b>

# HS 125 / HS 150 / HS 300

## HAND LEVER SHEARS



PIC: HS 125

PIC: HS 300

### HS 125 / HS 150 / HS 300

- » for cutting of sheets and sheet profiles
- » in the top knife stands an admission bore for sectioning of round material
- » across the complete cut length
- » power gentle and easy separating
- » the workpart is positioned by an adjustable hold down clamp
- » shear is assured by a strong spring against independent closing
- » solid hand grip assures a safe operation
- » ergonomic cutting geometry
- » fixed cutters
- » robust shear body
- » stable pedestal with fixing bores

Description	HS 125	HS 150	HS 300
round material	Ø 11 mm	Ø 11 mm	Ø 13 mm
material length	127 mm	152 mm	304 mm
material thickness	6 mm	6 mm	6 mm
weight	9 kg	10 kg	26 kg
	HS 125	HS 150	HS 300
<b>EAN</b>	4260364292404	4260364292411	4260364292428
<b>Item No.</b>	226 0125	226 0150	226 0300

Description	spare plate for HS 125	spare plate for HS 150	spare plate for HS 300
<b>EAN</b>	4260364292435	4260364292442	4260364292459
<b>Item No.</b>	547 0125	547 0150	547 0300

# TFS 1.050-1,0

## LEVER SHEARS



Lever Shear

### TFS 1.050-1,0

UNIVERSAL SHEAR FOR METAL,  
PAPER AND OTHER MATERIALS

- » heavy duty cast iron construction
- » retraction of blade over spring
- » with manual holding down clamp for perfect achievement
- » large work table
- » centre console
- » adjustable parallel limit stop by hand crank
- » very good price performance ratio

- » cutting performance data refer to 24 kg/m<sup>2</sup> sheet bending limit
- » sheet thickness for stainless steel: factor 0,5
- » sheet thickness for aluminum: factor 1,2

Description	TFS 1.050-1,0
sheet thickness	max. 1 mm
working width	1.000 mm
dimensions (L x D x H)	1.500 x 1.275 x 1.500 mm
weight	240 kg
<b>TFS 1.050-1,0</b>	
<b>EAN</b>	<b>4260364292473</b>
<b>Item No.</b>	<b>225 0715</b>



# E-TFS 1.050-1,5 / E-TFS 1.350-1,5

## LEVER SHEARS

**PREMIUM-LINE**



PIC: E-TFS 1.050-1,5

Heavy cast design, no welded construction.

### E-TFS 1.050-1,5 / E-TFS 1.350-1,5

UNIVERSAL SHEAR FOR  
SHEETS AND OTHER  
MATERIALS

- » ideal for industry and craftsmen
- » high quality converting
- » for steel discs up to 1,5 mm
- » with variable holding down clamp for a perfect achievement
- » large working table
- » heavy cast iron construction, no welded construction

- » cutting performance data refer to 24 kg/m<sup>2</sup> sheet bending limit
- » sheet thickness for stainless steel: factor 0,5
- » sheet thickness for aluminum: factor 1,2

Description	E-TFS 1.050-1,5	E-TFS 1.350-1,5
Blade length	1.050 mm	1.350 mm
sheet thickness	max. 1,5 mm	max. 1,5 mm
working width	1.000 mm	1.300 mm
table size	600 x 1.270 mm	600 x 1.570 mm
dimensions (L x D x H)	1.980 x 840 x 1.160 mm	2.280 x 840 x 1.160 mm
weight	420 kg	510 kg
	<b>E-TFS 1.050-1,5</b>	<b>E-TFS 1.350-1,5</b>
EAN	4260364297218	4260364297225
Item No.	353 1051	353 1350

DRILLING

MILLING

TURNING

SAWING

GRINDING

BENDING

CUTTING /  
PRESSING

OTHER  
MACHINES

ACCESSORIES

## E-MTSK-MODELS

MOTORIC GUILLOTINE SHEAR WITH CUTTING EMISSION  
REAR OR FRONT

PREMIUM-LINE



PIC: E -MTSK 3.060-4,0 WITH  
OPTIONAL TOUCHSCREEN CONTROL

### E-MTSK-MODELS

Ideal when space is limited or when mainly small parts are cut.

- » support table with ball rollers, T-slots and lateral stop with scale
- » automatic hold-down-device for fixing sheet metal
- » cut-line lightning with silhouette
- » cutting gap adjustment in the front
- » cutting knife made of tool steel with two cutting edges
- » backgauge with recirculating ballscrews
- » pneumatic sheet holding device
- » sheet metal ejection optionally at the front or rear of the machine
- » mobile foot pedal and emergency stop button

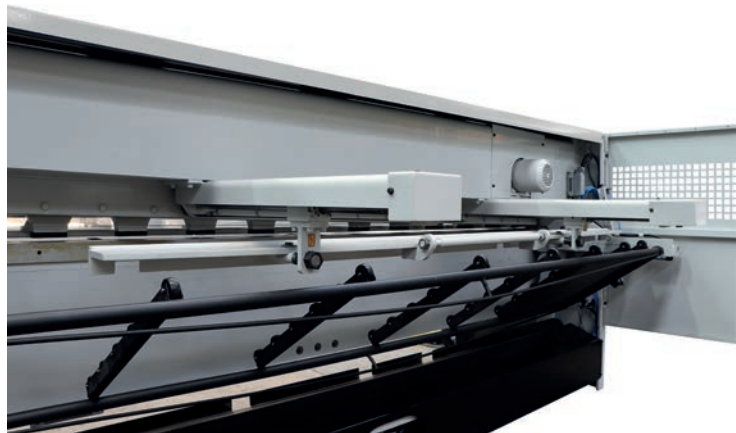

PIC: E -MTSK 3.060-4,0 REAR VIEW  
(SHEET EJECTION FORWARD)



PIC: E -MTSK 3.060-4,0 REAR VIEW  
(SHEET EJECTION TO THE REAR)

- » bending performance data refer to 24 kg/m<sup>2</sup> sheet bending limit
- » sheet thickness for stainless steel: factor 0,5
- » sheet thickness for aluminum: factor 1,2

Description	E-MTSK 1.100-6,0	E-MTSK 1.560-5,0	E-MTSK 2.060-4,0	E-MTSK 2.560-4,0	E-MTSK 3.060-4,0
working length	1.100 mm	1.560 mm	2.060 mm	2.560 mm	3.060 mm
max. thickness	6 mm	5 mm	4 mm	4 mm	4 mm
cutting angle	2°	2°	1°30'	1°30'	1°30'
strokes per minute	31	31	31	31	31
table height	800 mm	800 mm	830 mm	800 mm	830 mm
backgauge	0-750 mm	0-750 mm	0-750 mm	0-750 mm	0-750 mm
working width	455 mm	455 mm	455 mm	455 mm	450 mm
motor power	400 V / 50 Hz / 7,5 kW	400 V / 50 Hz / 7,5 kW	400 V / 50 Hz / 7,5 kW	400 V / 50 Hz / 7,5 kW	400 V / 50 Hz / 7,5 kW
dimension (L x D x H)	1.750 x 2.250 x 1.400 mm	2.300 x 2.250 x 1.400 mm	2.800 x 2.250 x 1.400 mm	3.100 x 2.250 x 1.400 mm	3.600 x 2.250 x 1.400 mm
weight	2.000 kg	2.500 kg	3.000 kg	3.500 kg	4.000 kg
	<b>E-MTSK 1.100-6,0</b>	<b>E-MTSK 1.560-5,0</b>	<b>E-MTSK 2.060-4,0</b>	<b>E-MTSK 2.560-4,0</b>	<b>E-MTSK 3.060-4,0</b>
<b>EAN</b>	<b>4260364299557</b>	<b>4260364299564</b>	<b>4260364299571</b>	<b>4260364299588</b>	<b>4260364299595</b>
<b>Item No.</b>	<b>340 8116</b>	<b>340 8155</b>	<b>340 8204</b>	<b>340 8254</b>	<b>340 8304</b>

DRILLING

MILLING

TURNING

SAWING

GRINDING

BENDING

CUTTING / PRESSING

OTHER MACHINES

ACCESSORIES

# E - MTBS - MODELS

## MOTORIC GUILLOTINE SHEARS



PIC: E - MTBS 1.350-3,0

Motor-driven guillotine shears for material thicknesses up to 4 mm for cutting metals and other materials in sheet form. Motor, brake system with coolant system and clutch bell enable quiet operation and energy consumption has been reduced to a minimum.

### E - MTBS - MODELS

- » high-quality, heavy and stable welded steel construction
- » backgauge manual 750 mm travel with ball screw drive
- » safety system in the rear area
- » finger protection barrier
- » LED-working light in the cutting area
- » operation via foot pedal
- » hardened knife that can be used on both sides
- » emergency stop switch with mobile foot pedal
- » sheet metal handle arms

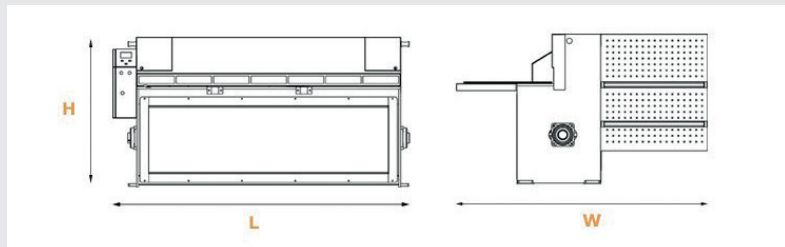

- » cutting performance data refer to 24 kg/m<sup>2</sup> sheet bending limit
- » sheet thickness for stainless steel: factor 0,5
- » sheet thickness for aluminum: factor 1,2

Description	E-MTBS 1.350-3,0	E-MTBS 2.050-3,0	E-MTBS 2.550-2,0	E-MTBS 3.050-2,0
sheet thickness (St 37)	max. 3,0 mm	max. 3,0 mm	max. 2,0 mm	max. 2,0 mm
working width	1.350 mm	2.050 mm	2.550 mm	3.050 mm
strokes per minute	35 mm/min	35 mm/min	35 mm/min	35 mm/min
motor power	400 V / 50 Hz / 3 kW	400 V / 50 Hz / 4 kW	400 V / 50 Hz / 7,5 kW	400 V / 50 Hz / 7,5 kW
table depth	390 mm	390 mm	390 mm	390 mm
table height	850 mm	850 mm	850 mm	850 mm
dimensions (L x D x H)	2.150 x 1.930 x 1.310 mm	2.150 x 2.700 x 1.310 mm	3.200 x 2.150 x 1.310 mm	3.700 x 2.150 x 1.310 mm
weight	1.260 kg	1.760 kg	1.960 kg	2.210 kg
	<b>E-MTBS 1.350-3,0</b>	<b>E-MTBS 2.050-3,0</b>	<b>E-MTBS 2.550-2,0</b>	<b>E-MTBS 3.050-2,0</b>
<b>EAN</b>	4260364294569	4260364294583	4260657650683	4260364296716
<b>Item No.</b>	340 7135	340 7203	340 7252	340 7302

More sizes are available on request.

# E-MTBS-MODELS

## MOTORIC GUILLOTINE SHEARS

PREMIUM-LINE



PIC: E -MTBS 3.050-4,0

Motorised guillotine shears for material thicknesses up to 4 mm for cutting metals and other materials in plate form. The motor, brake system with cooling system and clutch bell enable quiet operation, and energy consumption has also been reduced to a minimum.

### E-MTBS-MODELS

- » high-quality, heavy and stable welded steel construction
- » backgauge manual 750 mm travel with ball screw drive
- » safety system in the rear area
- » finger protection barrier
- » LED-working light in the cutting area
- » operation via foot pedal
- » hardened knife that can be used on both sides
- » cutting column adjustment from the front
- » emergency stop switch with mobile foot pedal
- » sheet metal handle arms

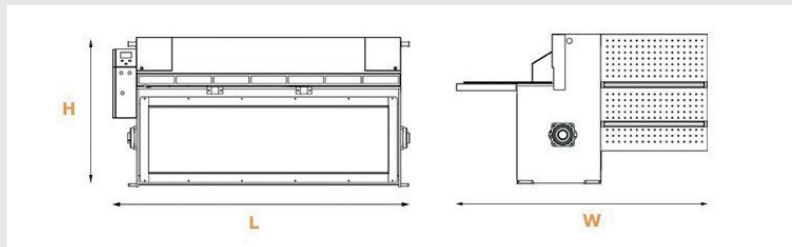

- » cutting performance data refer to 24 kg/m<sup>2</sup> sheet bending limit
- » sheet thickness for stainless steel: factor 0,5
- » sheet thickness for aluminum: factor 1,2

Description	E-MTBS 2.050-4,0	E-MTBS 2.550-4,0	E-MTBS 3.050-4,0
sheet thickness (St 37)	max. 4,0 mm	max. 4,0 mm	max. 4,0 mm
working width	2.050 mm	2.550 mm	3.050 mm
strokes per minute	41 mm/min	41 mm/min	41 mm/min
motor power	400 V / 50 Hz / 7,5 kW	400 V / 50 Hz / 7,5 kW	400 V / 50 Hz / 7,5 kW
table depth	455 mm	455 mm	455 mm
table height	850 mm	850 mm	850 mm
dimensions (L x D x H)	2.700 x 2.150 x 1.450 mm	3.200 x 2.150 x 1.450 mm	3.700 x 2.150 x 1.450 mm
weight	3.010 kg	3.510 kg	4.010 kg
	<b>E-MTBS 2.050-4,0</b>	<b>E-MTBS 2.550-4,0</b>	<b>E-MTBS 3.050-4,0</b>
<b>EAN</b>	<b>4260364294606</b>	<b>4260364296723</b>	<b>4260364296730</b>
<b>Item No.</b>	<b>340 7204</b>	<b>340 7254</b>	<b>340 7305</b>

More sizes are available on request.



# E-HTBS MODELS

## HYDRAULIC GUILLOTINE SHEARS

Hydraulic guillotine shears for cutting material thickness up to 20 mm.



PIC: E -HTBS 3.060-8

Guillotine Shears

### E-HTBS MODELS

- » high-quality, heavy and stable steel welding
- » hydraulics and valves from Bosch-Rexroth
- » double acting hydraulic cylinders
- » motorized backgauge with NC-control ELGO
- » light barrier safety system in the rear area
- » finger protection in the front
- » central cutting gap adjustment
- » operation via foot pedal
- » emergency stop switch with mobile foot pedal
- » sheet metal handles

### OPTIONAL ACCESSORIES

- » foldable finger guard
- » laser cut line display
- » sheet metal holder in the back
- » support arms with scale

» bending performance data refer to 24 kg/m<sup>2</sup> sheet bending limit  
» sheet thickness for stainless steel: factor 0,5

Description	E-HTBS 2.560-6	E-HTBS 3.060-6	E-HTBS 3.060-8	E-HTBS 3.660-6	E-HTBS 4.060-6
sheet thickness (St 37)	6 mm	6 mm	8 mm	6 mm	6 mm
working width	2.560 mm	3.060 mm	3.060 mm	3.660 mm	4.060 mm
table height	800 mm	800 mm	800 mm	800 mm	900 mm
cutting angle	1,6°	1,6°	1,8°	1,2°	1,2°
strokes per minute	15	17	17	20	23
motor power	11 kW	11 kW	15 kW	11 kW	11 kW
dimensions (L x D x H)	3.190 x 2.940 x 1.570 mm	3.690 x 3.000 x 1.570 mm	3.740 x 3.080 x 1.650 mm	4.400 x 3.080 x 1.650 mm	4.710 x 3.190 x 1.750 mm
weight	4.670 kg	5.450 kg	6.380 kg	7.300 kg	9.150 kg
	<b>E-HTBS 2.560-6</b>	<b>E-HTBS 3.060-6</b>	<b>E-HTBS 3.060-8</b>	<b>E-HTBS 3.660-6</b>	<b>E-HTBS 4.060-6</b>
<b>EAN</b>	<b>4260364298079</b>	<b>4260364298086</b>	<b>4260364298093</b>	<b>4260364298109</b>	<b>4260364298116</b>
<b>Item No.</b>	<b>311 1256</b>	<b>311 1306</b>	<b>311 1308</b>	<b>311 1366</b>	<b>311 1406</b>

# E-HSTS MODELS

## HYDRAULIC GUILLOTINE SHEARS



PIC: E -HSTS 3.060-13

### E-HSTS MODELS

- » very heavy, rigid machine for professional continuous operation
- » backgauge 1,000 mm, digitally controllable
- » front supports and support arm 1,000 mm with T-slot and scale
- » work table with filler plates and roller balls
- » upper knife with 2 cutting edges stroke
- » upper knife adjustable to increase the number of cuts
- » digital stroke counter
- » lower knife with 4 cutting edges settings
- » knife gap manua
- » shadow line device with fluorescent illumination
- » transparent finger guard and side neck guard
- » foot pedal control for single cut and cycle
- » emergency stop button

Description	E-HSTS 3.060-6	E-HSTS 3.060-10	E-HSTS 3.060-13	E-HSTS 3.060-16	E-HSTS 3.060-20	E-HSTS 4.060-13
sheet thickness (St 37)	6 mm	10 mm	13 mm	16 mm	20 mm	13 mm
working width	3.060 mm	3.060 mm	3.060 mm	3.060 mm	3.060 mm	4.060 mm
table height	800 mm	800 mm	900 mm	900 mm	900 mm	900 mm
cutting angle	1,5°	2°	2,4°	2,7°	3°	2,2°
strokes per minute	17	17	17	17	18	23
motor power	11 kW	22 kW	30 kW	30 kW	37 kW	30 kW
dimensions (L x D x H)	3.770 x 3.100 x 1.825 mm	3.850 x 3.275 x 1.850 mm	3.880 x 3.485 x 2.060 mm	3.840 x 3.550 x 2.230 mm	3.900 x 3.540 x 2.230 mm	4.830 x 3.375 x 2.160 mm
weight	7.000 kg	8.900 kg	11.500 kg	15.500 kg	19.600 kg	16.100 kg
	<b>E-HSTS 3.060-6</b>	<b>E-HSTS 3.060-10</b>	<b>E-HSTS 3.060-13</b>	<b>E-HSTS 3.060-16</b>	<b>E-HSTS 3.060-20</b>	<b>E-HSTS 4.060-13</b>
<b>EAN</b>	4260364298130	4260364298147	4260364298154	4260364298161	4260364298178	4260364298185
<b>Item No.</b>	311 2306	311 2310	311 2313	311 2316	311 2320	311 2413

# E-HTS CNC-MODELS

## HYDRAULIC GUILLOTINE SHEARS

PREMIUM-LINE



PIC: E-HTS 6.070-6

CNC guillotine shear with splitter cut. Adjustment of cutting angle and backgauge via the control.

### E-HTS MODELS

- » high-quality, heavy and stable welded steel construction
- » hydraulics and valves from Bosch-Rexroth
- » double-acting hydraulic cylinders
- » with hydraulic drive and splitter cutting system
- » CNC control Cybelec 8W
- » motorised backgauge 6 - 750 mm
- » light barrier safety system at the rear
- » finger guard at the front (first segment, 1.000 mm, hinged)
- » automatic cutting gap adjustment
- » cutting angle adjustment
- » foot pedal operation (with emergency stop switch)
- » single and continuous stroke operable via foot pedal
- » tip operation with push buttons on the control panel
- » table structure closed version, with exchangeable support plates and ball castors
- » side stop 1.000 mm with T-slot, flip-stop and millimetre scale
- » angle stop and 2 sheet metal handle arms at the front
- » 1 set of blades mounted, for cutting steel up to strength 450 kg/m<sup>2</sup>

Description	E-HTS 3.070-6	E-HTS 3.070-10	E-HTS 3.070-13	E-HTS 3.070-16	E-HTS 3.070-20	E-HTS 3.070-25
sheet thickness (St 37)	6 mm	10 mm	13 mm	16 mm	20 mm	25 mm
working width	3.070mm	3.070 mm	3.070 mm	3.070mm	3.070 mm	3.070 mm
table height	800 mm	800 mm	800 mm	900 mm	1.000 mm	1.100 mm
cutting angle	0,5 - 1,5°	0,5 - 2,0°	0,5 - 2,5°	0,5 - 3,0°	0,5 - 3,0°	0,5 - 3,5°
strokes per minute	20 - 32	12 - 18	9 - 14	8 - 14	6 - 10	4 - 6
motor power	11 kW	22 kW	30 kW	11 kW	22 kW	30 kW
dimensions (L x D x H)	3.930 x 3.190 x 2.040 mm	3.930 x 3.300 x 2.220 mm	3.950 x 3.385 x 2.300 mm	3.930 x 3.380 x 2.040 mm	3.930 x 3.620 x 2.220 mm	3.950 x 3.605 x 2.300 mm
weight	7.800 kg	11.000 kg	13.000 kg	7.800 kg	11.000 kg	13.000 kg
	E-HTS 3.070-6	E-HTS 3.070-10	E-HTS 3.070-13	E-HTS 3.070-16	E-HTS 3.070-20	E-HTS 3.070-25
<b>EAN</b>	<b>4260364297959</b>	<b>4260364297966</b>	<b>4260364297973</b>	<b>4260364299991</b>	<b>4260364297003</b>	<b>4260364297010</b>
<b>Item No.</b>	<b>311 3306</b>	<b>311 3310</b>	<b>311 3313</b>	<b>311 3316</b>	<b>311 3320</b>	<b>311 3325</b>

Description	E-HTS 4.070-6	E-HTS 4.070-10	E-HTS 4.070-13	E-HTS 4.070-16	E-HTS 4.070-20
sheet thickness (St 37)	6 mm	10 mm	13 mm	16 mm	20 mm
working width	4.070 mm	4.070 mm	4.070 mm	4.070 mm	4.070 mm
table height	900 mm	900 mm	1.000 mm	1.000 mm	1.100 mm
cutting angle	0,5 - 1,5°	0,5 - 2,0°	0,5 - 2,5°	0,5 - 3,0°	0,5 - 3,0°
strokes per minute	16 - 25	9 - 14	7 - 14	7 - 12	6 - 9
motor power	11 kW	22 kW	30 kW	30 kW	37 kW
dimensions (L x D x H)	4.890 x 3.450 x 2.250 mm	4.930 x 3.380 x 2.260 mm	4.950 x 3.645 x 2.630 mm	4.970 x 3.630 x 2.800 mm	4.980 x 3.630 x 2.900 mm
weight	12.000 kg	15.000 kg	18.000 kg	23.500 kg	26.000 kg
	E-HTS 4.070-6	E-HTS 4.070-10	E-HTS 4.070-13	E-HTS 4.070-16	E-HTS 4.070-20
<b>EAN</b>	<b>4260364297980</b>	<b>4260364297997</b>	<b>4260364298000</b>	<b>4260364298017</b>	<b>4260364298024</b>
<b>Item No.</b>	<b>311 3406</b>	<b>311 3410</b>	<b>311 3413</b>	<b>311 3416</b>	<b>311 3420</b>

Description	E-HTS 6.070-6	E-HTS 6.070-10	E-HTS 6.070-13	E-HTS 6.070-16	E-HTS 6.070-20
sheet thickness (St 37)	6 mm	10 mm	13 mm	16 mm	20 mm
working width	6.070 mm	6.070 mm	6.070 mm	6.070 mm	6.070 mm
table height	1.000 mm	1.000 mm	1.200 mm	1.200 mm	1.200 mm
cutting angle	0,5 - 2,0°	0,5 - 2,0°	0,5 - 2,5°	0,5 - 3,0°	1,0 - 3,0°
strokes per minute	12 - 18	6 - 10	6 - 10	5 - 9	5 - 9
motor power	18,5 kW	22 kW	30 kW	37 kW	37 kW
dimensions (L x D x H)	6.870 x 4.130 x 2.690 mm	6.950 x 4.045 x 2.800 mm	6.950 x 4.200 x 3.090 mm	6.980 x 4.420 x 3.250 mm	7.010 x 4.280 x 3.330 mm
weight	22.000 kg	30.000 kg	38.000 kg	42.000 kg	46.000 kg
	E-HTS 6.070-6	E-HTS 6.070-10	E-HTS 6.070-13	E-HTS 6.070-16	E-HTS 6.070-20
<b>EAN</b>	<b>4260364298031</b>	<b>4260364298048</b>	<b>4260364297027</b>	<b>4260364298055</b>	<b>4260364298062</b>
<b>Item No.</b>	<b>311 3606</b>	<b>311 3610</b>	<b>311 3613</b>	<b>311 3616</b>	<b>311 3620</b>

## E-WSA-MODELS WATERJET CUTTING MACHINES

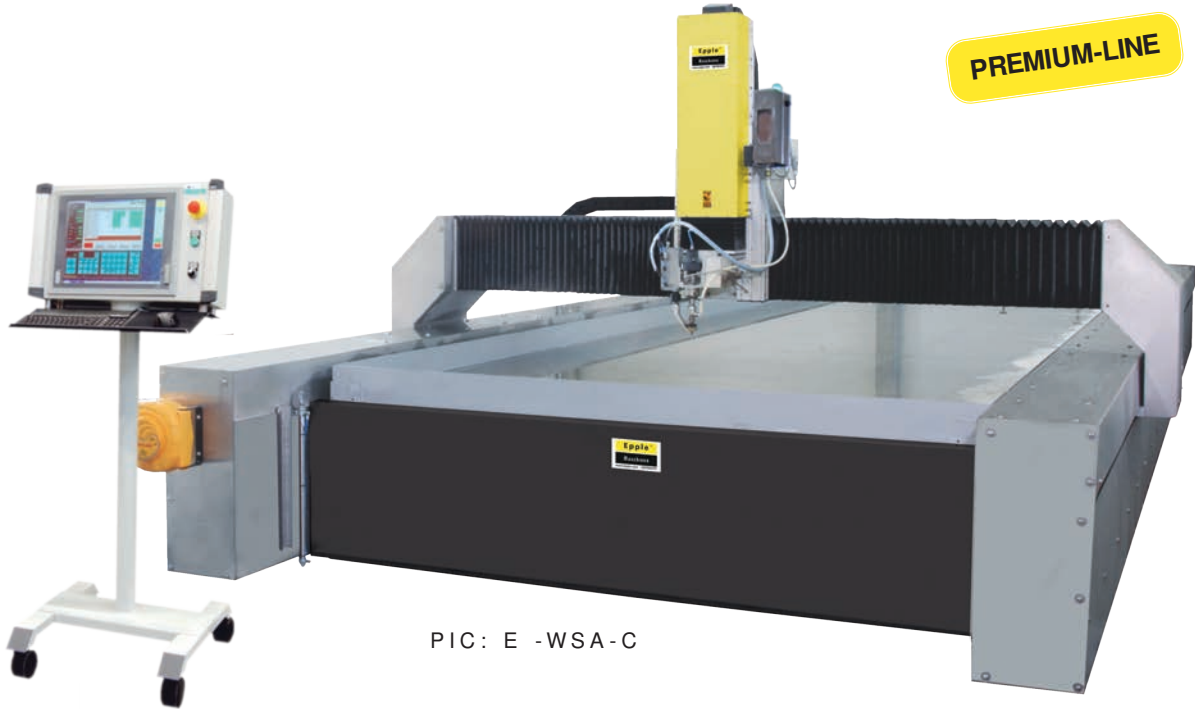

PIC: E -WSA -C

### E-WSA MODELS

High-pressure waterjet cutting machines for a wide range of materials/material thicknesses in 2- to 5-axis design.

- » extremely robustly constructed machines in gantry design.
- » work table with water basin in upright design for easy accessibility and safe workpiece support
- » table lengths up to 30.000 mm, widths up to 4.000 mm
- » cutting with ultrapure water or abrasive possible
- » pump systems up to 4.130 bar, litre capacities up to 7,5 l/min

These waterjet cutting machines are produced individually according to required and feasible size. All models are equipped with CNC control.

Description	E-WSA-L	E-WSA-S	E-WSA-U	E-WSA-C
cutting range	by arrangement, max. x 2.000 mm	by arrangement, max. x 2.500 mm	by arrangement, max. x 4.500 mm	by arrangement, max. 30.000 x 4.000 mm
positioning accuracy	+/- 0,05 mm	+/- 0,05 mm	+/- 0,04 mm	+/- 0,04 mm
repeatability	+/- 0,04 mm	+/- 0,04 mm	+/- 0,03 mm	+/- 0,03 mm
feed rate X/Y max.	12.000 mm	12.000 mm	16.000 mm	20.000 mm
rapid traverse X/Y max.	30.000 mm	30.000 mm	20.000 mm	30.000 mm
table load	On request	On request	On request	On request
path vertical axis	200 mm	200 mm	200 mm optional 700 mm	500 mm optional 700 mm



# E-WSA-MODELS

## WATERJET CUTTING MACHINES

### MODEL E-WSA-L

Low-cost machine for cutting parts two-dimensionally. Available for travels from 1.000 x 2.000 mm to 1.000 x 10.000 mm. Execution in welded steel construction. Motion axes with linear guides, hardened racks and pinions, driven by servo motors and gears. Equipped with compact table for cutting with pure water or optionally with dosing device for abrasive.

### MODEL E-WSA-S

Basic design as model E-WSA-L, but designed for the use of abrasive as standard. Machine can be extended, for example with a second cutting head. Optionally, the machine is available with equipment for clear water only.

### MODEL E-WSA-U

Load-bearing substructure in very robust steel design, crossbeam in stable aluminium design. Movement of the axes via ball slides on linear guides, feed via hardened racks and pinions made of stainless steel. Drive via servo motors and precision planetary gears. Machine is equipped with stainless steel cladding and protective bellows. Proportional abrasive dosing device is included as standard.

### MODEL E-WSA-C

For three-dimensional cutting thicknesses up to 320 mm, two-dimensional up to 500 mm. Construction in extremely robust all-steel design, low-lying longitudinal crosshead guide for best stability with precise linear guides. Feeds via powerful servo motors and precision gears via hardened and ground racks and pinions. Additionally equipped with linear measuring system. Proportional abrasive dosing device included as standard.

Depending on the requirements, the machines are equipped with different pumps, which are offered separately:

Maximum power	1,1 kW	2,2 kW	3,8 kW	5,7 kW	7,5 kW
Maximum pressure	4.100 bar	4.100 bar	4.100 bar	4.100 bar	4.100 bar
Maximum size of cutting nozzle	1 x 7	1 x 10	1 x 14 or 2 x 10	1 x 17 or 2 x 12	1 x 19 or 2 x 14

## E-PPSM-MODELS

### PRECISION PLASMA CUTTING MACHINES



PIC: E - PPSM 1.503

#### E-PPSM-MODELS

- » high-precision plasma cutting technology
- » high mechanical accuracy up to +/- 0,05
- » axis positioning speed: 30 m/min
- » travel of the x- and y-axis on precision ball guides
- » torch height adjustment with ball screws on double linear guides
- » patented crash protection on the torch
- » fast and precise positioning with brushless AC servo motors (x-axis with one drive and y-axis with two synchronised drives)
- » cutting table independently constructed from bridge and machine frame to ensure positioning accuracy under any table load
- » automatic torch height control
- » sectional cutting table with automatic fume extraction system
- » Windows-based CNC unit
- » automatic nesting software
- » remote control option for large tables
- » optional dust and fume extraction units according to safety regulations
- » flame-cutting table in sturdy steel construction
- » control panel free-standing, thus no thermal or mechanical influences from the cutting area
- » bridge driven on both sides
- » high-quality linear guides on all axes
- » dynamic AC servo drives on all axes with maintenance-free and backlash-free planetary gears.
- » helical rack drives designed for continuous operation are low-wear and virtually maintenance-free
- » optimum web speed even with fine contours and tight radii

# E-PPSM-MODELS

## PRECISION PLASMA CUTTING MACHINES

**PREMIUM-LINE**

Description	E-PPSM 1503	E-PPSM 2004	E-PPSM 2006	E-PPSM 2504	E-PPSM 2506
table size	3.200 x 1.550 mm	4.800 x 2.200 mm	6.400 x 2.200 mm	4.800 x 2.700 mm	6.400 x 2.700 mm
table height	750 mm	750 mm	750 mm	750 mm	750 mm
distance longitudinal axis	3.200 mm	4.200 mm	6.200 mm	4.200 mm	6.200 mm
distance transverse axis	1.550 mm	2.200 mm	2.200 mm	2.700 mm	2.700 mm
dimensions	5.200 x 3.000 x 1.800 mm	6.200 x 3.500 x 1.800 mm	8.200 x 3.500 x 1.800 mm	6.200 x 4.000 x 1.800 mm	8.200 x 4.000 x 1.800 mm
weight (approx.)	2.800 kg	3.500 kg	4.100 kg	4.050 kg	4.750 kg
Description	E-PPSM 1503	E-PPSM 2004	E-PPSM 2006	E-PPSM 2504	E-PPSM 2506
<b>EAN</b>	4260364299601	4260364299618	4260364299625	4260364299632	4260364299649
<b>Item No.</b>	313 5031	313 5042	313 5062	313 5043	313 5063

Description	E-PPSM 3006	E-PPSM 3009	E-PPSM 3012	E-PPSM 3014
table size	6.400 x 3.200 mm	9.600 x 3.200 mm	12.800 x 3.200 mm	14.400 x 3.200 mm
table height	750 mm	750 mm	750 mm	750 mm
distance longitudinal axis	6.200 mm	9.200 mm	12.200 mm	14.200 mm
distance transverse axis	3.200 mm	3.200 mm	3.200 mm	3.200 mm
dimensions	8.200 x 4.500 x 1.800 mm	11.200 x 4.500 x 1.800 mm	14.200 x 4.500 x 1.800 mm	16.000 x 4.500 x 1.800 mm
weight	5.400 kg	7.100 kg	8.700 kg	9.500 kg
Description	E-PPSM 3006	E-PPSM 3009	E-PPSM 3012	E-PPSM 3014
<b>EAN</b>	4260364299656	4260364299663	4260364299670	4260364299687
<b>Item No.</b>	313 5064	313 5093	313 5123	313 5143

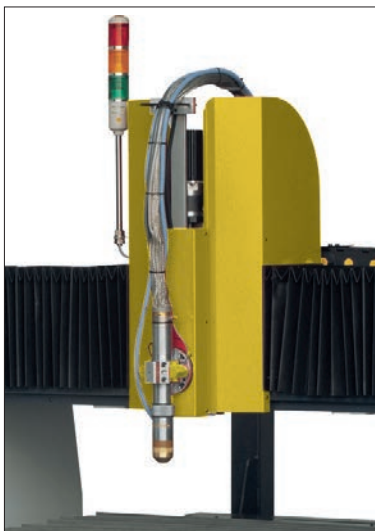

DRILLING

MILLING

TURNING

SAWING

GRINDING

BENDING

CUTTING / PRESSING

OTHER MACHINES

ACCESSORIES

## E-IPSM-MODELS PLASMA CUTTING MACHINES

PREMIUM-LINE



PIC: E-IPSM 3012 WITH SPECIAL ACCESSORIES  
ROUND CUTTING DEVICE

**E-IPSM** plasma cutting systems are designed for the highest requirements in fine plasma cutting. They are based on the plasma source HYPERTHERM "HPR 130 XD" which enables flame cutting of sheet thicknesses in the range of 0.5 to 38 mm. For unalloyed materials and thicknesses up to 32 mm, laser-like cutting qualities are achieved. The cutting table is designed for thin and medium sheets - loading capacity up to 1.580 kg/m<sup>2</sup>. The precision of the machine is guaranteed by double linear guides.

#### Standard accessories

- » plasma source HYPERTHERM „HPR 130-XD“
- » automatic gas console
- » automatic workpiece alignment by means of laser
- » torch height sensor system for the perfect cut
- » CNC unit HYPERTHERM „MicroEdge Pro“
- » user software: HYPERTHERM „ProNest 2012“ with „TRUE HOLE“ Technology
- » position accuracy: +/- 0,2 mm
- » linear rail width: 20 mm
- » cutting current: 20-130 A
- » connected load: 32 kVA

From 8.000 mm travel, the machines have two cutting heads. Thus double the cutting capacity is available. Simultaneous machining with two cutting heads significantly increases the productivity of the machine.

#### Special accessories

- » second cutting head
- » pipe cutting device

# Overview Technical Data

## E-IPSM - Machines

Description	E-IPSM 3006	E-IPSM 3008	E-IPSM 3012	E-IPSM 3014
table size	6.400 x 3.200 mm	8.000 x 3.200 mm	12.800 x 3.200 mm	14.400 x 3.200 mm
table height	750 mm	750 mm	750 mm	750 mm
distance longitudinal axis	6.400 mm	8.000 mm	12.800 mm	14.400 mm
distance transverse axis	3.200 mm	3.200 mm	3.200 mm	3.200 mm
dimensions	8.000 x 5.200 x 1.900 mm	10.000 x 5.200 x 1.900 mm	14.000 x 5.200 x 1.900 mm	16.000 x 5.200 x 1.900 mm
weight	4.100 kg	5.600 kg	7.050 kg	7.800 kg
	E-IPSM 3006	E-IPSM 3008	E-IPSM 3012	E-IPSM 3014
<b>EAN</b>	<b>4260364298680</b>	<b>4260364298703</b>	<b>4260364298734</b>	<b>4260364298758</b>
<b>Item No.</b>	<b>313 4063</b>	<b>313 4083</b>	<b>313 4123</b>	<b>313 4143</b>

Description	E-IPSM 3016	E-IPSM 4006	E-IPSM 4008	E-IPSM 4010
table size	17.600 x 3.200 mm	6.400 x 4.400 mm	8.000 x 4.400 mm	11.200 x 4.400 mm
table height	750 mm	750 mm	750 mm	750 mm
distance longitudinal axis	17.600 mm	6.400 mm	8.000 mm	11.200 mm
distance transverse axis	3.200 mm	4.400 mm	4.400 mm	4.400 mm
dimensions	18.000 x 5.200 x 1.900 mm	8.000 x 6.200 x 1.900 mm	10.000 x 6.200 x 1.900 mm	12.000 x 6.200 x 1.900 mm
weight	9.100 kg	5.900 kg	8.200 kg	9.300 kg
	E-IPSM 3016	E-IPSM 4006	E-IPSM 4008	E-IPSM 4010
<b>EAN</b>	<b>4260364298772</b>	<b>4260364298697</b>	<b>4260364298710</b>	<b>4260364298727</b>
<b>Item No.</b>	<b>313 4163</b>	<b>313 4064</b>	<b>313 4084</b>	<b>313 4104</b>

Description	E-IPSM 4012	E-IPSM 4014	E-IPSM 4016	E-IPSM 4018
table size	12.800 x 4.400 mm	14.400 x 4.400 mm	17.600 x 4.400 mm	19.200 x 4.400 mm
table height	750 mm	750 mm	750 mm	750 mm
distance longitudinal axis	12.800 mm	14.400 mm	17.600 mm	19.200 mm
distance transverse axis	4.400 mm	4.400 mm	4.400 mm	4.400 mm
dimensions	14.000 x 6.200 x 1.900 mm	16.000 x 6.200 x 1.900 mm	18.000 x 6.200 x 1.900 mm	20.000 x 6.200 x 1.900 mm
weight	10.450 kg	11.600 kg	13.700 kg	14.850 kg
	E-IPSM 4012	E-IPSM 4014	E-IPSM 4016	E-IPSM 4018
<b>EAN</b>	<b>4260364298741</b>	<b>4260364298765</b>	<b>4260364298789</b>	<b>4260364298796</b>
<b>Item No.</b>	<b>313 4124</b>	<b>313 4144</b>	<b>313 4164</b>	<b>313 4184</b>

DRILLING

MILLING

TURNING

SAWING

GRINDING

BENDING

CUTTING /  
PRESSING

OTHER  
MACHINES

ACCESSORIES



## E-LSA-MODELS LASER CUTTING MACHINES

**PREMIUM-LINE**



Laser Cutting Machines

### E-LSA

#### STRUCTURE AND FUNCTION

- » gantry linear system
- » dual-circuit water cooler
- » fibre optics power unit
- » Windows operating system
- » ergonomic machine design, CNC control separate
- » 6 MB program memory
- » work table with second workpiece support plate
- » programmable gas selection 1-25 bar
- » cutting head (with air admixture), lenses 5", 7.5" or 10" bore detection, cut monitoring and lens error message
- » automatic nozzle cleaning and calibration
- » fume extraction system included
- » cut-out waste conveyor
- » Lantek nesting system
- » safe construction (closed housing with warning light as standard)

#### Advantages at a glance

- low investment and operating costs
- most cost-effective solution for every requirement
- very easy to operate
- quick and easy installation
- fast loading and unloading
- high positioning accuracy
- reduction of non-productive time due to second clamping plate (shuttle table)
- continuous cutting with movable shuttle table
- optional shuttle tables in different sizes

## Overview Technical Data E-LSA - Machines

Description	E-LSA 3015 FI	E-LSA 4020 FI	E-LSA 4030 FI	E-LSA 6020 FI	E-LSA 6030 FI
cutting thickness - rolled steel	15 mm	15 mm	18 mm	18 mm	18 mm
cutting range	3.000 x 1.500 mm	4.000 x 2.000 mm	4.000 x 3.000 mm	6.000 x 2.000 mm	6.000 x 3.000 mm
table load	525 kg/m <sup>2</sup>	525 kg/m <sup>2</sup>	525 kg/m <sup>2</sup>	525 kg/m <sup>2</sup>	525 kg/m <sup>2</sup>
feed	210 m/min	210 m/min	210 m/min	210 m/min	210 m/min
rapid traverse x/y	310 m/min	310 m/min	310 m/min	310 m/min	310 m/min
positioning accuracy	+/- 0,08 mm	+/- 0,08 mm	+/- 0,08 mm	+/- 0,08 mm	+/- 0,08 mm
repeatability	+/- 0,03 mm	+/- 0,03 mm	+/- 0,03 mm	+/- 0,03 mm	+/- 0,03 mm
laser power	2 kW	2 kW	2 kW	2 kW	2 kW
dimensions (L x D x H)	10.500 x 6.550 x 2.250 mm	12.500 x 7.050 x 2.250 mm	12.500 x 8.050 x 2.250 mm	16.500 x 7.050 x 2.250 mm	16.500 x 8.050 x 2.250 mm
	<b>E-LSA 3015 FI</b>	<b>E-LSA 4020 FI</b>	<b>E-LSA 4030 FI</b>	<b>E-LSA 6020 FI</b>	<b>E-LSA 6030 FI</b>
<b>EAN</b>	4260364299205	4260364299212	4260364299229	4260364299236	4260364299243
<b>Item No.</b>	313 1312	313 1422	313 1432	313 1622	313 1632

Description	E-LSA 8020 FI	E-LSA 8030 FI	E-LSA 10020 FI	E-LSA 10030 FI	E-LSA 12030 FI
cutting thickness - rolled steel	18 mm	18 mm	18 mm	18 mm	18 mm
cutting range	8.000 x 2.000 mm	8.000 x 3.000 mm	10.000 x 2.000 mm	10.000 x 3.000 mm	12.000 x 3.000 mm
table load	525 kg/m <sup>2</sup>	525 kg/m <sup>2</sup>	525 kg/m <sup>2</sup>	525 kg/m <sup>2</sup>	525 kg/m <sup>2</sup>
feed	210 m/min	210 m/min	210 m/min	210 m/min	210 m/min
rapid traverse x/y	310 m/min	310 m/min	310 m/min	310 m/min	310 m/min
positioning accuracy	+/- 0,08 mm	+/- 0,08 mm	+/- 0,08 mm	+/- 0,08 mm	+/- 0,08 mm
repeatability	+/- 0,03 mm	+/- 0,03 mm	+/- 0,03 mm	+/- 0,03 mm	+/- 0,03 mm
laser power	2 kW	2 kW	2 kW	2 kW	2 kW
dimensions (L x D x H)	20.500 x 7.050 x 2.250 mm	20.500 x 8.050 x 2.250 mm	24.500 x 7.050 x 2.250 mm	24.500 x 8.050 x 2.250 mm	28.500 x 8.050 x 2.250 mm
	<b>E-LSA 8020 FI</b>	<b>E-LSA 8030 FI</b>	<b>E-LSA 10020 FI</b>	<b>E-LSA 10030 FI</b>	<b>E-LSA 12030 FI</b>
<b>EAN</b>	4260364299250	4260364299267	4260364299274	4260364299281	4260364299298
<b>Item No.</b>	313 1822	313 1832	313 1122	313 1132	313 1133

## Maximum cutting thicknesses

Material	1 kW	2 kW	3 kW	4 kW
steel	10 mm	16 mm	16 mm	20 mm
stainless steel	5 mm	8 mm	10 mm	12 mm
aluminium	3 mm	6 mm	8 mm	10 mm
copper	2 mm	4 mm	5 mm	6 mm
brass	2 mm	4 mm	5 mm	6 mm

DRILLING

MILLING

TURNING

SAWING

GRINDING

BENDING

CUTTING /  
PRESSING

OTHER  
MACHINES

ACCESSORIES

# E-HPS 40

## HYDRAULIC STEELWORKER

# Hydraulic Steelworkers

**NEW**

**PREMIUM-LINE**

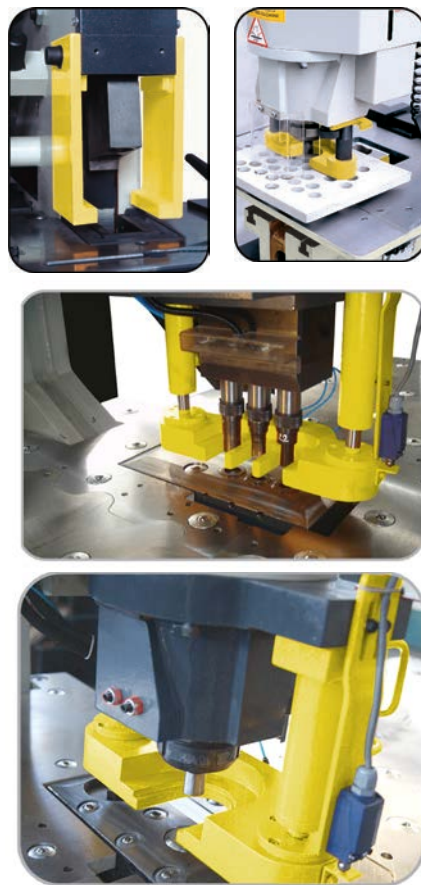

### E-HPS 40

- » 4 processing stations with foot control
- » cutting, notching and punching of angle iron, flat iron and bar material
- » central lubrication
- » high-quality, heavy and sturdy steel welded construction

» cutting performance data refer to 24 kg/m<sup>2</sup> sheet bending limit  
 » sheet thickness for stainless steel: factor 0,5  
 » sheet thickness for aluminum: factor 1,2

Description	E-HPS 40
cutting capacity	40 t
working range	175 mm
working stroke	50 mm
working height (hole punch)	970 mm
motor power	400 V / 50 Hz / 3 kW
dimensions (L x D x H)	1.100 x 800 x 1.520 mm
weight	580 kg
<b>E-HPS 40</b>	
<b>EAN</b>	<b>4260364296747</b>
<b>Item No.</b>	<b>353 0040</b>

Description	E-HPS 40
max. thickness diameter	20 x 15 mm
thickness diameter	30 x 10 mm
working stroke	50 mm
working height	970 mm
<b>sheet shear</b>	-
sheets	200 x 13 mm
sheets	300 x 6 mm
blade length	356 mm
shearing with angle	80 x 10 mm
working height	970 mm
<b>angel shear</b>	-
angle steel at 90°	80 x 80 x 8 mm
angle steel at 45°	50 x 6 mm
working height	1.110 mm
<b>steel bar sheer</b>	-
square	ø 30 mm
rectangular	25 mm

# E-HPS 45 / E-HPS 60

## HYDRAULIC STEELWORKERS

**PREMIUM-LINE**



PIC: E-HPS 60

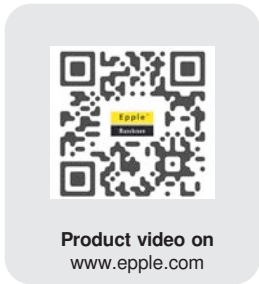

Product video on  
www.epple.com

Specify tool brand with your order:

- » Mubea
- » Kingsland
- » Peddinghaus

### E-HPS 45 / E-HPS 60 WITH 5 WORKSTATIONS

- » 5 processing stations with foot controller
- » punching, steel bar shearing, angle iron cropping, sheet metal shearing, notching
- » for fast working with short cycle times
- » heavy welded steel construction
- » motor 400 V / 4 kW



rod steel station  
with blank holder



angle iron station  
45/ 90° angle



punch station  
max. capacity 28 x 15 mm  
and 38 x 11mm



notching station  
Table with arrester and scales



flat steel station  
Table with angle arresters and  
adjustable blank holders

- » cutting performance data refer to 24 kg/m<sup>2</sup> sheet bending limit
- » sheet thickness for stainless steel: factor 0,5
- » sheet thickness for aluminum: factor 1,2

Description	E-HPS 45	E-HPS 60
cutting capacity	45 t	60 t
working range	175 mm	220 mm
working stroke	50 mm	55 mm
working height (hole punch)	935 mm	955 mm
motor power	400 V / 50 Hz / 4 kW	400 V / 50 Hz / 4 kW
dimensions (L x D x H)	1.430 x 950 x 1.680 mm	1.520 x 950 x 1.780 mm
weight	1.180 kg	1.440 kg
	<b>E-HPS 45</b>	<b>E-HPS 60</b>
EAN	4260364292503	4260364292510
Item No.	353 0045	353 0060



# E-HPS 55 / E-HPS 65

## HYDRAULIC STEELWORKER

**PREMIUM-LINE**

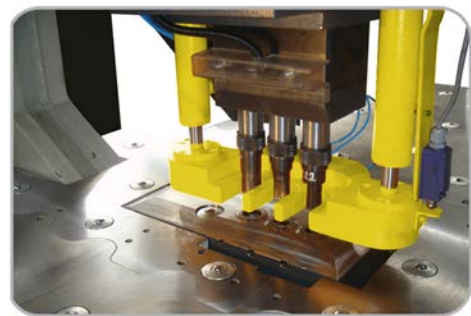
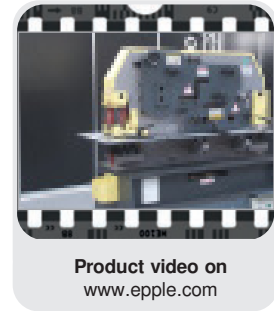

Hydraulic Steelworkers

PIC: E-HPS 65

### E-HPS 55 / E-HPS 65

- » 5 processing stations with foot controller
- » punching, steel bar shearing, angle iron cropping, sheet metal shearing, notching
- » for fast working with short cycle times
- » heavy welded steel construction
- » motor 400 V / 5,5 kW

#### Specify tool brand with your order:

- » Mubea
- » Kingsland
- » Peddinghaus

- » cutting performance data refer to 24 kg/m<sup>2</sup> sheet bending limit
- » sheet thickness for stainless steel: factor 0,5
- » sheet thickness for aluminum: factor 1,2

Description	E-HPS 55	E-HPS 65
cutting capacity	55 t	65 t
working range	255 mm	305 mm
working stroke	60 mm	55 mm
working height (hole punch)	1.030 mm	1.030 mm
motor power	400 V / 50 Hz / 5,5 kW	400 V / 50 Hz / 5,5 kW
dimensions (L x D x H)	1.500 x 950 x 1.880 mm	1.700 x 950 x 1.880 mm
weight	1.520 kg	1.600 kg
	<b>E-HPS 55</b>	<b>E-HPS 65</b>
EAN	4260364292527	4260364292534
Item No.	353 0055	353 0065



# E-HPS 65 V

## HYDRAULIC STEELWORKERS

NEW

PREMIUM-LINE



PIC: E-HPS 65 V

### E-HPS 65 V WITH 5 WORK STATIONS

- » 5 processing stations with foot controller
- » punching, steel bar shearing, angle iron cropping, sheet metal shearing, notching
- » for fast working with short cycle times
- » heavy welded steel construction
- » electric motor 400 V / 5,5 kW / 7,5 kW

- » cutting performance data refer to 24 kg/m<sup>2</sup> sheet bending limit
- » sheet thickness for stainless steel: factor 0,5
- » sheet thickness for aluminum: factor 1,2

### Specify tool brand with your order:

- » Mubea
- » Kingsland
- » Peddinghaus

Description	E-HPS 65 V
cutting capacity	65 t
working range	240 mm
working stroke	40 mm
working height	1.050 / 1.070 / 810 mm
motor power	400 V / 50 Hz / 5,5 kW
dimensions (L x D x H)	1.180 x 900 x 1.720 mm
weight	1.215 kg
	<b>E-HPS 65 V</b>
EAN	4260364296754
Item No.	353 0066

# E-HPS 85 / E-HPS 115 / E-HPS 175

## HYDRAULIC STEELWORKERS

**PREMIUM-LINE**



PIC: E-HPS 175

Hydraulic Steelworkers

### E-HPS 85 / E-HPS 115 / E-HPS 175 WITH 5 WORK STATIONS

- » 5 processing stations with foot controller
- » punching, steel bar shearing, angle iron cropping, sheet metal shearing, notching
- » with double cylinder
- » for fast working with short cycle times
- » heavy welded steel construction
- » electric motor 400 V / 7,5 - 11 kW

Specify tool brand with your order:

- » Mubea
- » Kingsland
- » Peddinghaus

- » cutting performance data refer to 24 kg/m<sup>2</sup> sheet bending limit
- » sheet thickness for stainless steel: factor 0,5
- » sheet thickness for aluminum: factor 1,2

Description	E-HPS 85	E-HPS 115	E-HPS 175
cutting capacity	85 t	115 t	175 t
working range	355 mm	355 mm	625 mm
working stroke	80 mm	80 mm	80 mm
working height (hole punch)	1.080 mm	1.110 mm	1.130 mm
motor power	400 V / 50 Hz / 7,5 kW	400 V / 50 Hz / 11 kW	400 V / 50 Hz / 11 kW
dimensions (L x D x H)	1.920 x 950 x 2.040 mm	2.040 x 950 x 2.180 mm	2.730 x 1.150 x 2.280 mm
weight	2.315 kg	2.920 kg	6.000 kg

	E-HPS 85	E-HPS 115	E-HPS 175
<b>EAN</b>	4260364292541	4260364292558	4260364292565
<b>Item No.</b>	353 0085	353 0115	353 0175

# Overview Technical Data

## E-HPS - Machines

Description	E-HPS 40	E-HPS 45	E-HPS 55	E-HPS 60	E-HPS 65
<b>hole punch</b>	-	-	-	-	-
max. thickness diameter	20 x 15 mm	22 x 15 mm	20 x 20 mm	28 x 15 mm	26 x 20 mm
thickness diameter	30 x 10 mm	38 x 8 mm	40 x 10 mm	38 x 11 mm	57 x 10 mm
working stroke	50 mm	50 mm	60 mm	55 mm	55 mm
working height	970 mm	935 mm	1.030 mm	955 mm	1.030 mm
<b>sheet shear</b>	-	-	-	-	-
sheet	200 x 13 mm	200 x 15 mm	200 x 20 mm	200 x 20 mm	300 x 20 mm
sheet	300 x 6 mm	300 x 12 mm	300 x 15 mm	300 x 15 mm	375 x 15 mm
blade length	356 mm	316 mm	317 mm	317 mm	380 mm
angle shear	80 x 10 mm	80 x 10 mm	80 x 15 mm	80 x 10 mm	100 x 15 mm
working height	980 mm	935 mm	900 mm	955 mm	900 mm
<b>steel profile shear</b>	-	-	-	-	-
angle iron at 90°	80 x 80 x 8 mm	100 x 100 x 10 mm	120 x 120 x 12 mm	120 x 120 x 12 mm	120 x 120 x 12 mm
angle iron at 45°	50 x 6 mm	70 x 6 mm	70 x 10 mm	80 x 8 mm	70 x 10 mm
working height	1.110 mm	1.140 mm	1.130 mm	1.155 mm	1.130 mm
<b>steel bar shear</b>	-	-	-	-	-
circular	ø 30 mm	ø 30 mm	ø 40 mm	ø 40 mm	ø 45 mm
square	25 mm	25 mm	40 mm	35 mm	45 mm
<b>notching</b>	-	-	-	-	-
material thickness	-	8 mm	10 mm	10 mm	10 mm
length	1.100 mm	1.430 mm	1.500 mm	1.520 mm	1.700 mm
depth	800 mm	950 mm	950 mm	950 mm	950 mm
working height	1.520 mm	1.680 mm	1.880 mm	1.780 mm	1.880 mm

Description	E-HPS 65 V	E-HPS 85	E-HPS 85 V	E-HPS 115	E-HPS 175
<b>hole punch</b>	-	-	-	-	-
max. thickness diameter	26 x 20 mm	33 x 20 mm	33 x 20 mm	34 x 26 mm	40 x 32 mm
thickness diameter	57 x 10 mm	57 x 12 mm	57 x 12 mm	55 x 16 mm	57 x 22 mm
working stroke	55 mm	80 mm	80 mm	80 mm	80 mm
working height	1.030 mm	1.080 mm	1.080 mm	1.110 mm	1.130 mm
<b>sheet shear</b>	-	-	-	-	-
sheet	300 x 20 mm	380 x 20 mm	380 x 20 mm	380 x 25 mm	380 x 30 mm
sheet	375 x 15 mm	480 x 15 mm	480 x 15 mm	600 x 15 mm	600 x 20 mm
blade length	380 mm	482 mm	482 mm	610 mm	610 mm
angle shear	100 x 15 mm	120 x 15 mm	120 x 15 mm	120 x 15 mm	120 x 15 mm
working height	900 mm	940 mm	940 mm	935 mm	810 mm
<b>steel profile shear</b>	-	-	-	-	-
angle iron at 90°	120 x 120 x 12 mm	150 x 150 x 15 mm	150 x 150 x 15 mm	150 x 150 x 16 mm	200 x 200 x 20 mm
angle iron at 45°	70 x 10 mm	80 x 8 mm	80 x 8 mm	80 x 10 mm	80 x 10 mm
working height	1.130 mm	1.200 mm	1.200 mm	1.215 mm	1.130 mm
<b>steel bar shear</b>	-	-	-	-	-
circular	ø 45 mm	ø 50 mm	ø 50 mm	ø 55 mm	ø 65 mm
square	45 mm	50 mm	50 mm	50 mm	55 mm
<b>notching</b>	-	-	-	-	-
material thickness	10 mm	13 mm	13 mm	13 mm	16 mm
length	1.800 mm	1.920 mm	1.800 mm	2.040 mm	2.730 mm
depth	900 mm	950 mm	1.050 mm	950 mm	1.150 mm
working height	1.880 mm	2.040 mm	1.880 mm	2.180 mm	2.280 mm

DRILLING

MILLING

TURNING

SAWING

GRINDING

BENDING

CUTTING /  
PRESSING

OTHER  
MACHINES

ACCESSORIES

## E-HLS 30 / E-HLS 65 / E-HLS 85 E-HLS 115 / E-HLS 175 HYDRAULIC HOLE PUNCHING MACHINES

**PREMIUM-LINE**



PIC: E-HLS 85

**E-HLS 30 / E-HLS 65 /  
E-HLS 85 / E-HLS 115 /  
E-HLS 175**

- » for punching sheets, flat and U-steel
- » heavy and stable welded construction
- » time-saving, stepless stroke adjustment
- » stamp holder
- » LED working light
- » C-clamps

- » cutting performance data refer to 24 kg/m<sup>2</sup> sheet bending limit
- » sheet thickness for stainless steel: factor 0,5
- » sheet thickness for aluminum: factor 1,2

Description	E-HLS 30	E-HLS 65	E-HLS 85	E-HLS 115	E-HLS 175
punching force	30 t	65 t	85 t	115 t	175 t
working range	625 mm	625 mm	625 mm	625 mm	625 mm
<b>punching diameter</b>					
max. thickness diameter	18 x 12 mm	26 x 20 mm	33 x 20 mm	34 x 26 mm	40 x 32 mm
<b>punching machine</b>					
thickness diameter	22 x 10 mm	57 x 10 mm	57 x 12 mm	55 x 16 mm	57 x 22 mm
working stroke	55 mm	55 mm	80 mm	80 mm	80 mm
no. of strokes at 20 mm	x 20	x 22	x 21	x 21	x 21
working height (hole punch)	1.030 mm	950 mm	950 mm	950 mm	950 mm
motor power	400 V / 50 Hz / 3 kW	400 V / 50 Hz / 5,5 kW	400 V / 50 Hz / 7,5 kW	400 V / 50 Hz / 11 kW	400 V / 50 Hz / 11 kW
dimensions (L x D x H)	1.160 x 900 x 1.560 mm	1.600 x 900 x 1.800 mm	1.850 x 950 x 1.920 mm	2.000 x 950 x 1.970 mm	2.700 x 1.120 x 2.160 mm
weight	1.200 kg	2.440 kg	3.270 kg	3.760 kg	5.270 kg
	<b>E-HLS 30</b>	<b>E-HLS 65</b>	<b>E-HLS 85</b>	<b>E-HLS 115</b>	<b>E-HLS 175</b>
<b>EAN</b>	4260364298826	4260364292596	4260364292602	4260364292619	4260364292626
<b>Item No.</b>	353 2030	353 2065	353 2085	353 2115	353 2175

# E-HLS DP - MODELS

## HYDRAULIC HOLE PUNCHING MACHINES

**PREMIUM-LINE**



PIC: E-HLS 115 DP

Description	E-HLS 65 DP	E-HLS 85 DP	E-HLS 115 DP	E-HLS 175 DP
punching force	2 x 65 t	2 x 85 t	2 x 115 t	2 x 175 t
dimensions (L x D x H)	1.900 x 950 x 1.800 mm	2.250 x 950 x 1.920 mm	2.350 x 950 x 1.970 mm	2.800 x 1.100 x 2.160 mm
weight	2.900 kg	3.700 kg	4.600 kg	6.750 kg
<b>EAN</b>	<b>4260364299762</b>	<b>4260364299779</b>	<b>4260364299786</b>	<b>4260364299793</b>
<b>Item No.</b>	<b>353 3065</b>	<b>353 3085</b>	<b>353 3115</b>	<b>353 3175</b>

### E-HLS DP - MODELS

On machines with two workstations (E-HLS DP) it is possible to work highly productively, either by two persons at the same time or by preparing different punching tools.

**Model E-HLS 30 only for single operation, all other models also with double station.**



DRILLING

MILLING

TURNING

SAWING

GRINDING

BENDING

CUTTING /  
PRESSING

OTHER  
MACHINES

ACCESSORIES



# DDP 2 / DDP 3 / DDP 5

## ARBOR PRESSES

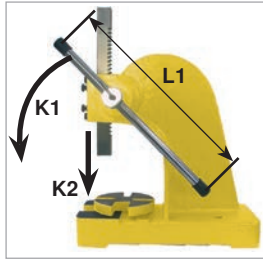

PIC: DDP 2



PIC: DDP 3



PIC: DDP 5

### DDP 2 / DDP 3 / DDP 5 HEAVY CASTING PRECISE

- » ideal for work- and repair shops
- » stable construction
- » body made of high-grade grey cast iron
- » suitable for molding in and crushing bearing, arbors, bushings, spindles and pins
- » for bending, flattening and broaching operations
- » turntable adjustable in four positions
- » variable adjustable lever rod
- » fixed on a working table

Description	DDP 2	DDP 3	DDP 5
max. height press	180 mm	285 mm	400 mm
working range	123 mm	163 mm	226 mm
table size round	155 mm	185 mm	255 mm
pusher size (W x D x H)	32 x 32 x 445 mm	38 x 38 x 615 mm	50 x 50 x 815 mm
largest mandrel hole	40 mm	44 mm	70 mm
allowable pressure	2 t	3 t	5 t
K1	e.g. 60 kg	e.g. 60 kg	e.g. 60 kg
K2	1.290 kg	1.186 kg	1.976 kg
L1	405 mm	540 mm	800 mm
dimensions (W x D x H)	260 x 432 x 445 mm	300 x 455 x 615 mm	376 x 645 x 815 mm
weight	32 kg	47 kg	120 kg

	DDP 2	DDP 3	DDP 5
<b>EAN</b>	<b>4260364292336</b>	<b>4260364292343</b>	<b>4260364292350</b>
<b>Item No.</b>	<b>225 8002</b>	<b>225 8003</b>	<b>225 8005</b>



# Horizontal And Vertical Press Brakes

# E-HBP 10

## MOBILE HYDRAULIC PRESSES

NEW

PREMIUM-LINE



PIC: E-HBP 10



PIC: E-HBP 10 WITH OPTIONAL STAND

Hydraulic Presses

### E-HBP 10

- » horizontal press for mobile use for bending various profiles
- » ideal for service vehicles
- » punch and die are hardened
- » simple stroke adjustment

### OPTIONAL ACCESSORIES

- » substructure for stationary use

Description	E-HBP 10
pressure	10 t
max. pressure	120 bar
min. distance compression die	110 mm
max. distance compression die	310 mm
height of pressure stamps	100 mm
motor power	230 V / 50 Hz / 1,5 kW
dimensions (L x D x H)	1200 x 250 x 400 mm
weight	80 kg
	<b>E-HBP 10</b>
<b>EAN</b>	<b>4260364299748</b>
<b>Item No.</b>	<b>353 0010</b>

# E-HBP 22 / E-HBP 40

## HORIZONTAL HYDRAULIC BENDING PRESSES



PIC: E-HBP 22



PIC: E-HBP 40

### E-HBP 22 / E-HBP 40

WITH UP TO 40 TONS BENDING PRESSURE

- » easy adjustable stroke length on the front side
- » massive and stable working table made of ground steel
- » hydraulic movable slide made of forged steel, tempered, ground and protected by dust scraper
- » machine operating by foot pedal or two-hand control
- » conic quick-change tool holder bolts made of hardened steel

### Example of use

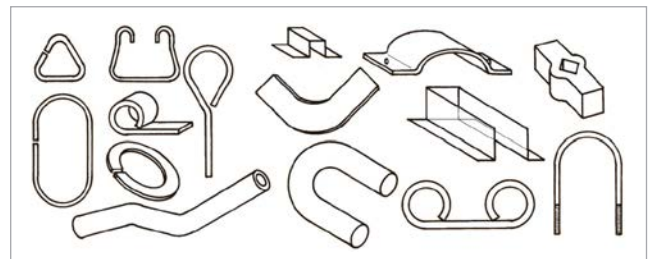

### E-HBP 40

#### OPTIONAL ACCESSORIES

- » alternatively also available with 7 stations pipe bending tools and NC control

Description	E-HBP 22	E-HBP 40
pressure	22 t	40 t
table size	625 x 1.100 mm	620 x 1.050 mm
stroke length	200 mm	250 mm
bending capacity flat steel	120 x 15 mm	160 x 20 mm
bending- / release speed	1.750 mm/min 2.000 mm/min	1.750 mm/min 2.000 mm/min
bolt height	120 mm	160 mm
bolt diameter	55 mm / 55 mm	55 mm / 63 mm
motor power	400 V / 50 Hz / 2,2 kW	400 V / 50 Hz / 4 kW
dimensions (L x D x H)	630 x 1.100 x 925 mm	700 x 1.150 x 950 mm
weight	635 kg	920 kg
	<b>E-HBP 22</b>	<b>E-HBP 40</b>
EAN	4260364292572	4260364292589
Item No.	353 1022	353 1040

# E-HBP 80 / E-HBP 100

## HYDRAULIC HORIZONTAL PRESSES

NEW

PREMIUM-LINE



PIC: E-HBP 80

### E-HBP 80 / E-HBP 100

HYDRAULIC HORIZONTAL PRESS WITH UP TO 80 TONS BENDING PRESSURE

- » pressure carriage made of forged steel hardened, with dust wiper
- » easily adjustable stroke from the front
- » slide stroke adjustment via hydraulic valves with handwheels
- » stroke adjustment also possible under working pressure
- » hardened tool holder pins made of alloy steel
- » operation via foot pedal or two-hand control possible

### OPTIONAL ACCESSORIES

- » special tools for bending tubes and flat steels in special bends or angle radii.
- » NC-control

Description	E-HBP 80	E-HBP 100
table size	520 x 620 mm	750 x 1.425 mm
table height	950 mm	930 mm
bolt height	280 mm	300 mm
pressure	80 t	100 t
max. pressure	300 bar	200 bar
Lifting speed under pressure	9 mm/s	9 mm/s
infeed / retraction speed	9 mm/s	10 mm/s
motor power	7,5 kW	10 kW
dimensions (W x D x H)	1.200 x 750 x 1.430 mm	1.500 x 750 x 1.800 mm
weight	1600 kg	1.700 kg
	<b>E-HBP 80</b>	<b>E-HBP 100</b>
<b>EAN</b>	<b>4260364299755</b>	<b>4260657650188</b>
<b>Item No.</b>	<b>353 2080</b>	<b>353 2100</b>



# HWP 16 / HWP-E 25

## VERTICAL HYDRAULIC PRESSES

**NEW**

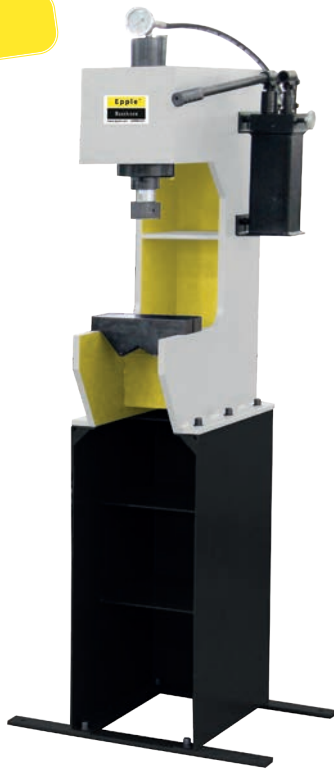

PIC: HWP 16



PIC: HWP-E 25

### HWP 16 / HWP-E 25

Machine concept in principle of a workshop press, but in C-design to be able to process long parts with minimum space requirement of the press.

Sturdy welded construction with substructure with side rails to securely fasten the machine to the floor.

Pressure build-up is manual via hand lever (model HWP 16) or motorised via foot pedal with emergency stop button on model HWP-E 25.

Two prism supports are included in the delivery.

Description	HWP 16
pressure	16 t
max. Pressure	16 t
stroke	160 mm
ram speed	0,8 mm per hand stroke
return stroke ram	15 mm/s
dimensions (W x D x H)	850 x 700 x 1.170 mm
weight	215 kg
	<b>HWP 16</b>
<b>EAN</b>	<b>4260657650690</b>
<b>Item No.</b>	<b>225 9016</b>

Description	HWP-E 25
pressure	25 t
max. Pressure	25 t
stroke	200 mm
ram speed	8,8 mm/s
return stroke ram	12,5 mm/s
motor power	2,2 kW
dimensions (W x D x H)	980 x 960 x 1.080 mm
weight	242 kg
	<b>HWP-E 25</b>
<b>EAN</b>	<b>4260657650706</b>
<b>Item No.</b>	<b>225 9025</b>

DRILLING

MILLING

TURNING

SAWING

GRINDING

BENDING

CUTTING / PRESSING

OTHER MACHINES

ACCESSORIES

## HWP 30 T / HWP E 30 T UNIVERSAL HYDAULIC PRESSES

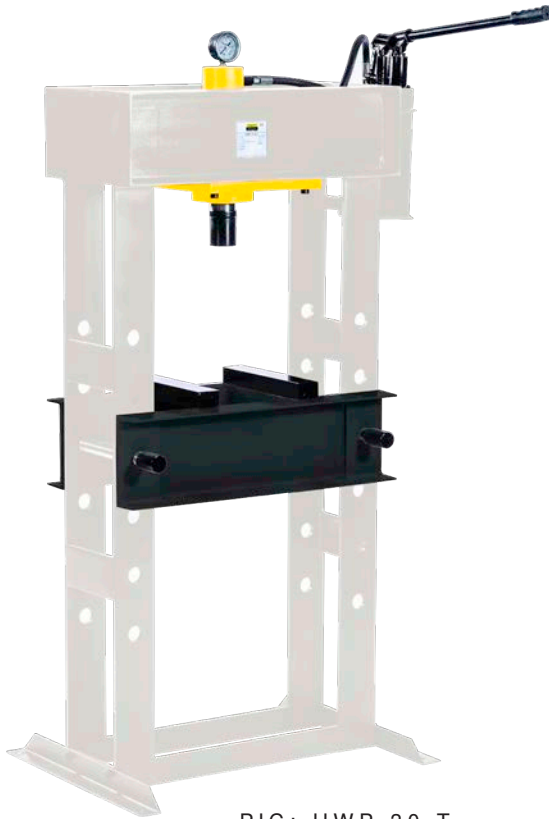

PIC: HWP 30 T



PIC: HWP E 30 T

### HWP 30 T / HWP E 30 T

- » for all reparation and maintenance work, adjusting of axes, bearings, arbors, pressing of bearings, bolts and bushings, press and squeeze work
- » stable welding construction
- » robust frame with boring for the adjustment of the press table
- » exceedingly precise hydraulic made in Europe
- » pressure build-up through actuating the pump lever manually (HWP 30 T)
- » with fixed chromed cylinder pistons
- » press pressure readable via manometer
- » with speeded up flow and automatic return of the piston

Description	HWP 30 T
pressure	30 t
max. pressure	7,5 t
working stroke	200 mm
working range	500 mm
table size	300 x 200 mm
dimensions (L x D x H)	770 x 610 x 1.670 mm
weight	320 kg
HWP 30 T	
EAN	4260364294675
Item No.	225 9031

Description	HWP-E 30 T
pressure	30 t
max. pressure	75 bar
working stroke	200 mm
working range	500 mm
table size	400 x 300 mm
motor power	400 V / 50 Hz / 3,0 kW
dimensions (L x D x H)	950 x 400 x 1.400 mm
weight	420 kg
HWP E 30 T	
EAN	4260364294682
Item No.	225 9030

# E-HWP 500-10 / E-HWP 500-20 E-HWP 600-30

## UNIVERSAL HYDRAULIC PRESSES



PIC: E-HWP 500-10



PIC: E-HWP 600-30

### E-HWP - MODELS

For all repair and assembly work, straightening of axes, girders, shafts, pressing and unloading of bearings, bolts and bushes, crimping and crushing, stress tests and welding tests.

- » stable welded construction
- » robust frame with perforation for adjustment of the press table
- » pressure build-up manual, pressure indication on manometer

Description	E-HWP 500-10	E-HWP 500-20	E-HWP 600-30
pressure	10 t	20 t	30 t
max. pressure	244 bar	244 bar	244 bar
working stroke	125 mm	125 mm	125 mm
cylinder dimensions	80 mm	85 mm	90 mm
working width (B)	400 mm	400 mm	550 mm
working depth (C)	190 mm	190 mm	190 mm
dimensions (L x D x H)	610 x 500 x 1.325 mm	610 x 750 x 1.600 mm	750 x 650 x 1.870 mm
weight	125 kg	150 kg	200 kg
	<b>E-HWP 500-10</b>	<b>E-HWP 500-20</b>	<b>E-HWP 600-30</b>
<b>EAN</b>	<b>4260364296778</b>	<b>4260364296785</b>	<b>4260364296792</b>
<b>Item No.</b>	<b>360 4601</b>	<b>360 4602</b>	<b>360 4603</b>

DRILLING

MILLING

TURNING

SAWING

GRINDING

BENDING

CUTTING /  
PRESSING

OTHER  
MACHINES

ACCESSORIES

# DIMENSIONS OF THE FOLLOWING WORKSHOP PRESSES

## E-HWP - MODELS

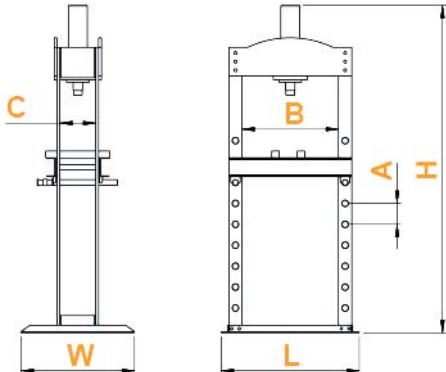

Description	E-HWP 500-10	E-HWP 500-20	E-HWP 600-30
A - hole distance	200 mm	200 mm	200 mm
B - working surface	600 mm	500 mm	600 mm
C - depth	285 mm	120 mm	120 mm
L - length	705 mm	850 mm	1.000 mm
W - depth	500 mm	750 mm	650 mm
H - height	920 mm	1.600 mm	1.870 mm

## E-WP - MODELS

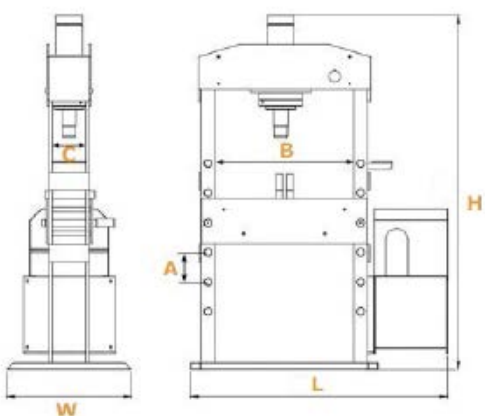

Description	E-WP 775-30	E-WP 1.040-60	E-WP 1.040-80	E-WP 1.070-100
A - hole distance	165 mm	165 mm	165 mm	190 mm
B - working surface	775 mm	1.040 mm	1.040 mm	1.070 mm
C - depth	190 mm	260 mm	260 mm	250 mm
L - length	1.500 mm	1.745 mm	1.810 mm	2.110 mm
W - depth	700 mm	700 mm	750 mm	1.000 mm
H - height	2.015 mm	2.100 mm	2.100 mm	2.290 mm

Description	E-WP 1.070-150	E-WP 1.570-100	E-WP 1.570-150	E-WP 1.570-200
A - hole distance	190 mm	190 mm	190 mm	250 mm
B - working surface	1.070 mm	1.570 mm	1.070 mm	1.570 mm
C - depth	290 mm	250 mm	290 mm	440 mm
L - length	2.110 mm	2.630 mm	2.630 mm	2.250 mm
W - depth	1.000 mm	1.000 mm	1.000 mm	1.165 mm
H - height	2.340 mm	2.290 mm	2.340 mm	2.860 mm

## E-WPK - MODELS

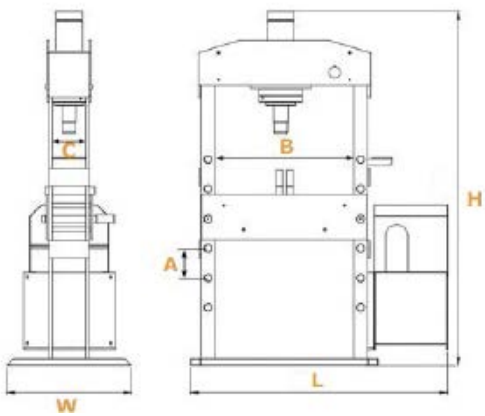

Description	E-WPK 1.040-80	E-WPK 1.070-100	E-WPK 1.070-150	E-WPK 1.570-150
A - hole distance	165 mm	190 mm	190 mm	190 mm
B - working surface	1.040 mm	1.070 mm	1.070 mm	1.570 mm
C - depth	260 mm	315 mm	360 mm	360 mm
L - length	1.810 mm	2.110 mm	2.110 mm	2.630 mm
W - depth	750 mm	1.000 mm	1.000 mm	1.000 mm
H - height	2.100 mm	2.430 mm	2.480 mm	2.480 mm

# DIMENSIONS OF THE FOLLOWING WORKSHOP PRESSES

## E-WPR - MODELS

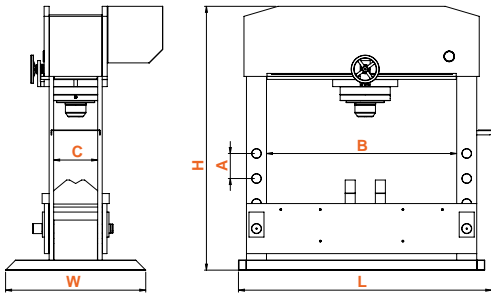

Description	E-WPR 1.570-100	E-WPK 1.570-150	E-WPK 1.900-200
A - hole distance	190 mm	190 mm	250 mm
B - working surface	1.570 mm	1.570 mm	1.900 mm
C - depth	315 mm	360 mm	440 mm
L - length	2.630 mm	2.630 mm	2.570 mm
W - depth	1.000 mm	1.000 mm	1.665 mm
H - height	2.625 mm	2.625 mm	2.860 mm

## E-UWP - MODELS

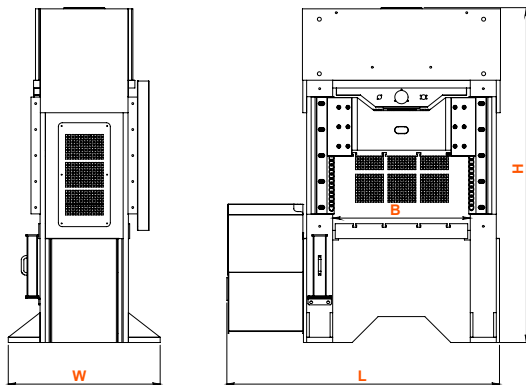

Description	E-UWP 1.020-100	E-UWP 1.020-150	E-UWP 1.520-100	E-UWP 1.520-150
A - hole distance	190 mm	190 mm	190 mm	190 mm
B - working surface	1.020 mm	1.020 mm	1.520 mm	1.520 mm
L - length	2.110 mm	2.110 mm	2.630 mm	2.630 mm
W - depth	1.000 mm	1.000 mm	1.000 mm	1.000 mm
H - height	2.350 mm	2.450 mm	2.350 mm	2.450 mm

## E-AP - MODELS

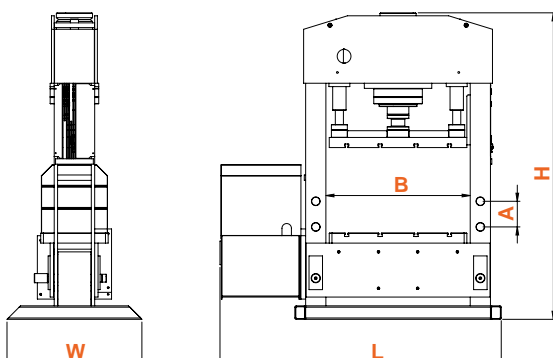

Description	E-AP 1.020-100	E-AP 1.020-150	E-AP 1.520-100	E-AP 1.520-150
A - hole distance	190 mm	190 mm	190 mm	190 mm
B - working surface	1.020 mm	1.020 mm	1.520 mm	1.520 mm
L - length	2.110 mm	2.110 mm	2.630 mm	2.630 mm
W - depth	1.000 mm	1.000 mm	1.000 mm	1.000 mm
H - height	2.275 mm	2.450 mm	2.275 mm	2.450 mm



# E-WP - MODELS

## UNIVERSAL HYDRAULIC WORKSHOP PRESSES

**PREMIUM-LINE**



PIC: E-WP 1.040-60

PIC: CYLINDER WITH TOOL

For technical data check page 273.

- |                                                                                                                                                                                                                                                                                                                             |                                                                                                 |
|-----------------------------------------------------------------------------------------------------------------------------------------------------------------------------------------------------------------------------------------------------------------------------------------------------------------------------|-------------------------------------------------------------------------------------------------|
| <p><b>E-WP - MODELS</b></p> <ul style="list-style-type: none"> <li>» steel welded construction</li> <li>» easy handling</li> <li>» arbitrarily stop position</li> <li>» pressure display</li> <li>» safety valve against overload</li> <li>» table height is adjustable</li> <li>» control with special joystick</li> </ul> | <p><b>OPTIONAL EQUIPMENT</b></p> <ul style="list-style-type: none"> <li>» foot pedal</li> </ul> |
|-----------------------------------------------------------------------------------------------------------------------------------------------------------------------------------------------------------------------------------------------------------------------------------------------------------------------------|-------------------------------------------------------------------------------------------------|



PIC: ADJUSTABLE HEIGHT



PIC: PRESSURE GAUGE DISPLAY

## E-WP - MODELS

### TECHNICAL DATA

Description	E-WP 775-30	E-WP 1.040-60	E-WP 1.040-80	E-WP 1.070-100
pressure	30 t	60 t	80 t	100 t
max. pressure	244 bar	236 bar	255 bar	263 bar
working stroke	200 mm	250 mm	250 mm	300 mm
cylinder dimensions	125 x 80 mm	180 x 120 mm	200 x 120 mm	220 x 160 mm
working speed	5 mm/sec	4 mm/sec	5 mm/sec	5 mm/sec
motor power	400 V / 50 Hz / 3 kW	400 V / 50 Hz / 4 kW	400 V / 50 Hz / 5,5 kW	400 V / 50 Hz / 5,5 kW
dimensions (L x D x H)	1.500 x 700 x 2.015 mm	1.745 x 700 x 2.100 mm	1.810 x 750 x 2.100 mm	2.110 x 1.000 x 2.290 mm
weight	400 kg	800 kg	835 kg	1.500 kg
<b>EAN</b>	<b>4260364294767</b>	<b>4260364294774</b>	<b>4260364294781</b>	<b>4260364294798</b>
<b>Item No.</b>	<b>360 4775</b>	<b>360 4104</b>	<b>360 4105</b>	<b>360 4107</b>

Description	E-WP 1.070-150	E-WP 1.570-100	E-WP 1.570-150	E-WP 1.570-200
pressure	150 t	100 t	150 t	200 t
max. pressure	244 bar	263 bar	244 bar	283 bar
working stroke	300 mm	300 mm	300 mm	300 mm
cylinder dimensions	280 x 200 mm	220 x 160 mm	280 x 200 mm	300 x 210 mm
working speed	5 mm/sec	5 mm/sec	5 mm/sec	5 mm/sec
motor power	400 V / 50 Hz / 11 kW	400 V / 50 Hz / 5,5 kW	400 V / 50 Hz / 11 kW	400 V / 50 Hz / 15 kW
dimensions (L x D x H)	2.110 x 1.000 x 2.340 mm	2.630 x 1.000 x 2.290 mm	2.630 x 1.000 x 2.430 mm	2.250 x 1.165 x 2.860 mm
weight	1.870 kg	1.600 kg	2.100 kg	4.500 kg
<b>EAN</b>	<b>4260364294811</b>	<b>4260364804</b>	<b>4260364294828</b>	<b>4260364296808</b>
<b>Item No.</b>	<b>360 4108</b>	<b>360 4157</b>	<b>360 4158</b>	<b>360 4161</b>

## E-WPK - MODELS

### UNIVERSAL HYDRAULIC WORKSHOP PRESSES

**PREMIUM-LINE**



PIC: E-WPK 1.570-100

#### E-WPK - MODELS

##### UNIVERSAL HYDRAULIC WORKSHOP PRESSES

- » steel welded construction
- » easy handling
- » arbitrarily stop position
- » pressure display
- » safety valve against overload
- » table height is adjustable
- » table up and down device
- » control with special joystick

#### OPTIONAL ACCESSORIES

- » two-hand-control
- » foot pedal

Description	E-WPK 1.070-100	E-WPK 1.070-150	E-WPK 1.570 - 100	E-WPK 1.570-150
pressure	100 t	150 t	100 t	150 t
max. pressure	263 bar	244 bar	244 bar	244 bar
working stroke	300 mm	300 mm	300 mm	300 mm
cylinder dimensions	260 x 160 mm	280 x 200 mm	280 x 200 mm	280 x 200 mm
working speed	5 mm/sec	5 mm/sec	5 mm/sec	5 mm/sec
motor power	400 V / 50 Hz / 5,5 kW	400 V / 50 Hz / 11 kW	400 V / 50 Hz / 5,5 kW	400 V / 50 Hz / 11 kW
dimensions (L x D x H)	2.110 x 1.000 x 2.430 mm	2.110 x 1.000 x 2.480 mm	2.630 x 1.000 x 2.480 mm	2.630 x 1.000 x 2.480 mm
weight	1.500 kg	1.870 kg	1.980 kg	2.100 kg
	<b>E-WPK 1.070-100</b>	<b>E-WPK 1.070-150</b>	<b>E-WPK 1.570-100</b>	<b>E-WPK 1.570-150</b>
<b>EAN</b>	<b>4260364296822</b>	<b>4260364296839</b>	<b>4260364298291</b>	<b>4260364296846</b>
<b>Item No.</b>	<b>360 4109</b>	<b>360 4110</b>	<b>360 4159</b>	<b>360 4160</b>

# E-WPR - MODELS

## UNIVERSAL HYDRAULIC WORKSHOP PRESSES

**PREMIUM-LINE**



PIC: E-WPR 1.570-150

### E-WPR - MODELS

#### UNIVERSAL HYDRAULIC WORKSHOP PRESSES

- » steel welded construction
- » easy handling
- » arbitrarily stop position
- » pressure display
- » safety valve against overload
- » table height is adjustable
- » control with special joystick
- » hydraulic cylinder laterally adjustable via handwheel

#### OPTIONAL ACCESSORIES

- » two-hand-control
- » foot pedal

Description	E-WPR 1.570-100	E-WPR 1.570-150	E-WPR 1.900-200
pressure	100 t	150 t	200 t
max. pressure	263 bar	244 bar	283 bar
working stroke	300 mm	300 mm	300 mm
cylinder dimensions	220 x 160 mm	280 x 200 mm	300 x 210 mm
working speed	5 mm/sec	5 mm/sec	5 mm/sec
motor power	400 V / 50 Hz / 5,5 kW	400 V / 50 Hz / 11 kW	400 V / 50 Hz / 15 kW
dimensions (L x D x H)	2.630 x 1.000 x 2.625 mm	2.630 x 1.000 x 2.350 mm	2.570 x 1.665 x 2.860 mm
weight	1.755 kg	2.350 kg	4.800 kg
	<b>E-WPR 1.570-100</b>	<b>E-WPR 1.570-150</b>	<b>E-WPR 1.900-200</b>
<b>EAN</b>	<b>4260364294736</b>	<b>4260364294743</b>	<b>4260364294750</b>
<b>Item No.</b>	<b>360 3157</b>	<b>360 3158</b>	<b>360 3190</b>

DRILLING

MILLING

TURNING

SAWING

GRINDING

BENDING

CUTTING /  
PRESSING

OTHER  
MACHINES

ACCESSORIES

**E-UWP 1.020-100 / E-UWP 1.020-150**  
**E-UWP 1.520-100 / E-UWP 1.520-150**  
**UNIVERSAL HYDRAULIC WORKSHOP PRESSES**

**PREMIUM-LINE**



PIC: E-UWP 1.020-150

**E - UWP**

- » adjustable table height
- » over and under table with T-slots
- » pressure steplessly adjustable
- » high-performance workshop molding press with additional guide pistons on both sides

**OPTIONAL EQUIPMENT**

- » foot pedal

**Workshop press with T-slots on the table and upper beams for receiving tools, e.g. for the use as a troweling press**

Description	E-UWP 1.020-100	E-UWP 1.020-150	E-UWP 1.520-100	E-UWP 1.520-150
pressure	100 t	150 t	100 t	150 t
max. pressure	263 bar	244 bar	263 bar	244 bar
working stroke	300 mm	300 mm	300 mm	300 mm
max. distance upper/lower table	680 mm	680 mm	610 mm	610 mm
working width	1.020 mm	1.020 mm	1.520 mm	1.520 mm
working speed	5 mm/sec	5 mm/sec	5 mm/sec	5 mm/sec
table size	500 x 1.020 mm	600 x 1.020 mm	500 x 1.520 mm	600 x 1.520 mm
motor power	400 V / 50 Hz / 7,5 kW	400 V / 50 Hz / 11 kW	400 V / 50 Hz / 7,5 kW	400 V / 50 Hz / 11 kW
dimensions (L x D x H)	2.110 x 1.000 x 2.350 mm	2.110 x 1.000 x 2.450 mm	2.630 x 1.000 x 2.350 mm	2.630 x 1.000 x 2.450 mm
weight	1.985 kg	2.450 kg	2.500 kg	3.100 kg
	<b>E-UWP 1.020-100</b>	<b>E-UWP 1.020-150</b>	<b>E-UWP 1.520-100</b>	<b>E-UWP 1.520-150</b>
<b>EAN</b>	<b>4260364294699</b>	<b>4260364294712</b>	<b>4260364294705</b>	<b>4260364294729</b>
<b>Item No.</b>	<b>360 1102</b>	<b>360 1103</b>	<b>360 1152</b>	<b>360 1153</b>



# E-VP 800-80 / E-VP 850-150 / E-VP 900-220 / E-VP 950-300

## UNIVERSAL HYDRAULIC PRESSES

NEW

PREMIUM-LINE



PIC: E-VP 950-300

### E-VP

Extremely robustly constructed motor-driven hydraulic double-column press for shaping, bending or punching sheet metal parts.

- » ram plate and work table with T-slots for clamping the tools
- » easy set-up of the machine with forward and reverse jog operation
- » stroke limitation adjustable via microswitch / stroke travel ram plate
- » automation options on request

Description	E-VP 800-80	E-VP 850-150	E-VP 900-220	E-VP 950-300
pressure	80 t	150 t	220 t	300 t
max. pressure	320 bar	320 bar	320 bar	320 bar
working stroke	250 mm	250 mm	300 mm	300 mm
max. workpiece height	400 mm	400 mm	500 mm	500 mm
working width	800 mm	850 mm	900 mm	950 mm
working speed	3,8 mm/s	3,9 mm/s	3,8 mm/s	2,8 mm/s
table size bottom	750 x 500 mm	750 x 550 mm	800 x 600 mm	850 x 650 mm
table size top	600 x 450 mm	650 x 500 mm	700 x 550 mm	750 x 600 mm
motor power	400 V / 50 Hz / 5,5 kW	400 V / 50 Hz / 7,5 kW	400 V / 50 Hz / 11 kW	400 V / 50 Hz / 11 kW
dimensions (W x D x H)	1.500 x 1.025 x 2.500 mm	1.750 x 1.110 x 2.720 mm	1.875 x 1.095 x 3.045 mm	2.025 x 1.225 x 3.130 mm
weight	2.080 kg	3.250 kg	4.680 kg	6.490 kg
	<b>E-VP 800-80</b>	<b>E-VP 850-150</b>	<b>E-VP 900-220</b>	<b>E-VP 950-300</b>
EAN	4260657650768	4260657650775	4260657650782	4260657650799
Item No.	360 1800	360 1850	360 1900	360 1950

# HAKP 24 / HAKP 48

## HYDRAULIC BENDING PRESSES

**NEW**



PIC: HAKP 24



PIC: HAKP 48

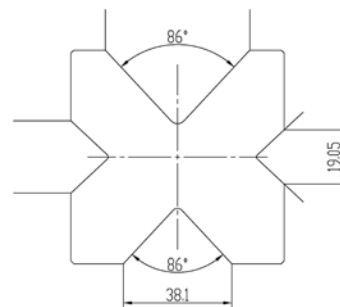

### HAKP 24 / HAKP 48

- » universal robust folding machine
- » ideal for repair purposes
- » samples and / or small quantities
- » with manual back gauge 105-550 mm
- » fold-up upper tool enables edging of sheets to rectangular tubes

The lower tool has different prisms for flexible use.  
Both machines can be used stationary and mobile.



PIC: TOP TOOL  
FOLDED UP

Description	HAKP 24	HAKP 48
pressure	15 t	30 t
max. sheet thickness	4 mm	4 mm
max. bending width	600 mm	1.200 mm
stroke	150 mm	150 mm
motor power	1,5 kW	3 kW
dimensions (L x D x H)	1.200 x 550 x 1.250 mm	1.450 x 660 x 1.450 mm
weight	350 kg	620 kg
	<b>HAKP 24</b>	<b>HAKP 48</b>
<b>EAN</b>	<b>4260364297645</b>	<b>4260364297652</b>
<b>Item No.</b>	<b>227 1024</b>	<b>227 1048</b>

# E-AP 1.020-100 / E-AP 1.020-150 E-AP 1.520-100 / E-AP 1.520-150

## UNIVERSAL HYDRAULIC PRESSBRAKES

**PREMIUM-LINE**



PIC: E-AP 1.020-100



### UNIVERSAL HYDRAULIC PRESSBRAKES

- » vertical travel adjustable via limit switch
- » pressure infinitely variable
- » upper blade not divided
- » lower die with 5-fold prism
- » height-adjustable lower table with T-slots
- » upper die with T-slots

Description	E-AP 1.020-100	E-AP 1.020-150	E-AP 1.520-100	E-AP 1.520-150
pressure	100 t	150 t	100 t	150 t
max. pressure	263 bar	244 bar	263 bar	244 bar
working stroke	300 mm	300 mm	300 mm	300 mm
working width	1.020 mm	1.020 mm	1.520 mm	1.520 mm
working speed	5 mm/sec	5 mm/sec	5 mm/sec	5 mm/sec
table size	500 x 1.020 mm	600 x 1.020 mm	500 x 1.520 mm	600 x 1.520 mm
motor power	400 V / 50 Hz / 7,5 kW	400 V / 50 Hz / 11 kW	400 V / 50 Hz / 7,5 kW	400 V / 50 Hz / 11 kW
dimensions (L x D x H)	2.110 x 1.000 x 2.275 mm	2.110 x 950 x 2.450 mm	2.630 x 1.000 x 2.275 mm	2.630 x 1.000 x 2.450 mm
weight	1.900 kg	2.400 kg	2.500 kg	3.100 kg
	<b>E-AP 1.020-100</b>	<b>E-AP 1.020-150</b>	<b>E-AP 1.520-100</b>	<b>E-AP 1.520-150</b>
<b>EAN</b>	<b>4260364294835</b>	<b>4260364294859</b>	<b>4260364294842</b>	<b>4260364294866</b>
<b>Item No.</b>	<b>360 2102</b>	<b>360 2103</b>	<b>360 2152</b>	<b>360 2153</b>

DRILLING  
MILLING  
TURNING  
SAWING  
GRINDING  
BENDING  
CUTTING / PRESSING  
OTHER MACHINES  
ACCESSORIES

# E-GSP - MODELS

## PRESS BRAKES

**NEW**

**PREMIUM-LINE**



PIC: E-GSP 1.010-30

Press Brakes

### E-GSP - Models

- » sturdy design with welded steel frame
- » punching grid movements via double pistons
- » sensitive, motor-controlled bending angle adjustment
- » universal upper tool
- » PROMECAM-System
- » lower tool with 4 die angles
- » 2 front support arms with T-slots
- » NC-controlled back gauge 500 mm
- » foot pedal

### NOTE

**Applies to all bending presses:**

Formula for calculating the required manpower:

$$F = 1.42 \times L \times R_m \times t^2 / W$$

(L = length of material, R<sub>m</sub> = tensile strength, t = sheet thickness, W = die aperture, F = manpower)

Description	E-GSP 600-30	E-GSP 1.010-30	E-GSP 1.100-40	E-GSP 1.700-60
bending power	30 t	30 t	40 t	60 t
working length	835 mm	1.250 mm	1.500 mm	2.150 mm
max. working depth front	255 mm	255 mm	320 mm	320 mm
max. bending width rear	600 mm	1.010 mm	1.100 mm	1.700 mm
max. working height	265 mm	265 mm	390 mm	390 mm
positioning speed	210 mm/s	210 mm/s	150 mm/s	150 mm/s
working speed	10 mm/s	10 mm/s	10 mm/s	10 mm/s
motor power	3 kW	3 kW	4 kW	5,5 kW
dimensions (W x D x H)	1.350 x 1.375 x 2.135 mm	1.760 x 1.375 x 2.135 mm	1.700 x 1.600 x 2.230 mm	2.350 x 1.600 x 2.230 mm
weight	1.400 kg	1.700 kg	2.650 kg	4.350 kg
	<b>E-GSP 600-30</b>	<b>E-GSP 1.010-30</b>	<b>E-GSP 1.100-40</b>	<b>E-GSP 1.700-60</b>
<b>EAN</b>	4260657650133	4260657650140	4260657650157	4260657650164
<b>Item No.</b>	361 0600	360 0101	361 0110	361 0170

Other machine sizes on request.

# E-GBP - MODELS

## PRESS BRAKES

**PREMIUM-LINE**



### E-GBP - Models

- » with motorised backgauge (can be operated from the front)
- » upper tool holding system "Promecam / Amada"
- » split upper tool, "Amada" system
- » bottom tool universal prism cube made of CroMo 4
- » safety equipment with light barrier

### OPTIONAL ACCESSORIES

- » 2-axis backgauge
- » travel 1.000 mm, instead of 750 mm
- » NC positioning control "ELGO", type P8822 for programming the plunge depth, 200 sets can be stored
- » Y- (bending angle) and position of the backgauge
- » X- (leg length)
- » automatic crowning (WILA-System) built into the table
- » manual adjustment

Description	E-GBP 1.070-40	E-GBP 1.600-40	E-GBP 2.050-60	E-GBP 2.550-90	E-GBP 2.550-200
bending power	40 t	40 t	60 t	90 t	200 t
inside folding width	1.070 mm	1.600 mm	2.050 mm	2.550 mm	2.550 mm
working width outside	1.250 mm	2.100 mm	2.600 mm	3.100 mm	3.100 mm
max. working depth outside	410 mm	410 mm	410 mm	410 mm	410 mm
working speed	10 mm/sec	10 mm/sec	9 mm/sec	10 mm/sec	8 mm/sec
motor power	4 kW	4 kW	5,5 kW	7,5 kW	15 kW
dimensions (W x D x H)	1.250 x 1.270 x 2.150 mm	2.100 x 1.170 x 2.200 mm	2.600 x 1.580 x 2.500 mm	3.100 x 1.580 x 2.520 mm	3.100 x 1.600 x 2.910 mm
weight approx.	2.200 kg	3.100 kg	5.680 kg	6.650 kg	10.500 kg
	<b>E-GBP 1.070-40</b>	<b>E-GBP 1.600-40</b>	<b>E-GBP 2.050-60</b>	<b>E-GBP 2.550-90</b>	<b>E-GBP 2.550-200</b>
<b>EAN</b>	4260657650003	4260657650010	4260657650027	4260657650034	4260657650041
<b>Item No.</b>	310 0107	310 0160	310 0205	310 0255	310 0252

Description	E-GBP 2.550-300	E-GBP 3.250-160	E-GBP 3.250-240	E-GBP 3.550-200	E-GBP 3.550-300
bending power	300 t	160 t	240 t	200 t	300 t
inside folding width	2.550 mm	3.250 mm	3.250 mm	3.550 mm	3.550 mm
working width outside	3.100 mm	3.700 mm	3.700 mm	4.100 mm	4.100 mm
max. working depth outside	500 mm	410 mm	410 mm	410 mm	500 mm
working speed	9 mm/sec	8 mm/sec	8 mm/sec	8 mm/sec	9 mm/sec
motor power	22 kW	11 kW	18,5 kW	15 kW	22 kW
dimensions (W x D x H)	3.100 x 1.815 x 3.090 mm	3.700 x 1.600 x 2.770 mm	3.700 x 1.610 x 2.950 mm	4.100 x 1.600 x 2.750 mm	4.100 x 1.920 x 3.100 mm
weight approx.	16.000 kg	11.200 kg	14.000 kg	14.500 kg	21.000 kg
	<b>E-GBP 2.550-300</b>	<b>E-GBP 3.250-160</b>	<b>E-GBP 3.250-240</b>	<b>E-GBP 3.550-200</b>	<b>E-GBP 3.550-300</b>
<b>EAN</b>	4260657650058	4260657650065	4260657650072	4260657650089	4260657650096
<b>Item No.</b>	310 0253	310 0325	310 0322	310 0355	310 0353

Other machine sizes on request.

DRILLING

MILLING

TURNING

SAWING

GRINDING

BENDING

CUTTING / PRESSING

OTHER MACHINES

ACCESSORIES



# E-GBP CNC - MODELS

## PRESS BRAKES

**PREMIUM-LINE**



PIC: E-GBP 2.550-120 CNC

Heavy series for bending and edging sheet metal etc.

**For technical data check page 283/284.**

Powerful, universal press brakes for bending sheet metal round or sharp-edged to various angles. Different edging and inserting tools are available.

The stable machine frame made of high-quality steel with a large stand projection makes this press brake a cost-effective universal bending machine. Adjustable hydraulic pressure, mechanical parallelism as well as adjustable travel limiters ensure high repeatability.

The standard machine control system has been specially developed for sheet metal bending applications and fulfills all requirements for user-friendly bending control.

### Standard

- » interchangeable lower and upper tools
- » rear stop 600 mm gauge with digital display, resolution 0,1 mm
- » triple foot pedal
- » CNC synchronous control Delem DA-52s for max. 4 axes plus motorised crowning
- » 6.4" colour screen
- » USB interface
- » hydraulic elements from Hoerbiger or Bosch Rexroth
- » CE laser safety device Fiessler "AKAS II
- » front support arms on linear rail
- » backgauge X-axis 650 mm with servo motor
- » upper and lower tool clamping as well as upper and lower tool type AMADA
- » LED work area lighting

Optional accessories  
On request

**Further machine sizes on request.**

# E-GBP CNC - MODELS

## PRESS BRAKES

**PREMIUM-LINE**



PIC: E-GBP 5.100-240 CNC

Description	E-GBP 1.070-40 CNC	E-GBP 1.600-60 CNC	E-GBP 2.050-90 CNC	E-GBP 2.550-90 CNC	E-GBP 2.550-120 CNC
pressure	40 t	60 t	90 t	90 t	120 t
press brake width	800 mm	800 mm	860 mm	880 mm	880 mm
working speed	10 mm/s	10 mm/s	10 mm/s	10 mm/s	10 mm/s
working width inside	1.070 mm	1.600 mm	2.050 mm	2.550 mm	2.550 mm
total width	1.250 mm	2.100 mm	2.600 mm	3.100 mm	3.100 mm
motor	400 V / 50 Hz / 4 kW	400 V / 50 Hz / 5,5 kW	400 V / 50 Hz / 7,5 kW	400 V / 50 Hz / 7,5 kW	400 V / 50 Hz / 11 kW
dimensions (L x D x H)	1.250 x 1.470 x 2.250 mm	2.100 x 1.580 x 2.542 mm	2.600 x 1.580 x 2.605 mm	3.100 x 1.590 x 2.605 mm	3.100 x 1.590 x 2.905 mm
weight	3.300 kg	5.400 kg	7.100 kg	7.900 kg	8.400 kg
	<b>E-GBP 1.070-40 CNC</b>	<b>E-GBP 1.600-60 CNC</b>	<b>E-GBP 2.050-90 CNC</b>	<b>E-GBP 2.550-90 CNC</b>	<b>E-GBP 2.550-120 CNC</b>
<b>EAN</b>	<b>4260364296853</b>	<b>4260364296860</b>	<b>4260364296877</b>	<b>4260364298833</b>	<b>4260364296884</b>
<b>Item No.</b>	<b>310 2107</b>	<b>310 2160</b>	<b>310 2205</b>	<b>310 2255</b>	<b>310 2256</b>

Description	E-GBP 2.550-160 CNC	E-GBP 2.550-200 CNC	E-GBP 2.550-240 CNC	E-GBP 2.550-300 CNC	E-GBP 3.550-160 CNC
pressure	160 t	200 t	240 t	240 t	160 t
press brake width	880 mm	880 mm	880 mm	905 mm	880 mm
working speed	10 mm/s	10 mm/s	10 mm/s	8 mm/s	10 mm/s
working width inside	2.550 mm	2.550 mm	2.550 mm	2.550 mm	3.550 mm
total width	3.100 mm	3.100 mm	3.100 mm	3.100 mm	4.100 mm
motor	400 V / 50 Hz / 15 kW	400 V / 50 Hz / 18,5 kW	400 V / 50 Hz / 22 kW	400 V / 50 Hz / 22 kW	400 V / 50 Hz / 15 kW
dimensions (L x D x H)	3.100 x 1.600 x 2.905 mm	3.100 x 1.600 x 2.905 mm	3.100 x 1.610 x 2.905 mm	3.100 x 1.815 x 3.150 mm	4.100 x 1.600 x 2.905 mm
weight	9.700 kg	10.000 kg	11.000 kg	15.000 kg	12.000 kg
	<b>E-GBP 2.550-160 CNC</b>	<b>E-GBP 2.550-200 CNC</b>	<b>E-GBP 2.550-240 CNC</b>	<b>E-GBP 2.550-300 CNC</b>	<b>E-GBP 3.250-160 CNC</b>
<b>EAN</b>	<b>4260364298840</b>	<b>4260364298857</b>	<b>4260364298864</b>	<b>4260364299700</b>	<b>4260364298871</b>
<b>Item No.</b>	<b>310 2257</b>	<b>310 2558</b>	<b>310 2559</b>	<b>310 2560</b>	<b>310 2355</b>

Further machine sizes on the following page.

DRILLING  
MILLING  
TURNING  
SAWING  
GRINDING  
BENDING  
CUTTING / PRESSING  
OTHER MACHINES  
ACCESSORIES

# E-GBP CNC - MODELS

## PRESS BRAKES

Description	E-GBP 3.550-200 CNC	E-GBP 3.550-240 CNC	E-GBP 3.550-300 CNC	E-GBP 3.550-440 CNC	E-GBP 5.100-240 CNC
pressure	200 t	240 t	300 t	440 t	240 t
press brake width	880 mm	880 mm	980 mm	955 mm	1.100 mm
working speed	10 mm/s	10 mm/s	8 mm/s	8 mm/s	10 mm/s
working width inside	3.550 mm	3.550 mm	3.550 mm	3.550 mm	5.100 mm
total width	4.100 mm	4.100 mm	4.100 mm	4.100 mm	6.100 mm
motor	400 V / 50 Hz / 18,5 kW	400 V / 50 Hz / 22 kW	400 V / 50 Hz / 22 kW	400 V / 50 Hz / 30 kW	400 V / 50 Hz / 22 kW
dimensions (L x D x H)	4.100 x 1.600 x 2.905 mm	4.100 x 1.610 x 2.905 mm	4.100 x 1.820 x 3.200 mm	4.100 x 2.235 x 3.350 mm	6.100 x 1.960 x 3.000 mm
weight	12.500 kg	14.000 kg	18.500 kg	26.000 kg	25.000 kg
	E-GBP 3.550-200 CNC	E-GBP 3.550-240 CNC	E-GBP 3.550-300 CNC	E-GBP 3.550-440 CNC	E-GBP 5.100-240 CNC
EAN	4260364298888	4260364296914	4260364298895	4260364298901	4260364298918
Item No.	310 2356	310 2357	310 2358	310 2359	310 2511

Description	E-GBP 5.100-300 CNC	E-GBP 5.100-380 CNC	E-GBP 5.100-440 CNC	E-GBP 5.100-600 CNC	E-GBP 5.100-800 CNC
pressure	300 t	380 t	440 t	600 t	800 t
press brake width	1.115 mm	1.100 mm	1.100 mm	1.050 mm	1.050 mm
working speed	8 mm/s	8 mm/s	8 mm/s	7 mm/s	6 mm/s
working width inside	5.100 mm	5.100 mm	5.100 mm	5.100 mm	5.100 mm
total width	6.100 mm	6.100 mm	6.100 mm	6.100 mm	6.100 mm
motor	400 V / 50 Hz / 22 kW	400 V / 50 Hz / 30 kW	400 V / 50 Hz / 30 kW	400 V / 50 Hz / 45 kW	400 V / 50 Hz / 45 kW
dimensions (L x D x H)	6.100 x 2.060 x 3.280 mm	6.100 x 2.210 x 3.255 mm	6.100 x 2.250 x 3.700 mm	6.100 x 2.400 x 4.100 mm	6.100 x 2.800 x 4.750 mm
weight	30.000 kg	35.000 kg	39.000 kg	55.000 kg	70.000 kg
	E-GBP 5.100-300 CNC	E-GBP 5.100-380 CNC	E-GBP 5.100-440 CNC	E-GBP 5.100-600 CNC	E-GBP 5.100-800 CNC
EAN	4260364298925	4260364298932	4260364298949	4260364298956	4260364298963
Item No.	310 2512	310 2513	310 2514	310 2515	310 2516

Press Brakes



PIC: WORKING AREA PRESS BRAKES  
(E-GBP 2.550-120 CNC)  
WITH SPECIAL ACCESSORIES  
QUICK-CHANGE HOLDERS AND  
SHEET LIFTING HOLDER

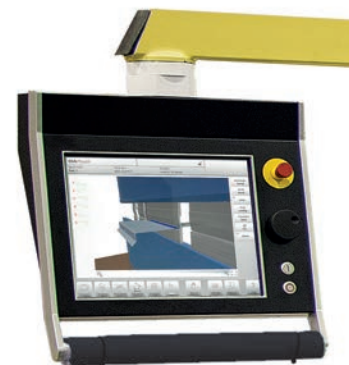

PIC: MONITOR FOR  
PRESS BRAKES



# Mobile and stationary devices to facilitate welding work

# SP 300 SM / SP 30 M / SP 300 M SP 220 / SP 350 / SP 500

## WELDING POSITIONER



PIC: SP 300 SM



PIC: SP 30 M



PIC: SP 300 M



PIC: SP 350



PIC: SP 500

Welding Positioner

### SP 300 SM / SP 30 M / SP 300 M / SP 220 / SP 350 / SP 500

When welding, the position and accessibility of the part to be welded is important. Welding positioners and welding turntables are a great help here. Robust drive technology and stable construction ensure the positioning of the workpiece. Different sizes and designs are available. The SP 300 M model is designed for welding large-format frames.

Description	SP 300 SM	SP 30 M	SP 300 M	SP 220	SP 350	SP 500
max. horizontal load	300 kg	30 kg	300 kg	220 kg	350 kg	500 kg
max. vertical load	150 kg	20 kg	150 kg	100 kg	120 kg	250 kg
table height	710 / 760 / 810 / 860 mm	370 mm	1.020 mm	450 mm	480 mm	660 mm
table diameter	-	-	-	330 mm	330 mm	550 mm
table speeds	-	-	-	0-5 min <sup>-1</sup>	0 - 5 min <sup>-1</sup>	0 - 5 min <sup>-1</sup>
table drive	manual	manual	manual	0,125 kW	0,125 kW	0,40 kW
tilt angle	22,5° / 45° / 90°	-	-	0 - 135°	0 - 135°	-45° to +90°
angle adjustment	-	-	-	manual	manual	electrical
weight	86 kg	40 kg	135 kg	34 kg	38 kg	220 kg

	SP 300 SM	SP 30 M	SP 300 M	SP 220	SP 350	SP 500
EAN	4260364297584	4260364297591	4260364297607	4260364297614	4260364297621	4260364297638
Item No.	229 0001	229 0002	229 0003	229 1001	229 1002	229 1003



# WS 1.100-900

## WELDING WORKSTATION

**NEW**



### WS 1.100-900

Compact welding workstation in sturdy sheet steel construction with extraction in the base and with 3-stage air filter. Extraction through table downwards / air pressure requirement 4-6 bar.

In addition, there is a connection option for an external extraction system.

Description	WS 1.100-900
table size	1.168 x 982 mm
table height	985 mm
usable table load capacity	10%: 87 kg 20%: 174 kg 30%: 261 kg 40%: 348 kg 50%: 435 kg 60%: 522 kg 70%: 609 kg 80%: 700 kg
air requirement	4.1 - 6.2 bar
motor	400 V / 50 Hz / 1,5 kW
dimensions (L x D x H)	1.460 x 1.070 x 1.980 mm
weight	355 kg
<b>EAN</b>	<b>4260657650805</b>
<b>Item No.</b>	<b>229 1100</b>

# AC 60 / AC 100

## ANGLE MACHINE VICES



### AC 60 / AC 100

#### IDEAL FOR WELDING

- » for welding of different material thickness in the right angle
- » different thick work parts can be clamped in the right angle by the pivoting axis

Description	AC 60	AC 100
jaw width	60 mm	100 mm
jaw open	60 mm	105 mm
jaw height	35 mm	60 mm
dimensions (L x D x H)	200 x 200 x 70 mm	300 x 300 x 100 mm
weight	4,8 kg	11 kg
<b>EAN</b>	<b>4260364292879</b>	<b>4260364292886</b>
<b>Item No.</b>	<b>520 0006</b>	<b>520 0010</b>

# KA-M / KA 4 / KA 6 / KA 400

## EDGE MILLING MACHINES

**NEW**



PIC: KA 4

### KA-M / KA 4 / KA 6 / KA 400

Chamfering machine to produce burr-free edges with insert milling cutter.

KA-M is a portable model for chamfering large-sized components. KA-400 works at 6,000 min<sup>-1</sup>, not for delicate components, but very fast. With an optimal form cutter, radius chamfers can also be achieved (1 - 4 mm width).

### OPTIONAL ACCESSORIES

» stand

Description	KA-M	KA 4	KA 6	KA 400
chamfer width	0 - 6,0 mm	0 - 4,0 mm	0 - 6,0 mm	0 - 6,0 mm
chamfer angle	15 - 45°	15 - 45°	15 - 45°	15 - 45°
motor speed	2.800 min <sup>-1</sup>	2.800 min <sup>-1</sup>	2.800 min <sup>-1</sup>	6.000 min <sup>-1</sup>
motor power	230 V / 50 Hz / 0,75 kW	230 V / 50 Hz / 0,37 kW	230 V / 50 Hz / 1,1 kW	400 V / 50 Hz / 0,75 kW
dimensions (L x D x H)	200 x 180 x 320 mm	480 x 380 x 440 mm	550 x 440 x 540 mm	500 x 300 x 380 mm
weight	7,5 kg	28 kg	66 kg	42 kg
	<b>KA-M</b>	<b>KA 4</b>	<b>KA 6</b>	<b>KA 400</b>
<b>EAN</b>	<b>4260657651710</b>	<b>4260657651727</b>	<b>4260657651734</b>	<b>4260657651741</b>
<b>Item No.</b>	<b>225 0060</b>	<b>225 0040</b>	<b>225 0160</b>	<b>225 0260</b>

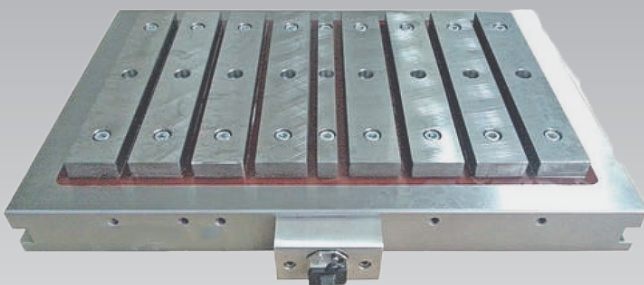
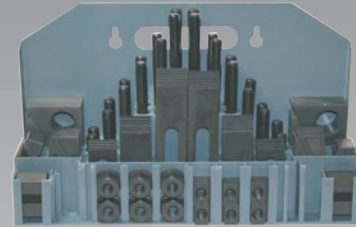
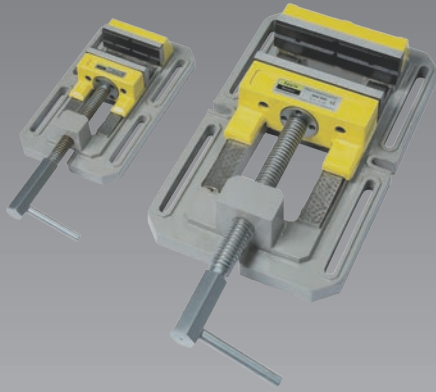

# Accessories

## MSE 75 / MSE 100 / MSE 125 / MSE 150

### MACHINE VICES



PIC: MSE 75 / MSE 100

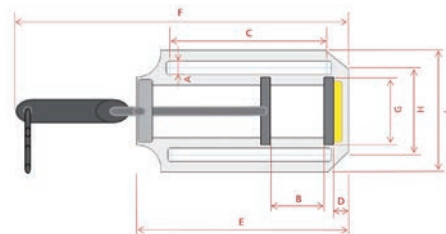

Description	MSE 75	MSE 100	MSE 125	MSE 150
A	12,5	12,5	12,5	14,5
B	55	90	110	130
C	55	74	80	100
D	30	46	46	56
E	126	165	186	222
F	270	350	400	455
G	75	100	125	150
H	100	130	150	170
I	130	165	182	208
weight	1,7 kg	3,2 kg	4,5 kg	6,2 kg
<b>EAN</b>	<b>4260364292664</b>	<b>4260364292671</b>	<b>4260364292688</b>	<b>4260364292695</b>
<b>Item No.</b>	<b>121 0075</b>	<b>121 0100</b>	<b>121 0125</b>	<b>121 0150</b>

#### MACHINE VICES WITH PRISMS

- » easy vices serie in high quality
- » smooth running with exact jaw guides, also at a high axial load
- » rolled trapezoidal spindle
- » smooth running
- » different possibilities of positioning long holes in the foot of the vice

## MSI 100 / MSI 140 / MSI 200

### MACHINE VICES



PIC: MSI 100 / MSI 200

Description	MSI 100	MSI 140	MSI 200
A	350 - 460 mm	455 - 610 mm	578 - 788 mm
B	88 mm	105 mm	163 mm
C	110 mm	150 mm	200 mm
D	12 mm	14 mm	16 mm
E	19 mm	23 mm	28 mm
F	100 mm	140 mm	200 mm
G	136 mm	189 mm	250 mm
H	170 mm	230 mm	290 mm
I	12 mm	14 mm	14 mm
J	216 mm	290 mm	406 mm
weight	8,7 kg	18 kg	35 kg
<b>EAN</b>	<b>4260364292701</b>	<b>4260364292718</b>	<b>4260364292725</b>
<b>Item No.</b>	<b>121 2100</b>	<b>121 2140</b>	<b>121 2200</b>

#### MACHINE VICE

- » drill vices in industrial quality
- » manually trimmed bearing surfaces
- » high quality cast frame
- » stable and moveable jaw-thereby no tilting
- » replaceable prismatic jaws
- » different possibilities of positioning long holes in the foot of the vice

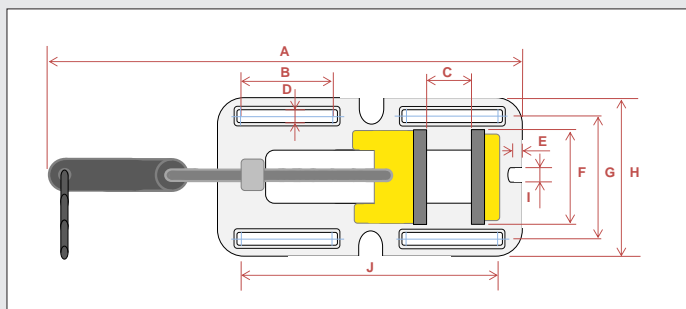

## MS 100

### MACHINE VICE

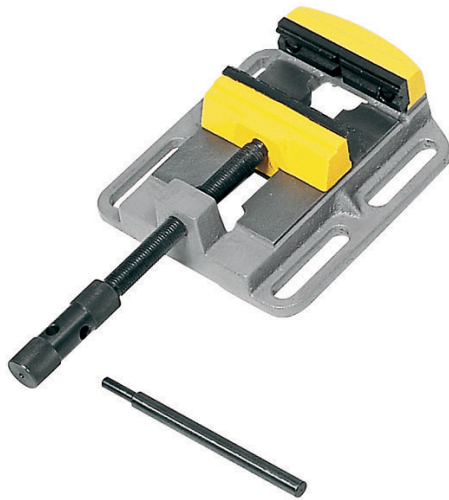

#### MS 100

- » changeable prismatic jaws
- » supplied with pin for powerful clamping
- » smooth running with exact jaw guides, also at a high axial load
- » multiple mounting and clamping facilities through slots in base

Description	MS 100
jaw width	100 mm
jaw open	105 mm
weight	4 kg
<b>EAN</b>	<b>4260364292633</b>
<b>Item No.</b>	<b>120 0100</b>

## MS 125

### MACHINE VICE



#### MS 125

- » changeable prismatic jaws
- » supplied with pin for powerful clamping
- » smooth running with exact jaw guides, also at a high axial load
- » multiple mounting and clamping facilities through slots in base

Description	MS 125
jaw width	125 mm
jaw open	125 mm
weight	10 kg
<b>EAN</b>	<b>4260364292640</b>
<b>Item No.</b>	<b>120 0125</b>



**MSS 135**  
QUICK ACTION VICE



**MSS 135**  
IDEAL FOR SERIAL PRODUCTION;  
TENSIONS VIA HANDLEBAR ABOUT  
ECCENTRIC LEVER  
» changeable prismatic jaws  
» quick release lock via the eccentric lever  
» supplied with pin for powerful clamping  
» multiple mounting and clamping facilities through  
slots in base

Description	MSS 135
jaw width	135 mm
jaw open	145 mm
weight	15 kg
<b>EAN</b>	<b>4260364292749</b>
<b>Item No.</b>	<b>120 1135</b>

**MSS 180**  
QUICK ACTION VICE



**MSS 180**  
» changeable prismatic jaws  
» supplied with pin for powerful clamping  
» smooth running with exact jaw guides, also at a high  
axial load  
» multiple mounting and clamping facilities through  
slots in base

Description	MSS 180
jaw width	180 mm
jaw open	260 mm
weight	40 kg
<b>EAN</b>	<b>4260364292756</b>
<b>Item No.</b>	<b>120 1180</b>

## FS 16-100

### MILLING VICE



#### FS 16-100

- » solid construction, swivel base is graduated through 360°
- » made of high-grade cast iron
- » clear readable scales
- » hardened and ground bearing surface
- » changeable, hardened and ground clamping jaws
- » absolutely solid fit of the workpart during treatment

Description	FS 16-100
jaw width	100 mm
jaw open	90 mm
jaw height	33 mm
dimensions (L x W x H)	360 x 230 x 120 mm
weight	16 kg
<b>EAN</b>	<b>4260364292763</b>
<b>Item No.</b>	<b>520 3050</b>

## FS 16-200

### MILLING VICE



#### FS 16-200

- » solid construction, swivel base is graduated through 360°
- » made of high-grade cast iron
- » clear readable scales
- » hardened and ground bearing surface
- » changeable, hardened and ground clamping jaws
- » absolutely solid fit of the workpart during treatment

Description	FS 16-200
jaw width	200 mm
jaw open	220 mm
jaw height	50 mm
dimensions (L x W x H)	550 x 350 x 180 mm
weight	54 kg
<b>EAN</b>	<b>4260364292787</b>
<b>Item No.</b>	<b>520 3070</b>

## FMS 100 / FMS 125 / FMS 150

### MILLING VICES

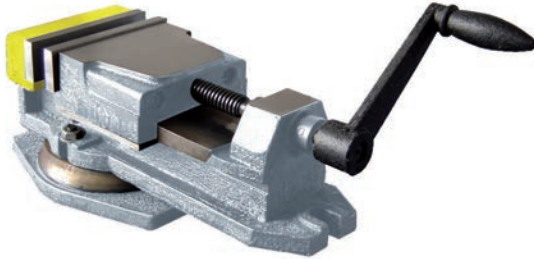

PIC: FMS 100

Description	FMS 100	FMS 125	FMS 150
E	100	125	150
A	267	345	421
B	106	128	160
H	75	98	105
R	62	85	114
S	395	370	462
a	160	208	245
s	114	150	175
h1	30	37	40
h2	25	30	40
g1	13	12	16
g2	13	13	13
weight	11 kg	17 kg	28 kg
<b>EAN</b>	<b>4260364292794</b>	<b>4260364292800</b>	<b>4260364292817</b>
<b>Item No.</b>	<b>521 0100</b>	<b>521 0125</b>	<b>521 0150</b>

#### HIGH-PRECISION MILLING VICE

- » solid construction for drilling, milling, grinding
- » hardened and ground bearing surface
- » changeable, hardened and ground clamping jaws
- » made of high-grade cast iron
- » swivel base is graduated through 360°

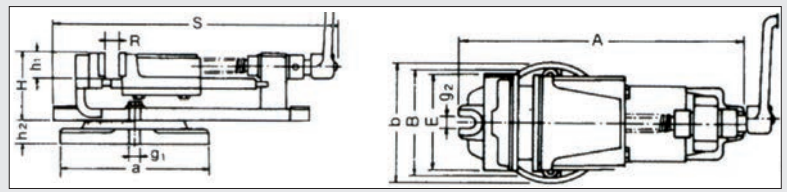

## FMSN 100 / FMSN 125 / FMSN 150

### MILLING VICES

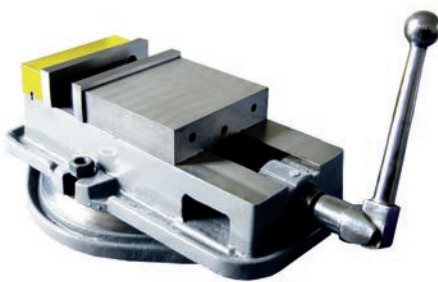

PIC: FMSN 100

Description	FMSN 100	FMSN 125	FMSN 150
A	100	125	150
B	31	33	46
C	101	108	146
a	219	369	425
b	165	193	209
c	88	96	111
d	247	254	298
e	31	34	41
f	6	7	9
weight	18,8 kg	29 kg	36 kg
<b>EAN</b>	<b>4260364292824</b>	<b>4260364292831</b>	<b>4260364292848</b>
<b>Item No.</b>	<b>521 1100</b>	<b>521 1125</b>	<b>521 1150</b>

#### HIGH-PRECISION MILLING VICE

- » secure straining of the workpart
- » made of high-grade cast iron
- » hardened and ground bearing surface
- » changeable, hardened and ground clamping jaws
- » clamping jaws straining outwards by tramming
- » secured spindle
- » swivel base is graduated through 360°

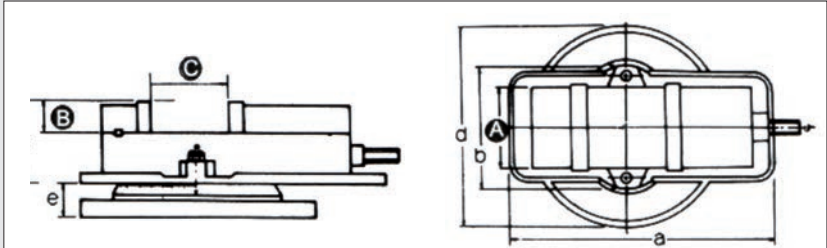

## UPS 100

### UNIVERSAL MACHINE VICE



#### UPS 100

##### with 4 clamping surfaces

- » precision vice with ground clamping surfaces
- » robust and solid construction
- » vice made of high quality cast iron
- » horizontal rotation of the jaws from 0° to 90° in each direction.
- » turntable rotatable by 360°
- » ideal for clamping round material horizontal and vertical

Description	UPS 100
jaw width	100 mm
jaw open	100 mm
jaw height	37 mm
dimensions (L x D x H)	355 x 162 x 118 mm
weight	22 kg
<b>EAN</b>	<b>4260364296938</b>
<b>Item No.</b>	<b>520 4010</b>

## FS 3D-100

### 3D-MACHINE VICE



#### FS 3D-100

- » stable and solid construction
- » 3-dimensional: rotatable, swivelling and tiltable
- » with rotary plate
- » changeable, hardened and ground clamping jaws
- » clear readable scales

Description	FS 3D-100
jaw width	100 mm
jaw open	105 mm
jaw height	40 mm
dimensions (L x D x H)	420 x 280 x 190 mm
weight	32 kg
<b>EAN</b>	<b>4260364292862</b>
<b>Item No.</b>	<b>520 3310</b>

## MACHINE LIGHTS (LED)

### FIX / FLEXIBLE



FIX



FLEXIBLE

#### FIX / FLEXIBLE LED MACHINE LIGHT

- » with magnetic base or with mounting plate on request
- » integrated transformer
- » 24 V halogen

Description	Fixed light	Flexible light
Supply voltage	24 V	24 V
<b>EAN</b>	<b>4260364293012</b>	<b>4260364293029</b>
<b>Item No.</b>	<b>535 5030</b>	<b>535 5010</b>

120 x 400 mm / 180 x 500 mm  
180 x 700 mm / 210 x 730 mm

CROSS TABLES

- » dovetail slideway adjustable
- » channeling for cooling liquid drain
- » adjustable fine scale of hand wheels with 0,05 mm disposition

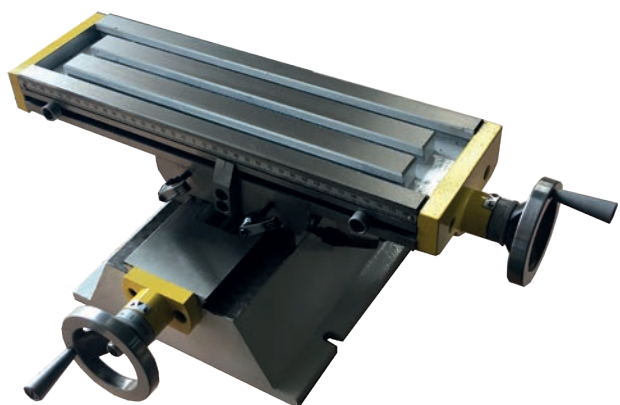

Description	120 x 400	180 x 500	180 x 700	210 x 730
length	506 mm	748 mm	945 mm	1.065 mm
depth	400 mm	483 mm	483 mm	555 mm
height	140 mm	148 mm	169 mm	200 mm
T-slot size	10 mm	12 mm	12 mm	14 mm
table (W x D)	120 x 400 mm	180 x 500 mm	180 x 700 mm	210 x 730 mm
table load max.	70 kg	120 kg	120 kg	150 kg
foot width	220 mm	274 mm	274 mm	280 mm
foot length	280 mm	340 mm	340 mm	362 mm
travelling X-axis	220 mm	287 mm	480 mm	480 mm
travelling Y-axis	165 mm	167 mm	170 mm	210 mm
distance mounting hole X-axis	210 mm	260 mm	250 mm	270 mm
distance mounting hole Y-axis	160 mm	220 mm	220 mm	300 mm
weight	25 kg	45 kg	52 kg	73 kg
EAN	4260364292893	4260364292909	4260364292916	4260364292923
Item No.	520 2120	520 2185	520 2187	520 2210

RTHV 150 / RTHV 200

ROTARY TABLES

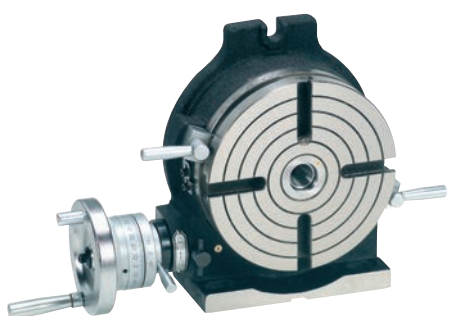

- » totally ground finish provides high precision and smooth rotation
- » worm gear ratio is 90:1
- » scale dividing through scale adjustable nonius
- » circumference of the table is scaled 360°
- » table plate can be mounted by two clamps
- » table plate made of high quality Meehanite cast iron
- » 1 Dial = 4° adjustment

Description	RTHV 150	RTHV 200
table diameter	150 mm	200 mm
centre height	100 mm	135 mm
table height	80 mm	105 mm
centre sleeve	MT 2	MT 3
slot size	10 mm	12 mm
dimensions (L x D x H)	330 x 200 x 90 mm	400 x 275 x 110 mm
weight	14 kg	26 kg
EAN	4260364292930	4260364292947
Item No.	535 2150	535 2200

UNIVERSAL HORIZONTAL AND VERTICAL ROTARY TABLES



# E - MSP

## MAGNETIC CLAMPING PLATES

PREMIUM-LINE

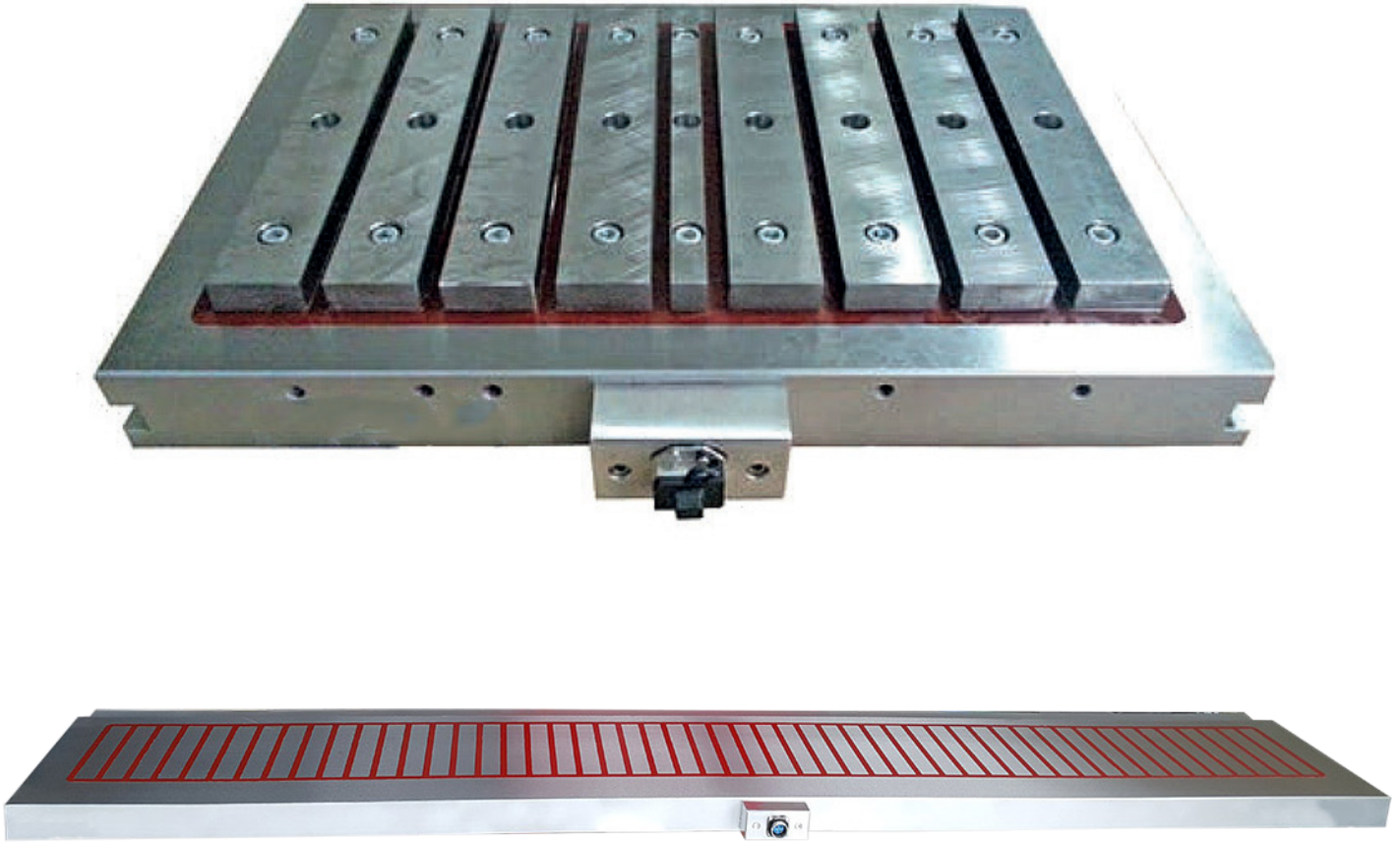

Powerful permanent electromagnetic clamping plates for use on surface grinding machines, milling machines, presses, injection moulding machines and special machines.

With a holding force of 16 kg/cm<sup>2</sup> and pole pitch of 15 mm, these magnetic clamping plates are also suitable for higher clamping force requirements.

Power supply via electronic control 230 Volt.

### TECHNICAL DATA

Description	E-MSP 3535	E-MSP 5043	E-MSP 5636	E-MSP 6050	E-MSP 6843	E-MSP 8050
clamping surface mm	580 x 340 mm	500 x 430 mm	680 x 430 mm	600 x 500 mm	800 x 500 mm	1000 x 500 mm
holding force max.	16 kg/cm <sup>2</sup>	16 kg/cm <sup>2</sup>	16 kg/cm <sup>2</sup>	16 kg/cm <sup>2</sup>	16 kg/cm <sup>2</sup>	16 kg/cm <sup>2</sup>
<b>EAN</b>	<b>4260364296945</b>	<b>4260364296952</b>	<b>4260364296969</b>	<b>4260364296976</b>	<b>4260364296983</b>	<b>4260364296990</b>
<b>Item No.</b>	<b>630 3535</b>	<b>630 5043</b>	<b>630 5636</b>	<b>630 6050</b>	<b>630 6843</b>	<b>630 8050</b>

DRILLING

MILLING

TURNING

SAWING

GRINDING

BENDING

CUTTING /  
PRESSING

OTHER  
MACHINES

ACCESSORIES

# QUICK ACTION DRILL CHUCK / DRILL SET / MORSE TAPER DRILL SET



QUICK ACTION DRILL CHUCK

**QUICK-ACTION DRILL CHUCK**  
**RÖHM B 16 1-13 MM, RÖHM B 16 3-16 MM, B 16 1-16 MM**  
 » quality keyless drill chuck  
 » universal service



Description	RÖHM 1-13 mm	RÖHM 3-16 mm	1-16 mm
EAN	4260364293128	4260364293135	4260657651819
Item No.	510 3013	510 3016	510 0016



THREADING ATTACHMENT

**THREADING ATTACHMENT M3-M12**  
 » with taper MT 2  
 » torque adjustable M3 - M12  
 » integrated rapid reverse  
 » quick action drill chuck for thread drill

Description	Threading Attachment
EAN	4260364293142
Item No.	510 3212



HSS DRILL SET

**HSS DRILL SET**  
 25 PCS. 1-13 MM ZYLINDRIC  
 » HSS drill  
 » for steel, light metals, plastic and wood  
 » 0,5 mm increasing from 1-13 mm  
 » in practical sheet box

Description	HSS Drill Set
EAN	4260364293159
Item No.	510 9013



MORSE TAPER DRILL CASE 1

**MORSE TAPER DRILL CASE 1**  
 14,5 / 15 / 16 / 17 / 18 /  
 19 / 20 / 21 / 22 / 23 MM  
 » HSS spiral drills  
 » 10 pcs.  
 » several drills equipped with MT 2

Description	Morse Taper Drill Case 1
EAN	4260364293166
Item No.	510 1423



MORSE TAPER DRILL CASE 2

**MORSE TAPER DRILL CASE 2**  
 14,5 / 16 / 18 / 20 / 22 /  
 24 / 26 / 28 / 30 MM  
 » HSS spiral drills  
 » 9 pcs.  
 » 14,5 - 22 mm drills equipped with MT 2  
 » 24 - 30 mm drills equipped with MT 3

Description	Morse Taper Drill Case 2
EAN	4260364293173
Item No.	510 1430

## THE FLOW HOLE MOULDING PROCESS

The flow hole moulding process enables drill holes or thread core holes to be drilled very quickly in thin-walled metallic material without the formation of cutting chips. Specially shaped "flow drills" and higher spindle speeds generate friction that causes the workpiece to melt at this point, resulting in a round hole. The excess material "flows" to the edge of the hole. In the case of thin material, this process produces a reinforcement (bead) around the bore, i.e. longer threads can be produced. This technique can be used for material thicknesses up to approx. 12 mm. Drillings are possible up to 4 times the original material thickness.



The bead around the hole is created by the standard flow drill on the top and bottom of the sheet material. This is not always desired, which is why there is also the "Cut" model, where the bead is removed from the top of the sheet during the process.

**In addition, both versions are available in longer versions.  
Further information on request; We are also available for task-specific counselling.**

Standard Thread	Flow hole forms	Flow former model Cut
	Item number	Item number
2,0 - 2,9	511 0002	511 1002
3,0 - 3,9	511 0003	511 1003
4,0 - 4,9	511 0004	511 1004
5,0 - 5,9	511 0005	511 1005
6,0 - 6,9	511 0006	511 1006
7,0 - 7,9	511 0007	511 1017
8,0 - 8,9	511 0008	511 1018
9,0 - 9,9	511 0009	511 1019
10,0 - 10,9	511 0010	511 1010
11,0 - 11,9	511 0011	511 1011
12,0 - 12,9	511 0012	511 1012
13,0 - 13,9	511 0013	511 1013
14,0 - 14,9	511 0014	511 1014
15,0 - 15,9	511 0015	511 1015
16,0 - 16,9	511 0016	511 1016
17,0 - 17,9	511 0017	511 1027
18,0 - 18,9	511 0018	511 1028
19,0 - 19,9	511 0019	511 1029
20,0 - 20,9	511 0020	511 1020
21,0 - 21,9	511 0021	511 1021
22,0 - 22,9	511 0022	511 1022
23,0 - 23,9	511 0023	511 1023
24,0 - 24,9	511 0024	511 1024
25,0 - 25,4	511 0025	511 1025



PIC:  
STARTER SET  
FOR FLOW MOULD M10

Description	Flow Hole Moulding
EAN	4260364297041
Item No.	511 0001

**The flow hole moulding process is force intensive and requires machines with a powerful motor and a high driving speed.  
Price on request; We will be happy to advise you.**

# MORSE TAPERS / REDUCING SLEEVES EXTENSION SLEEVES / LIFE CENTER

## MORSE TAPER / SLEEVES / LIFE CENTER

### REDUCING SLEEVES



Description	EAN	Item No.
Reducing Sleeves MT 2 to MT 1	4260364293227	510 1021
Reducing Sleeves MT 3 to MT 2	4260364293234	510 1032
Reducing Sleeves MT 4 to MT 2	4260364293241	510 1042
Reducing Sleeves MT 4 to MT 3	4260364293258	510 1043
Reducing Sleeves MT 5 to MT 2	4260364293265	510 1052
Reducing Sleeves MT 5 to MT 3	4260364293272	510 1053
Reducing Sleeves MT 5 to MT 4	4260364293289	510 1054

### EXTENSIONS SLEEVES



Description	EAN	Item No.
Extension Sleeves MT 2 to MT 3	4260364293296	510 1123
Extension Sleeves MT 3 to MT 4	4260364293302	510 1134

### MORSE TAPERS



Description	EAN	Item No.
Morse Taper MT 2 B16	4260364293180	510 0216
Morse Taper MT 3 B16	4260364293197	510 0316
Morse Taper MT 4 B16	4260364293203	510 0416
Morse Taper MT 5 B16	4260364293210	510 0516

### LIFE CENTER MT 2/3/4



Description	EAN	Item No.
Life Center MT 2	4260364293319	510 0517
Life Center MT 3	4260364293326	510 0518
Life Center MT 4	4260364293333	510 0519

### REVOLVING CENTER WITH REPLACEMENT LATHE CENTERS



- » MT 2
- » 7 replaceable lathe centers
- » precision needle roller bearings ensures
- » supplied in a solid wooden box

Description	EAN	Item No.
revolving center with replacement lathe centers	4260364293340	510 0620

# SPW 10 / SPW 12 / SPW 14

## CLAMP KIT



### CLAMP KIT

SPW 10 52 - PCS.

SPW 12 58 - PCS.

SPW 14 52 - PCS.

- » handy wall unit
- » metric threads
- » drawbar M 10 / M 12 / M 14
- » 24 pcs. tightening bolts 75 / 100 / 125 / 150 / 175 / 200 mm
- » 6 pcs. 12 / 14 / 16 mm T-nuts
- » 6 pcs. flanged nuts
- » 4 pcs. coupling nuts
- » 6 pcs. step clamps
- » 6 pcs. step blocks

Description	Clamp Kit SPW 10	Clamp Kit SPW 12	Clamp Kit SPW 14
EAN	4260364293425	4260364293432	4260364293449
Item No.	535 5210	535 5212	535 5214

## PRECISION PARALLELS



### PRECISION PARALLELS 28-PCS. OF HIGH QUALITY STEEL

- » set of 14 pairs in a box
- » made of high quality steel
- » supplied in wooden case
- » dimensions (L x W) 150 x 10
- » dimensions (H) 14 / 16 / 18 / 20 / 22  
24 / 26 / 28 / 30 / 32 / 35 / 40 / 45 / 50 mm
- » fine ground to 0,01 mm accurately
- » for precision work for parallel holding fixture of  
work parts in vices or marking plates

Description	Precision Parallels
EAN	4260364293357
Item No.	535 0028



## COLLET CHUCKS AND COLLETS



### COLLET CHUCK MK

- 15-PCS. IN PLASTIC CASE MT 2
- 15-PCS. IN PLASTIC CASE MT 3
- 15-PCS. IN PLASTIC CASE MT 4

### COLLET CHUCK ISO

- 15-PCS. IN PLASTIC CASE ISO 30
- 15-PCS. IN PLASTIC CASE ISO 40

- » collet chuck
- » hook wrench
- » 15 collets: 3 / 4 / 5 / 6 / 7 / 8 / 9 / 10 / 11 / 12 / 13 / 16 / 18 / 20 / 25 mm

Description	MT 2	MT 3	MT 4	ISO 30	ISO 40
acceptance	MT 2	MT 3	MT 4	ISO 30	ISO 40
dimensions of the case (L x D x H)	350 x 270 x 100 mm	350 x 270 x 100 mm	350 x 270 x 100 mm	350 x 270 x 100 mm	350 x 270 x 100 mm
weight	5 kg	5 kg	5 kg	5 kg	5 kg
<b>EAN</b>	<b>4260364293371</b>	<b>4260364293388</b>	<b>4260364293395</b>	<b>4260364293401</b>	<b>4260364293418</b>
<b>Item No.</b>	<b>535 3502</b>	<b>535 3503</b>	<b>535 3504</b>	<b>535 3530</b>	<b>535 3540</b>

## HSS MILLING CUTTERS



### HSS MILLING CUTTERS 20-PCS. TIN-COATED

- » vapourised titanium applied in reactive gas
- » higher hardness and stability of tool cutters
- » 2 - 5 times longer life
- » double cutting capacity
- » better work piece surface

### CONTENT

- 10 PCS - 2 cutting edges
- » DIN 327 D, short type with 2 cutting edges
- » for milling wedge / drill grooves (fit P9), as well as cutouts from the workpiece center, vertical or lateral milling operations possible with cyl. shank and lateral driving surfaces DIN 1835 B
- » size 3 / 4 / 5 / 6 / 8 / 10 / 12 / 14 / 18 / 20 mm

- 10 pieces - 4 cutting edges
- » DIN 844 B, short type with 4 cutting edges
- » with 30° right spiral; thats why you have a good chip removal
- » front teeth center cutting
- » for normal to solid materials with cyl. shank and lateral driving surfaces DIN 1835 B
- » size 3 / 4 / 5 / 6 / 8 / 10 / 12 / 14 / 18 / 20 mm

Description	HSS Milling Cutters
<b>EAN</b>	<b>4260364293364</b>
<b>Item No.</b>	<b>535 1020</b>

# QUICK CHANGE TOOL MULTIFIX TYPE A / B / C



## QUICK CHANGE TOOL TYP MULTIFIX

- » Multifix "Type A" for metal lathes MD 250, 280, 300
- » Multifix "Type B" for metal lathes MD 360, 420, 460
- » tool holder head and toolholders equipped with profile ground tothing
- » the interchangeable holders are clamped by a pair of clamping shells against the tothing of the central body by means of an eccentric bolt.
- » repeating accuracy 0,01 mm
- » 40 different angular positions
- » angle scale
- » adjust height cutting edge exactly and quickly

All prices without assembly.  
Adjustment and factory assembly at cost.  
(Mounting bolt is not included in the scope of delivery)

## QUICK CHANGE TOOL TYP MULTIFIX

### SCOPE OF DELIVERY

#### TYPE A :

- » 1 pcs. tool holder head "Type A"
- » 3 pcs. tool holders 20 x 90 mm for square tools
- » 1 pcs. tool holder 20 x 90 mm for round tools

#### TYPE B :

- » 1 pcs. tool holder head "Type B"
- » 3 pcs. tool holders 26 x 120 mm for square tools
- » 1 pcs. tool holder 26 x 120 mm for round tools

#### TYPE C :

- » 1 pcs. tool holder head "Type C"
- » 3 pcs. tool holders 32 x 150 mm for square tools
- » 1 pcs. Interchangeable tool holder insert for round chisel

Description	Multifix "Type A"	Multifix "Type B"	Multifix "Type C"
recommended turning diameter	150 - 300 mm	300 - 500 mm	400 - 700 mm
lathe tools	14 - 20 mm	20 - 25 mm	20 - 32 mm
<b>EAN</b>	<b>4260364293494</b>	<b>4260364293500</b>	<b>4260364297058</b>
<b>Item No.</b>	<b>545 2201</b>	<b>545 2202</b>	<b>545 2203</b>

# JAW CHUCK

MANUFACTURER: BISON

## 3-JAW CHUCK

- » 3-jaw chuck with CAMLOCK short taper receptacle, chuck body made of high-quality cast iron with ground working and guide surfaces for permanent clamping and repeat accuracy
- » high concentricity accuracy
- » uniform clamping forces
- » also suitable for workpieces with specific unbalance up to max. 25 mm/kg
- » hand-operated lathe chucks with spiral ring, centrally clamping
- » body made of high-quality cast iron
- » flat spiral ring, drop-forged, balanced and hardened
- » flanks of the spiral plane and jaws are ground
- » high concentricity, better than DIN 6386



### SCOPE OF DELIVERY

- » chuck key
- » hard one-piece internal clamping jaws
- » hard one-piece external clamping jaws

**Additional clamping jaws as well as base and top jaws on request.  
When ordering additional jaws, complete type description of the lathe chuck is required.**

Description 3-jaw chuck	BiS-3 100/3	BiS-3 125/4	BiS-3 160/5	BiS-3 200/5
diameter	100 mm	125 mm	160 mm	200 mm
cone	3	4	5	5
bore	20 mm	32 mm	42 mm	55 mm
chuck width	50 mm	59,5 mm	68 mm	78 mm
weight	2,8 kg	5 kg	9 kg	19 kg
<b>EAN</b>	<b>4260364298970</b>	<b>4260364298987</b>	<b>4260364298994</b>	<b>4260364299007</b>
<b>Item No.</b>	<b>546 1003</b>	<b>546 2254</b>	<b>546 1605</b>	<b>546 2005</b>

Description 3-jaw chuck	BiS-3 200/6	BiS-3 250/6	BiS-3 315/7	BiS-3 315/8
diameter	200 mm	250 mm	315 mm	315 mm
cone	6	6	6	8
bore	55 mm	76 mm	103 mm	103 mm
chuck width	91 mm	103,5 mm	117,7mm	117,7 mm
weight	19 kg	17 kg	21,5 kg	21,5 kg
<b>EAN</b>	<b>4260364299014</b>	<b>4260364299021</b>	<b>4260364299038</b>	<b>4260364299045</b>
<b>Item No.</b>	<b>546 2006</b>	<b>546 2506</b>	<b>546 3157</b>	<b>546 3158</b>

# JAW CHUCK

MANUFACTURER: BISON

## 4 - JAW CHUCK

- » 4-jaw chuck with CAMLOCK short taper receptacle, chuck body made of high-quality cast iron with ground working and guide surfaces for permanent clamping and repeat accuracy
- » high concentricity accuracy
- » uniform clamping forces
- » also suitable for workpieces with specific
- » unbalance up to max. 25 mm/kg
- » hand-operated lathe chucks with spiral ring, centrally clamping
- » body made of high-quality cast iron
- » flat spiral ring, drop-forged, balanced and hardened
- » flanks of the spiral plane and jaws are ground
- » high concentricity, better than DIN 6386



### SCOPE OF DELIVERY

- » chuck key
- » hard one-piece internal clamping jaws
- » hard one-piece external clamping jaws

**Additional clamping jaws as well as base and top jaws on request.  
When ordering additional jaws, complete type description of the lathe chuck is required.**

Description 4-jaw chuck	BiS-4 125/4	BiS-4 160/4	BiS-4 160/5	BiS-4 200/4	BiS-4 200/5
diameter	125 mm	160 mm	160 mm	200 mm	200 mm
cone	4	4	5	4	5
bore	32 mm	42 mm	42 mm	55 mm	55 mm
chuck width	56 mm	81,5 mm	81,5 mm	91 mm	91 mm
weight	5 kg	10 kg	10 kg	13 kg	13 kg
<b>EAN</b>	<b>4260364299052</b>	<b>4260364299069</b>	<b>4260364299076</b>	<b>4260364299083</b>	<b>4260364299090</b>
<b>Item No.</b>	<b>546 1254</b>	<b>546 1604</b>	<b>546 2605</b>	<b>546 2004</b>	<b>546 3005</b>

Description 4-jaw chuck	BiS-4 200/6	BiS-4 250/6	BiS-4 250/8	BiS-4 315/6	BiS-4 400/8
diameter	200 mm	250 mm	250 mm	315 mm	400 mm
cone	6	6	8	6	8
bore	55 mm	76 mm	76 mm	103 mm	136 mm
chuck width	91 mm	103,5 mm	103,5 mm	117,7 mm	128,5 mm
weight	13 kg	17,5 kg	17,5 kg	21,5 kg	27 kg
<b>EAN</b>	<b>4260364299106</b>	<b>4260364299113</b>	<b>4260364299120</b>	<b>4260364299137</b>	<b>4260364299144</b>
<b>Item No.</b>	<b>546 3006</b>	<b>546 3506</b>	<b>546 2508</b>	<b>546 3156</b>	<b>546 4008</b>

# TURNING TOOL 6-PCS. + 7-PCS. HM-TURNING PLATES

## TURNING TOOL / HM-TURNING PLATES



**TURNING TOOL**  
6-PCS. 10 MM / 6-PCS. 12 MM  
CONSISTS OF 6-PCS. CUTTING TOOLS  
10 MM OR 12 MM

- » 2 left roughing tools
- » right roughing tool
- » recessing tool 30°
- » recessing tool 80°
- » lathe tools
- » supplied in a solid box

Description	Turning Tool	Turning Tool
Completion	10 MM	12 MM
EAN	4260364293517	4260364293524
Item No.	545 0210	545 0212



**TURNING TOOLS WITH CUTTING TOOLS FOR INTERNAL AND EXTERNAL**  
6-PCS. 10 MM / 6-PCS. 12 MM

- » 2 boring tools 55° and 60°
- » 2 external tools 55° and 60°
- » inside turning bit
- » right outer turning tool
- » supplied in a solid box

Description	10 mm	12 mm
EAN	4260364293531	4260364293548
Item No.	545 1210	545 1212



**TURNING TOOL HM IN SOLID PLASTIC BOX**

- » suitable for turning plates with HM inserts
- » cutting tool 1 SCLCL
- » cutting tool 2 SCSCR
- » cutting tool 3 SCBCR
- » cutting tool 4 SCKCR
- » cutting tool 5 SCMCN
- » cutting tool 6 SCLCR
- » cutting tool 7 SOØ SCLCR

Description	12 mm	16 mm
EAN	4260364293555	4260364293562
Item No.	545 2212	545 2216



**HM-TURNING PLATES**

- » Suitable for turning steels with carbide inserts of 12 mm or 16 mm

Description	12 mm	16 mm
EAN	4260657651321	4260364293579
Item No.	545 1112	545 1116



# STANDS



## UNIVERSAL STAND

- » suitable stand for milling and drilling machines
- » with centre console
- » disc with cooling liquid drain

Description	Universal Stand (BFM 45)
dimensions (L x D x H)	780 x 580 x 630 mm
weight	22 kg
<b>EAN</b>	<b>4260364293067</b>
<b>Item No.</b>	<b>535 1035</b>



Description	Stand for TD 1803 Vario
dimensions (L x D x H)	840 x 420 x 760 mm
weight	42 kg
<b>EAN</b>	<b>4260364297065</b>
<b>Item No.</b>	<b>546 1180</b>



Description	Stand for BFM 20 Vario / 20 L Vario	Stand for BFM 35 Vario
dimensions (L x D x H)	340 x 420 x 800 mm	375 x 540 x 800 mm
weight	35 kg	37 kg
<b>EAN</b>	<b>4260364293104</b>	<b>4260364293111</b>
<b>Item No.</b>	<b>535 0020</b>	<b>535 0035</b>



Description	Stand for TD 2004 Vario	Stand for TD 2406 Vario	Stand for TD 2506 Vario	Stand for TD 2807 Vario	Stand for TD 3018 Vario
dimensions (L x D x H)	960 x 420 x 760 mm	960 x 420 x 760 mm	1.100 x 420 x 760 mm	1.250 x 440 x 760 mm	1.250 x 460 x 760 mm
weight	48 kg	48 kg	50 kg	52 kg	54 kg
<b>EAN</b>	<b>4260364297515</b>	<b>4260364297522</b>	<b>4260364297539</b>	<b>42603642937546</b>	<b>42603642937553</b>
<b>Item No.</b>	<b>546 0204</b>	<b>546 0246</b>	<b>546 0256</b>	<b>546 0287</b>	<b>545 0318</b>

DRILLING

MILLING

TURNING

SAWING

GRINDING

BENDING

CUTTING / PRESSING

OTHER MACHINES

ACCESSORIES

# MACHINE FEET

SMALL / MEDIUM / LARGE



## MACHINE FEET LEVELLING OSCILLATING ELEMENT

- » oscillating isolated
- » without ankering
- » height adjustable

Description	small	medium	large
diameter	80 mm	120 mm	160 mm
height	30 mm	30 mm	40 mm
threading	M10	M12	M16
weight	0,3 kg	1 kg	2 kg
<b>EAN</b>	<b>4260364293036</b>	<b>4260364293043</b>	<b>4260364293050</b>
<b>Item No.</b>	<b>545 2501</b>	<b>545 2502</b>	<b>545 2503</b>

# RB 290 / RB 1.100 / RBV 450 / RBV 2.250 / RBV 4.500

ROLLER STANDS WITH INFINITELY VARIABLE HEIGHT  
ADJUSTMENT



PIC: RB 290

PIC: RB 1.100

Description	RB 290	RB 1.100
height of stand	575 - 900 mm	620 - 1.000 mm
width of rollers	290 mm	350 mm
max. load	150 kg	300 kg
weight	6 kg	23 kg
<b>EAN</b>	<b>4260364292954</b>	<b>4260364292961</b>
<b>Item No.</b>	<b>530 1115</b>	<b>530 1100</b>



PIC: RBV 450

Description	RBV 450	RBV 2.250	RBV 4.500
height of stand	652 - 857 mm	712 - 917 mm	887 - 1.092 mm
workpiece Ø	50 - 910 mm	50 - 910 mm	260 - 1.210 mm
width of rollers	203 x 65 mm	203 x 65 mm	305 x 100
max. load	450 kg	2.250 kg	4.500 kg
weight	55 kg	65 kg	250 kg
<b>EAN</b>	<b>4260657651291</b>	<b>4260657651307</b>	<b>4260657651314</b>
<b>Item No.</b>	<b>530 0450</b>	<b>530 2250</b>	<b>530 4500</b>

# MR 4 / MR 7 / E-MAS-MODELS

## ROLLER STANDS / STOP- AND MEASURING SYSTEM



### ROLLER STAND

Height adjustable material pedestal for material depot and material feeding of work parts at metal saws.

- » handling system for plating of long and heavy work parts
- » applicable for metal band saws, circular saw benches etc.
- » roller stand with stepless height adjustment and arrest
- » safe and heavy - duty workpiece support via robust, pressure resistant steel reel
- » massive construction made of multiple edged special profile
- » interminable prolongable

Description	MR 4	MR 7
carrying roller diameter	60 mm	60 mm
carrying roller width	360 mm	360 mm
load	500 kg	700 kg
height adjustment	650 - 950 mm	650 - 950 mm
dimensions (L x D x H)	1.000 x 440 x 650 - 950 mm	2.000 x 440 x 650 - 950 mm
weight	30 kg	58 kg
<b>EAN</b>	<b>4260364292978</b>	<b>4260364292985</b>
<b>Item No.</b>	<b>231 2004</b>	<b>231 2007</b>

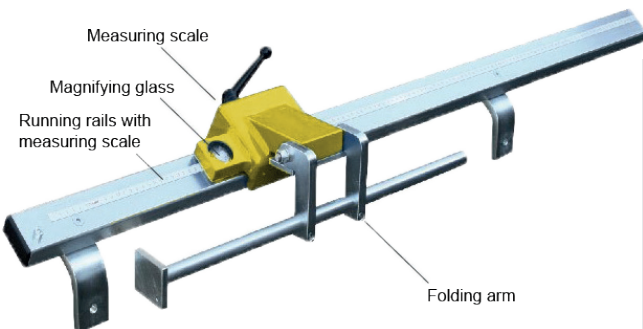

Our stop and measuring system serves as a simple supplement to a wide range of roller conveyors.

The system consists of a very stable running rail (60 x 30 x 3 mm), which is screwed to a roller conveyor of suitable length. Mounting brackets are included in the scope of delivery.

The rail is connected to an easy-running, ball-bearing mounted measuring carriage, which is also equipped with a ball-bearing mounted folding arm. The complete system is extremely robust and designed for a long service life in rough workshop conditions.

Description	E-MAS 2.000	E-MAS 3.000	E-MAS 4.000	E-MAS 5.700
rail	2.280 mm	3.280 mm	4.280 mm	6.000 mm
fixing brackets	3	4	5	7
measuring length	2.000 mm	3.000 mm	4.000 mm	5.700 mm
<b>EAN</b>	<b>4260364297812</b>	<b>4260364297829</b>	<b>4260364297836</b>	<b>4260364297843</b>
<b>Item No.</b>	<b>531 0080</b>	<b>531 0120</b>	<b>531 0160</b>	<b>531 0240</b>

Self-sealing magnetic tape measure with scanning head and 1-axis digital readout system is optionally available instead of steel tape measure and reading optics.

## UR 1.000 / UR 2.000 / UR 3.000

### ROLLER STAND



- » steel castors with ball bearings
- » sturdy construction made of special profile
- » versatile use
- » very robust
- » roller conveyors infinitely height-adjustable and clampable
- » easy material transport for feeding and removing workpieces
- » universally applicable for metal band saws and circular saws
- » auxiliary support for long workpieces
- » roller conveyors with stop are equipped with a millimetre scale
- » stop with digital display on request

**IN** = material feed, **OUT** = remove sawn off material

PIC: TOP: OUT, BOTTOM: IN

Description	UR 1.000 IN / OUT	UR 2.000 IN / OUT	UR 3.000 IN / OUT
support roller diameter	60 mm	60 mm	60 mm
support roller width	360 mm	360 mm	360 mm
static table load	600 kg	1.200 kg	1.800 kg
height adjustability	620 - 1.050 mm	620 - 1.050 mm	620 - 1.050 mm
dimensions (L x D x H)	1.000 x 450 x 620 - 1.030 mm	2.000 x 450 x 620 - 1.030 mm	3.000 x 450 x 620 - 1.030 mm
weight	26,2 kg	60,5 kg	84,5 kg
<b>EAN</b>	<b>4260364297072 / 4260657651949</b>	<b>4260364297089 / 4260657651956</b>	<b>4260364297096 / 4260657651963</b>
<b>Item No.</b>	<b>531 0004 / 531 1004</b>	<b>531 0007 / 531 1007</b>	<b>531 0012 / 531 1012</b>

## E-AR 3.000

### ROLLER CONVEYORS WITH DRIVE AND MEASURING

**NEW**

**PREMIUM-LINE**



Description	E-AR 3.000
dimensions (L x D x H)	3.719 x 885 x 1.670 mm
weight	370 kg
<b>EAN</b>	<b>4260364298468</b>
<b>Item No.</b>	<b>531 0030</b>

#### E-AR 3.000

Automatic roller conveyor with servo drive, integrated length measuring system and automatic positioning. Feed path and number of steps programmable. Control via touch screen with colour display.

# UNIVERSAL COOLING DEVICE



## UNIVERSAL COOLANT DEVICE BACKFITTING PUMP FOR SELF-INSTALLATION

- » pump with tank
- » flexible coolant hose made of plastic
- » cut off cock
- » assembly small components

Description	Coolant Device	Coolant Device
tank capacity	10 l	10 l
pumping capacity	12 l/min	12 l/min
voltage	230 V / 50 Hz	400 V / 50 Hz
dimensions (L x D x H)	360 x 250 x 300 mm	360 x 250 x 300 mm
weight	7 kg	7 kg
<b>EAN</b>	<b>4260364294194</b>	<b>4260364292992</b>
<b>Item No.</b>	<b>535 3023</b>	<b>535 3040</b>

# MICRO SPRAYING DEVICE



## MICRO SPRAYING DEVICE BACKFITTING SET FOR SELF-INSTALLATION on sawing machines of various designs

- » container for minimum quantity lubricant
- » mixture regulation unit
- » pressure indicator and regulating valve
- » compressed air connection 6 mm
- » sturdy plastic hoses
- » adjustable spray valve (optional double spray nozzle)

PIC: WITH OPTIONAL  
DOUBLE SPRAY NOZZLE

Designation	Micro Spraying Device
spray power	0 - 100 ml/h
air connection	3 - 7 bar
power connection	230 Volt / 50 Hz
weight	3 kg
<b>EAN</b>	<b>4260364297102</b>
<b>Item No.</b>	<b>535 3050</b>



## COOLING LIQUID



**COOLANT EMULSION**  
5 / 20 LITER ORGANICALLY DEGRADABLE

- » protects against rust
- » organically degradable
- » ratio of mixture 1:20
- » tank content yields 100 l of coolant emulsion

Description	Coolant emulsion	Coolant emulsion
case content	5 ltr	20 ltr
dimensions (L x D x H)	180 x 140 x 250 mm	approx. 290 x 259 x 386 mm
weight	5 kg	20 kg
<b>EAN</b>	<b>4260364293005</b>	<b>4260364291094</b>
<b>Item No.</b>	<b>580 1030</b>	<b>580 1031</b>

## COOLANT CONCENTRATE



**COOLANT CONCENTRATE**

Chlorine-free, especially for use in minimum quantity lubrication systems in conjunction with compressed air.

Description	Coolant concentrate	Coolant concentrate
case content	0,5 ltr	5 ltr
dimensions (L x D x H)	80 x 40 x 120 mm	180 x 140 x 250 mm
weight	0,6 kg	5,5 kg
<b>EAN</b>	<b>4260657651826</b>	<b>4260657651833</b>
<b>Item No.</b>	<b>580 1005</b>	<b>580 1050</b>

## GEARBOX OIL AR 150



**GEARBOX OIL AR 150**

- » universal industrial gear oil
- » produced by high-quality base oils and modern sulphur-phosphor-additives
- » protects against rust even in contact with salt water
- » wear protection in the toughest conditions

Description	Gearbox oil AR 150
case content	5 ltr
dimensions (L x D x H)	180 x 140 x 250 mm
weight	5 kg
<b>EAN</b>	<b>4260364297119</b>
<b>Item No.</b>	<b>580 1150</b>

DIN 51517	Flashpoint 246 °C
CLP 150	Pourpoint -24 °C
Kin. Viscosity 40°C, 155 m/s	Viscosity index 94

# SAW BLADES FOR METAL CIRCULAR SAWS

## GRINDING BELTS FOR BSM

### SAW BLADES / GRINDING BELTS



#### SAW BLADES FOR KKS

	Description	EAN	Item No.
	HSS saw blade, Standard 315 x 2, 5 x 40 mm 200 Hz	4260364293586	530 0315
	HSS/ DMo5 saw blade, steam treatment, Standard 315 x 2,5 x 40 mm 200 Hz	4260364293593	530 0320
	HSS/ E - saw blade, steam treatment, Standard 315 x 2,5 x 40 mm 200 Hz	4260364293609	530 0325
	HSS/ DMo5 - saw blade, steam treatment, Standard 315 x 3,0 x 40 mm 200 Hz	4260364293616	530 0330
	HSS/ E - saw blade, steam treatment, Standard 315 x 3, 0 x 40 mm 200 Hz	4260364293623	530 0335

#### GRINDING BELTS FOR BSM MINIMUM PURCHASE 5 PCS.

	Description	EAN	Item No.
	<b>grinding belt for TBSM 100-2</b>		
	dim.: 100 x 1.220 mm K 40	4260364299717	525 1240
	dim.: 100 x 1.220 mm K 80	4260364299724	525 1280
	<b>grinding belt for BSM 75</b>		
	dim.: 75 x 2.000 mm K 40	4260364293708	525 1040
	dim.: 75 x 2.000 mm K 60	4260364293692	525 1060
	dim.: 75 x 2.000 mm K 80	4260364293685	525 1080
	dim.: 75 x 2.000 mm K 100	4260364293678	525 1100
	dim.: 75 x 2.000 mm K 120	4260657651338	525 1120
	<b>grinding belt for BSM 150</b>		
	dim.: 150 x 2.000 mm K 40	4260364293661	525 2040
	dim.: 150 x 2.000 mm K 60	4260364293654	525 2060
	dim.: 150 x 2.000 mm K 80	4260364293647	525 2080
	dim.: 150 x 2.000 mm K 100	4260364293630	525 2100
	dim.: 150 x 2.000 mm K 120	4260657651345	525 2120
	<b>grinding belt for BSM 220</b>		
	dim.: 220 x 2.000 mm K 40	4260657651352	525 3040
	dim.: 220 x 2.000 mm K 60	4260657651369	525 3060
	dim.: 220 x 2.000 mm K 80	4260657651376	525 3080
	dim.: 220 x 2.000 mm K 100	4260364299878	525 3100
	dim.: 220 x 2.000 mm K 120	4260657651383	525 3120
	<b>grinding belt for KRBS 100 and RPSM</b>		
	dim.: 100 x 2.000 mm K 40	4260364293746	525 5040
	dim.: 100 x 2.000 mm K 60	4260364293739	525 5060
	dim.: 100 x 2.000 mm K 80	4260364293722	525 5080
	dim.: 100 x 2.000 mm K 100	4260364293715	525 5100
	dim.: 100 x 2.000 mm K 120	4260657651390	525 5120

#### PROMOTION ITEMS

	Description	EM-Cap	EM-Clock
	EAN	4260364293753	4260364293760
	Item No.	999 1001	999 1002

DRILLING

MILLING

TURNING

SAWING

GRINDING

BENDING

CUTTING /  
PRESSING

OTHER  
MACHINES

ACCESSORIES

# DIGITAL MEASURING SYSTEM

PROFESSIONAL EQUIPMENT FOR INDUSTRIAL USE AT SMALL PRICE

**PREMIUM-LINE**



PIC: MONITOR WITH LED DISPLAY

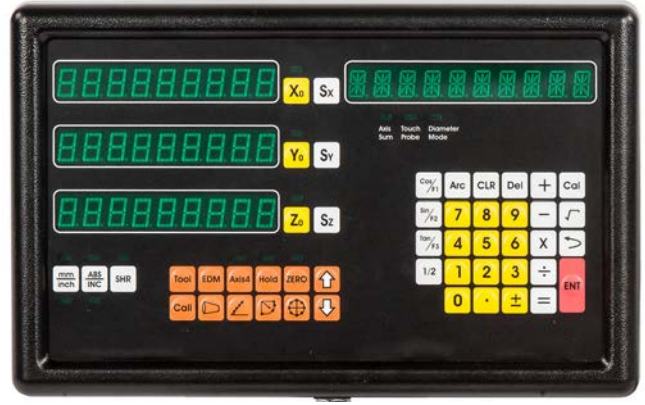

PIC: STANDARD MONITOR (3-AXIS)

With the high-quality digital PREMIUM-LINE measuring system, the handling of conventional machine tools becomes faster, safer and significantly easier.

The digital PREMIUM-LINE measuring systems are applicable for milling machines, lathes, drilling machines, machines for sheet metal workings, special machines etc. and are well suited for all machines equipped with straight-line movements and wherever straight-line movements have to be measured, e.g. feed devices.

**New model with LCD color display, for 2 - 4 measuring rulers, including angle measurement, 7 languages possible: German, English, French, Dutch, Spanish, Portuguese and Turkish**

Description	EAN	Item No.
indicator for one axis	4260364295658	610 0001
indicator for one axis without keyboard	4260364299731	610 1001
indicator for two axis	4260364295474	610 0002
indicator for three or 2 + 1 (e.g. Turning machine) axis	4260364295481	610 0003
indicator for four or 3 + 1 (e.g. Drilling machine) axis	4260364295498	610 0004
<b>EM PREMIUM-LINE for 1-4-axis</b>	4260364297126	611 0001

**Easy to install magnetic measuring tapes on aluminum strip in different measuring lengths with 3.5 m metal covered cable to display device incl. assembled connector.**

Description	EAN	Item No.
aluminium moulding incl. magnetic tape and reading head 500 mm	4260364297249	610 3050
aluminium moulding incl. magnetic tape and reading head 1.000 mm	4260364297256	610 3100
aluminium moulding incl. magnetic tape and reading head 2.000 mm	4260364297263	610 3200

# LINEAR MEASURING SYSTEM

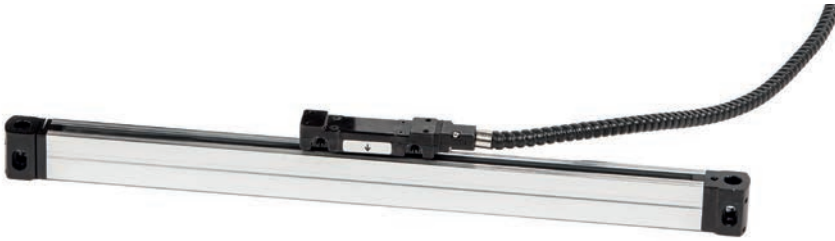

**PREMIUM-LINE**

PIC: CAPSULED MEASURING ROD WITH CONNECTION CABLE, PLUG AND METAL SPIRAL SHEATHING

Open low-cost systems for simple applications on request.

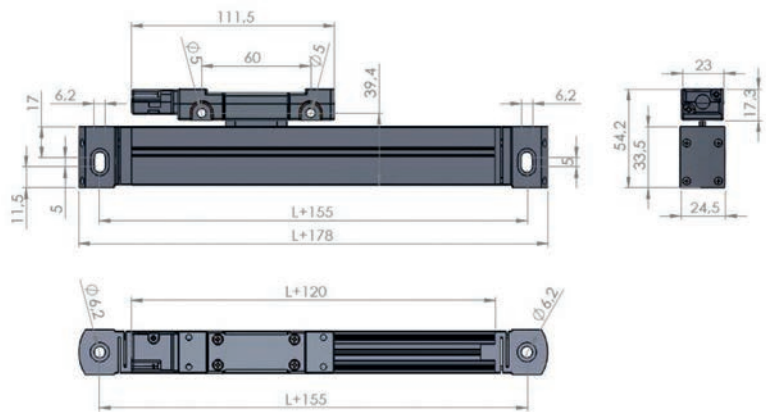

Rulers	EAN	Item No.
EM ruler 100 mm	4260364297164	610 1010
EM ruler 150 mm	4260364297171	610 1015
EM ruler 200 mm	4260364297188	610 1020
EM ruler 250 mm	4260364297195	610 1025
EM ruler 300 mm	4260364297201	610 1030
EM ruler 400 mm	4260364295511	610 1040
EM ruler 500 mm	4260364295528	610 1050
EM ruler 600 mm	4260364295535	610 1060
EM ruler 700 mm	4260364295542	610 1070
EM ruler 800 mm	4260364295559	610 1080
EM ruler 900 mm	4260364295566	610 1090
EM ruler 1.000 mm	4260364295573	610 1100
EM ruler 1.200 mm	4260364295580	610 1120
EM ruler 1.350 mm	4260364295597	610 1135
EM ruler 1.500 mm	4260364295603	610 1150
EM ruler 1.750 mm	4260364295610	610 1175
EM ruler 2.000 mm	4260364295627	610 1200
EM ruler 2.500 mm	4260364295634	610 1250
EM ruler 3.000 mm	4260364295641	610 1300

We recommend capsuled mini measuring rods for narrow installation possibilities or small machines.

Description	EAN	Item No.
EM Mini-ruler 50 mm	4260364297133	610 2005
EM Mini-ruler 100 mm	4260364297140	610 2010
EM Mini-ruler 150 mm	4260364297157	610 2015

Our measuring rods are always supplied with the connection cable fitted.

DRILLING

MILLING

TURNING

SAWING

GRINDING

BENDING

CUTTING / PRESSING

OTHER MACHINES

ACCESSORIES

## LEASING - QUITE SIMPLE



Special Sale / Leasing

**Already from € 2.000,- Epple Maschinen® can be financed by leasing.**

Advantages of leasing:

- **Liquidity**  
You preserve your equity capital, your liquid funds and the credit line at your housebank. In contrast to the purchase, leasing does not lead to an immediate debit of liquidity at the time of investment.
- **Fixed constant costs**  
The leasing down payments are fixed and therefore offer you a secure calculation basis.
- **Cost expenditure**  
Leasing fulfils the "pay-as-you-earn" condition; if the machine is used appropriately, it pays for itself through monthly income.
- **Balancing**  
Leasing is balance sheet neutral, i.e. your balance sheet ratios do not change.
- **Taxes**  
There are no investment-related taxes.
- **Utilisation**  
You have unrestricted right to use the machine. Warranty services remain fully valid.

**Your personal leasing offer is available on request.**



# SPECIAL SALE

2ND CHOICE MACHINES, MACHINES WITH TRANSPORT DAMAGES,  
SAMPLE MACHINES, USED MACHINES

In our special sale you will find machines as good as new which are not listed in the catalogue, e.g. sample machines from exhibitions and trade fairs. In addition, 2nd choice machines, machines with transport damage, sample machines, second-hand machines and the like.

The machines of the special sale are checked for their function in exactly the same way as regular catalogue goods. Overhauls of purely optical points are not provided for, but are taken into account in the price reduction.

Due to additions and disposals, the stock of the special sale changes almost daily. If you are interested, we recommend that you to inquire about the current status.

Visit our special sale on our homepage under: <http://www.epple.com/aktionen/sonderverkauf.html>

Deutsch

AGB Kontakt Impressum Datenschutz

**Epple**<sup>®</sup>  
Maschinen

Startseite

Produkte

News

Aktionen

Messen

Download

Unternehmen

Kontakt

Schnellsuche

## Sonderverkauf

Als Sonderverkauf bieten wir 2.Wahl-Maschinen, Maschinen mit Transportschäden, Mustermaschinen, Gebrauchtmaschinen und dgl.

Alle Maschinen werden selbstverständlich in unserer Servicewerkstatt gewartet und geprüft.

Bei Interesse setzen Sie sich bitte direkt mit uns in Verbindung:

E-Mail: [info@epple.com](mailto:info@epple.com)  
Telefon <+49> 07335 9243 - 0



### General note

With the publication of this catalogue, all previous catalogues and price lists become invalid. All listed prices are subject to change and non-binding. The prices do not include packaging costs (1% of the net value of the goods), transport, unloading, assembly and, if applicable, instruction costs, as well as the statutory VAT. We reserve the right to make technical changes in the course of further development and optical product changes. The illustrations of the machines are partly with optional accessories. All prices stated are calculated at the time of printing of the catalogue. In the event of a change in the overall economic situation, e.g. due to a higher inflation rate, offer and sales prices may deviate from the catalogue price. In such cases, the catalogue prices would then be revoked. No liability is accepted for printing errors, mistakes, incorrect presentation or faulty technical specifications. For transport reasons, some machines and equipment are delivered partially dismantled and without oil filling. Auxiliary materials and operating supplies such as lubricants, hydraulic fluids and coolants are not included in the scope of delivery of the machines. Our machines are sold through specialist dealers. Delivery is exclusively subject to our terms of delivery and payment. Our General Terms and Conditions of Business apply, which can be viewed at [www.epple.com](http://www.epple.com) / under the heading "General Terms and Conditions of Business" or will be sent to you on request. The goods remain our property until full payment has been made. In the event of resale to third parties, our retention of title shall remain in force until the goods have been paid for in full. In the commercial sector, the statutory warranty provisions apply. This catalogue is subject to copyright; reproduction and reprinting, in any form or by any means, including excerpts, require our written permission. To protect our products, we register trademark, patent and design rights, insofar as this is possible in individual cases.

You will find information on the precision of the products in the technical data on the catalogue pages. If no values can be found here, please contact us. The stated accuracies are achieved under standard conditions (proper installation of the machines and ambient temperatures of 20°C). Machines that are not titled PREMIUM or HIGHLINE are assigned to the standard programme. Machines in the standard programme are not designed for continuous operation, as they are subject to a special price/performance level. All machines may only be operated by suitable and instructed personnel.

Electrically operated machines must be connected by an electrician or a qualified electrician. Machines with frequency converters or inverters should not be operated via connection plugs, but should be connected directly to the mains supply of the building's electrical system. If earth leakage circuit breakers are present in the building's electrical system, all-current sensitive earth leakage circuit breakers type B are recommended. AC-sensitive earth leakage circuit breakers of type AC (AC only) are unsuitable for frequency converters.

# PRODUCT MOVIES



Epple Maschinen



**EppleMaschinen**  
 325 Abonnenten
 **ABONNIEREN**

[ÜBERSICHT](#)
[VIDEOS](#)
[PLAYLISTS](#)
[KANÄLE](#)
[DISKUSSION](#)
[KANALINFO](#)
🔍

Discover our product movies

on our YouTube channel at:  
<https://www.youtube.com/user/EppleMaschinen>

on our homepage under:  
<http://www.epple.com/unternehmen/produktvideos.html>



Deutsch AGB Kontakt Impressum Datenschutz

**Epple**  
Maschinen

[Startseite](#)
[Produkte](#)
[News](#)
[Aktionen](#)
[Messen](#)
[Download](#)
[Unternehmen](#)
[Kontakt](#)

**Produktvideos**



Epple Maschinen Blech...



Epple Maschinen Rund...



Epple Maschinen Alum...



Epple Maschinen Tren...



Epple Maschinen Säul...



Epple Maschinen Mag...  
selbstständiges Lösen der Biegeschiene  
independent release of the bending machine



Epple Maschinen Meta...

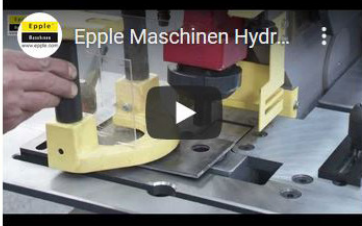

Epple Maschinen Hydr...



Epple Maschinen Abka...

# INDEX

<b>Accessories</b>	289 - 315	<b>Life Center</b>	300
Aluminum Circular Saw	134 - 136	Linear Measuring Systems	315
Angle Bender	152		
Angle Machine Vice	287	<b>Machine Feet</b>	308
Arbor Presses	236	Magnetic Bending Machines	180
Automatic Circular Saw	133	Magnetic Clamping Plates	297
		Mandrel Bending Machines	157 - 161
<b>Band Grinding Machines</b>	144	Metal Band Saw	75 - 127
Band Saws	75 - 127	Metal Belt Grinder	142 - 143
Bed-Type Milling Machines	55 - 56	Metal Circular Saw	129
Bending Machines	171 - 180	Micro Spraying Device	311
Bending Machines with Motor	176 - 177	Milling Machines	33 - 56
Bending Machine with Hydr. Support	178 - 179	Milling Vices	293 - 294
		Morse Tapers	300
<b>Circular Saw</b>	128 - 132	Morse Taper Drill Case	298
Circular Shear	233 - 234	Multifix	303
Clamp Kit	301		
Cold Circular Saw	128 - 132	<b>Notching Machines</b>	230 - 232
Collet Chucks	302		
Column Drilling Machine	17 - 21	Plasma Cutting System	250 - 251
Coolant Device	311	Pneumatic Rebate Pressing Machine	169
Coolant Liquid	312	Precision Parallels	301
Cross Tables	296	Precision Geared Lathe Machines	62 - 63
Cutting Machine	137	Press Brake	282 - 284
		Profile Roller Machines	210 - 228
<b>Deburring Machines</b>	162 - 167		
Digital Readout System	314	<b>Quick Action Drill Chuck</b>	298
Drill Set	298	Quick Change Tool	303
Drilling Machines	15 - 29		
Drilling-Milling Machines	36 - 43	<b>Radial Drilling Machine</b>	32
Double Belt Grinders	150	Reducing Sleeves	300
Double Ended Grinders	140	Roller-Round-Bending Machines	181 - 209
		Roller Stands	309 - 310
<b>Extension Sleeves</b>	300	Rotary Tables	296
<b>Flanging Machine</b>	170	<b>Saw Bands</b>	124 - 127
Flat and Surface Grinding Machine	149	Saw Blades	126 - 127
Flow Hole Moulding Process	299	Sleeves	300
Folding Machines	168	Stands	307
Four-Roller-Round-Bending Machines	198 - 209	Surface Grinding Machines	148
<b>Geared Drilling Machine</b>	22 - 29	<b>Table Drilling Machine</b>	16 / 18 - 19
Geared Drilling-Milling Machines	36 - 41	Threading Attachements	298
Grinding Equipment	313	Threading Machine	30 - 31
Grinding Machines	144 - 150	Three-Roller-Round-Bending Machine	182 - 197
Grinding Machine with Frequency Converter	141	Tube Grinder	145 - 146
Guillotine Shears	238 - 242	Turning Plates	306
		Turning Tools	306
<b>Hand Lever Shears</b>	234		
Heavy Duty Center Lathe Machines	66 - 74	<b>Universal Milling Machine</b>	48 - 53
HM-Turning Plates	306	Universal Precision Lathe Machines	64 - 65
HSS-Milling Cutters	302		
Hydraulic Bending Press	264 - 265	<b>Vertical Band Saw</b>	138
Hydraulic Hole Punching Machine	260 - 261	Vices	290 - 295
Hydraulic Pipe Bending Machine	154		
Hydraulic Press	268 - 269	<b>Welding Positioner</b>	286
Hydraulic Steel Workers	254 - 259	Working Light	295
Hydraulic Workshop Press	272 - 276	Workshop Presses	270 - 276
<b>Jaw Chucks</b>	304 - 305		
<b>Laser Cutting System</b>	252 - 253		
Lathe Machines	58 - 74		
Leasing	316		
Lever Shears	234 - 237		

# MACHINES FOR CRAFTSMEN AND INDUSTRY

## METAL AND SHEET METAL WORKING MACHINES



## LEASING QUITE SIMPLE

Starting at 2.000,- EUR, Epple Machines® can be financed by leasing.  
Your personal leasing offer is available on request.



YOUR RELIABLE PARTNER SINCE 45 YEARS

EPPLE MASCHINEN®

**Epple Maschinen GmbH**

Auf der Breite 2-14

D - 73349 Wiesensteig

Phone: <+49> 07335 - 9243 - 0

Fax: <+49> 07335 - 9243 - 300

Email: info@epple.com

**www.epple.com**